

STANDARD SPECIFICATIONS

(Based on Model CH613 6x4 Tractor)

Canadian orders require Engine Block Heaters.

ENGINE: MACK, AC-310/330 ASET

Horsepower, 310 HP [231 kW] at 1800 Gov. RPM
Peak Horsepower, 330 HP [246 kW] at 1500 RPM
Max. Torque, 1360 lb/ft [1 844 N•m] at 1100 RPM
V-MAC III—Total Vehicle Electronics
Lube Oil System, Full Flow ESI +
Centri-Max® Ultra
Centrifugal Oil Filter
Flywheel Housing, Aluminum
Silicone Hoses and Tubing on Engine
Air Compressor, Chassis Mounted 18.7 cfm min. rtg. w/
Air Governor
Starting System
Starter, 12-Volt 39MT Type 500
Batteries, (3) Mack 12-Volt M/F Type, 660 CCA
Total 1980 CCA with Kalas Cables
Alternator, 12V 100A, Delco (24 SI)
Air Intake System
Air Cleaner, 11" [279 mm] Single Element
Dry Type, Under Hood
Air Intake from Both Sides of Hood
Air Restriction Monitor, Grad. Lock Up Type (Air Intake Mtd.)
Exhaust, Vertical w/Muffler Heat Shield
Cooling System—Shutterless Type
Aluminum Radiator
Anti-Freeze to -10°F [-23°C]
Fan Drive, Electronically Modulated Type
w/Lightweight Plastic Fan
Poly-V Fan Belt w/Automatic Tensioner
Coolant Recovery Tank—6 Quart [5.7L]
PowerLeash Engine Brake

CLUTCH: EATON FULLER, CL798

15.5" [394 mm] Ceramic Dampened Disc, 2-Plate, Coaxial Spring

TRANSMISSION: FULLER, FRO-13210C

10-Speed, Ratios: 12.69 Low—0.74 High
Driveline: Meritor 176N and 17N HD Interaxle w/Coated Splines

CAB: CONVENTIONAL, CA65

Interior Features:

Basic: Select Trim Level; Color: Select Pewter Gray
Ash Tray
Cigar Lighter
CB—5-way Binding Post
Coat Hook
Dispatch Box
Overhead Console
Radio Accommodations
Air Conditioner w/Integral Heater with R134a Refrigerant
Dome Light w/Self-Contained Switch, "On" when Driver or
Rider Side Door is Open
Door Mounted Courtesy Lamp, "On" when Driver or
Rider Side Door is Open
Steering Wheel, 18" Dia. 2-Spoke Soft Feel
Tilt & Telescope—Steering Column

Seats:

Driver's, Bostrom Talladegha 915 (Mid-Back)
Rider's, MACK Non-Suspension (Mid-Back)
Seat Belts—Driver's and Rider's
Lap & Shoulder w/Seat Belt Retractor & "Komfort Latch"
Sun Visor—Left Side
Floor Mats, Rubber w/Closed Cell Vinyl Nitrile Backing

MACK

CXN603

SERIES

CHASSIS



- Conventional Chassis
- Set-Back Front Axle
- 6-Wheel Tractor
- ABS (Anti-Lock Brake System)

The MACK CXN603 is for fleet owner and owner-operator alike, a total chassis optimized through computer-aided design for an excellent strength-to-weight ratio. The cab incorporates exceptional room and comfort with the highest standards of fit and finish. The cab ride is an innovative cab air suspension, providing unsurpassed smoothness and comfort. The axle-back configuration contributes to handling ease, while the quiet roomy interior caters to the driver's every need.

STANDARD

ENGINE: MACK AC-310/330 ASET
330 HP [246 kW] Peak Horsepower

TRANSMISSION: FULLER, FRO-13210C
10-Speed

FRONT AXLE: MACK FXL12
12,000 lb. [5 443 kg] Capacity

REAR AXLE: MERITOR RT40-145
40,000 lb. [18 144 kg] Capacity



STANDARD SPECIFICATIONS

(Continued)

CAB: continued

Interior Features: Operational:

T.M.C. Recommended Instrument Panel
Air Pressure Gauge
Voltmeter
Fuel Level Gauge
Engine Oil Pressure Gauge
Engine Coolant Temperature Gauge
Low Air Pressure Indicator (Light and Buzzer)
Speedometer/Trip Odometer, Electronic
Tachometer w/Hourmeter, Electronic
High Beam Indicator
Parking Brake On Indicator
Key Type Starting
Hand Throttle Control
Engine Shutoff, Key-Type Control
Courtesy Light Switch (Head & Clearance)
Directional Signal Switch

Exterior Features:

Welded Steel Shell, Galvanized
MACK Rust Preventative Procedures
Safety Glass Windows
Tinted Windshields, Side and Rear Windows
Conspicuity Treatment, Back of Cab
Windshield Wipers—Dual Actuated Arms, Cowl Mtd.
Wiper Motor Two Speed Electric with Intermittent Feature
Windshield Washers, Electric, Wiper Arm Mtd. with Reservoir Mounted Under Hood
Mirrors, West Coast Type Aero Mirrors
Headlamps—Flush Mounted Halogen—Single Rectangular w/Lexan Lens (Replaceable Bulb) Bezel—Bright Finish (molded plastic)
Daytime Running Lights
Identification and Clearance Lamps (5)
Side Markers—Lamps and Reflectors
Front Integral Turn Signals with Fender
Transistorized Flasher
Horns, (1) MACK Rectangular Single Trumpet Air Horn, Electric, (Single Tone)
Doors—Galvanized Steel with:
Visibility Door with Roll-Up Tinted Windows
Grab Handles (Slip Resistant), RH & LH Behind Door
Cab Mounting:
Two Mounting Brackets at Front
Air Isolation at Rear

HOOD & FENDERS: FIBERGLASS

SMC (Sheet Molding Compound)
Fiberglass with Wheel Splash Aprons
Tilts Forward 75° with Spring Assist
Grille—Hood Mounted Bright Finish Bars with Bright Finish Surround

FRAME:

WB—Wheelbase—156" [3 960 mm]
LP—Load Platform— 151" [3 827 mm]
CA—Cab to Axle—94.4" [2 397]
AF—C/L Axles to End of Frame—56" [1 430 mm]
Frame Rails—Steel
Cross Section—10.47" x 3.54" x .24" [266 x 90 x 6 mm]
Section Modulus—11.52 in.³ [189 cm³]
RBM (per rail) —1,390,000 lb. in. [158 000 N•m]
Tapered and Flanged—28° Rail Ends
Bumper: Non-Metallic Flexible Flush Mounting
BBC—Bumper to Back of Cab—112.6" [2 860 mm]
Towing: Clevis (2)
Fifth Wheel: Fontaine SL3ASB Series Air Slide

FUEL TANKS:

Aluminum, 26" [640 mm] Dia.
Capacity/Location, 72 gal [360 L] LH & RH

FRONT AXLE: MACK FXL12

Set Back Front Axle
12,000 lb [5 443 kg] Capacity
Brakes, "S" Cam 15" x 4" [381 x 102 mm]
Meritor "Q-Plus" Brakes w/o Dust Shields
Slack Adjusters—Automatic
Suspension, MACK Taperleaf Spring (2 Leaf) with 12,000 lb [5 443 kg] Ground Load Rating
Shock Absorbers
Integral Power Steering
Wheel Equipment, 22.5" x 8.25" 10 Hole Hub Piloted Aluminum Disc Wheels
Wheel Seals—Oil
Tires: 295/75R22.5 (singles)

REAR AXLE: MERITOR RT40-145

40,000 lb [18 144 kg] Capacity Axle
Carrier—Malleable
Suspension—Mack 40,000 lb [18 144 kg] Capacity MaxLite 40 EZ (40,000 lb. [18 144 kg]) with Height Control Kit and Malleable Spring Hangers
52" [1 321 mm] Axle Wheelbase
Oil Seals—Stemco Voyager
Brakes—"S" Cam 16.5" x 7" [419 x 178 mm]
Meritor "Q-Plus" Brakes w/o Dust Shields
Slack Adjusters—Automatic
Aux. Spring Brake Chambers, 30/30 Double Diaphragm Type, Mechanical Spring Release; 2 Units
Wheel Equipment, 22.5" x 8.25" 10 Hole Hub Piloted Aluminum Disc Wheels
Wheel Seals—Oil
Tires: 295/75R22.5 (duals)

AIR/BRAKE:

ABS (Anti-Lock Brake System)
Dual Air Brake System
Air Reservoirs—
Two Steel, Horizontal Mtd. on RH Rail Forward of Fuel Tank, Primary—Single Compartment Tank, Supply/
Secondary—Two Compartment
Capacity—5,600 in³ [92 L]
Air Dryer—Heated
Semi-Trailer Connection Package
Air Brake Grouping
Chassis Mtd. Pogo Stick
12-ft Air Hose (2)
Glad Hand (2)
Glad Hand Storage Bracket
(B.O.C.—LH Ground Reachable)
Breakaway Safety Valve
Hand Control Valve for Trailer Brakes
Electric Grouping
12-ft (7-Wire) Cord
7-Wire Plugs

ELECTRICAL:

Steel Battery Box with Molded Plastic Cover Mtd. Forward of LH Fuel Tank
Chassis Electrical
Negative Ground
12-Volt Electrical Circuits and Bulbs
Fuse Protected Circuits
Breaker Protected Headlamp & Windshield Wiper Circuits
Rear Lighting, (2) Combination Stop, Tail Directional & Back-up Lights
Trailer Electrical Package for Doubles Operation

PAINT:

Cab, Hood and Fenders
Color: MACK White, High Gloss Urethane
Chassis Running Gear
Color: MACK Black (Urethane)

WEIGHT:

Front: 8,109
Rear: 6,009
TOTAL: 14,118

CHASSIS SPECIFICATIONS

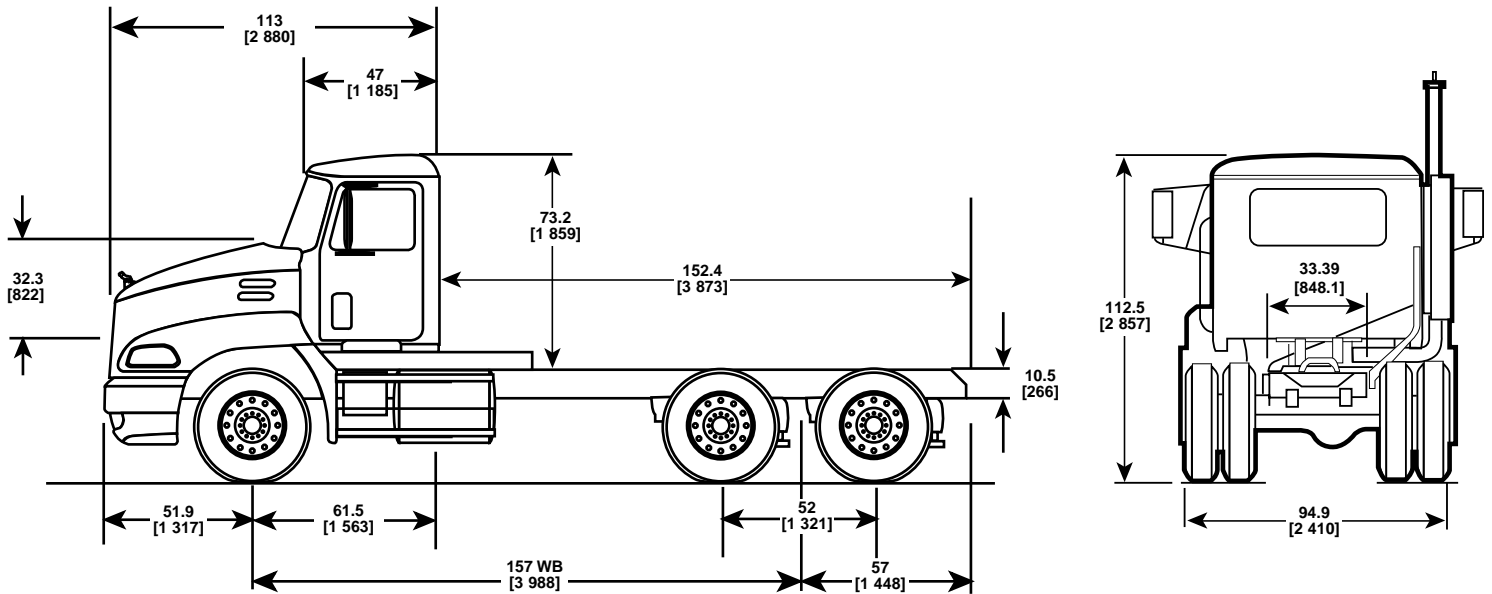

AVAILABLE DRIVELINE COMPONENTS

TRANSMISSIONS		
MODEL	SPEEDS	RATIOS (LOW/HIGH)
MACK		
T309	9	11.40/0.71
T309(L)	9	13.93/0.71
T309(LR)	9	13.93/0.71
T310	10	13.81/0.73
T310M	10	17.35/0.73
T310ME	10	17.35/0.73
T313LR	13	16.42/0.71
T313 L	3	16.42/0.71
T318LR	18	16.42/0.71
T318L	18	16.42/0.71
T318L21	18	16.42/0.71
ALLISON		
4000 HS	5	3.51/0.74
4000 HS	6	3.51/0.64
4500 HS	5	4.70/0.76
4500 HS	6	4.70/0.67
FULLER		
RTX-13609B	9	12.57/0.73
RTX-14609B	9	12.57/0.73
RTX-16709B	9	12.46/0.73
FR-13210B	10	14.80/1.00
FR-14210B	10	14.80/1.00
FRO-13210B	10	11.06/0.75
FRO-13210C	10	12.69/0.74
FRO-14210B	10	11.06/0.75
FRO-14210C	10	12.69/0.74
FRO-15210B	10	11.06/0.75
FRO-15210C	10	12.69/0.74
FRO-16210B	10	11.06/0.75
FRO-16210C	10	12.69/0.74
RTO-14908LL	10	14.56/0.74
RTO-16908LL	10	14.56/0.74
RTO-16909ALL	11	26.08/0.73
RTLO-14913A	13	12.31/0.73
RTLO-16913A	13	12.31/0.73
RT-14915	15	16.94/1.00
RTO-14915	15	13.29/0.79
RTO-16915	15	13.29/0.79
RTLO-14918B	18	14.40/0.73
RTLO-16918B	18	14.40/0.73
FULLER LIGHTNING TOP 2		
FRLO-14410C-T2	10	12.66/0.74
FRLO-15410C-T2	10	12.66/0.74
FRLO-16410C-T2	10	12.66/0.74

ENGINES			
MODE	*HORSEPOWER @ GOV'D. RPM	MODEL	*HORSEPOWER @ GOV'D. RPM
MACK—ASET CEGR			
AC-310/330	310 HP [231 kW] @1800 330 HP [246 kW] @ 1400-1500	AC-400	400 HP [298 kW] @1800 400 HP [298 kW] @ 1500-1800
AC-330/350	330 HP [246 kW] @1800 350 HP [261 kW] @ 1400-1500	AC-427	427 HP [318 kW] @1800 427 HP [318 kW] @ 1600-1800
AC-355/380	355 HP [265 kW] @1800 380 HP [284 kW] @ 1400-1500	AC-460P	460 HP [343 kW] @1850 487 HP [363 kW] @ 1600-1700
AC-380/410	380 HP [238 kW] @1800 410 HP [305 kW] @ 1400-1500	AC-460E (ECONOMY)	460 HP [343 kW] @1800 460 HP [343 kW] @ 1600-1800
AC-350	350 HP [261 kW] @1800 350 HP [261 kW] @ 1500		

TRANSMISSIONS (Continued)					
MODEL	SPEEDS	RATIOS (LOW/HIGH)	MODEL	SPEEDS	RATIOS (LOW/HIGH)
FULLER LIGHTNING W/O TOP 2					
FRLO-14410C	10	12.66/0.74	FRLO-16410C	10	12.66/0.74
FRLO-15410C	10	12.66/0.74			
GENERATION II—FULLER AUTO SHIFT					
RTO-14910B-AS2	10	10.96/0.74	RTO-16910C-AS2	10	12.80/0.73
RTO-16910B-AS2	10	10.96/0.74	RTLO-14918C-AS2	18	12.19/0.73
RTO-14910C-AS2	10	12.80/0.73	RTLO-16918C-AS2	18	19/0.73
GENERATION II—FULLER ULTRA SHIFT					
RTO-14910B-DM2	10	10.96/0.74	RTO-16910B-DM2	10	10.96/0.74
MERITOR					
M-14G10A-M14	10	15.02/1.00	MO-13G10C-M13	10	12.72/0.73
M-15G10A-M15	10	15.02/1.00	MO-14G10A-M14	10	11.19/0.74
MO-11G10A-M11	10	11.19/0.74	MO-14G10C-M14	10	12.72/0.73
MO-11G10C-M11	10	12.72/0.73	MO-15G10A-M15	10	11.19/0.74
MO-13G10A-M13	10	11.19/0.74	MO-15G10C-M15	10	12.72/0.73

AXLES—See Page 4

AVAILABLE DRIVELINE COMPONENTS (Continued)

AXLES								
CAPACITY	MAKE	MODEL	CAPACITY	MAKE	MODEL	CAPACITY	MAKE	MODEL
FRONT AXLES			TANDEM REAR AXLES/SUSPENSION					
12,000 lb. [5 443 kg]	DANA SPICER	E1202I	38,000 LB. [17 237 kg]	MACK	S38R	44,000 lb. [19 958 kg]	MACK	S440
	MERITOR	FF961 or FF981		DANA SPICER	DS405(P) DST40(P)/41(P)		MACK	S440/462
14,600 lb. [6 623 kg]	MACK	FXL 14.6	40,000 lb. [18 414 kg]	MERITOR	RT40-145A RT40-160	46,000 lb. [20 866 kg]	MERITOR	RT46-160 RT46-164

FRAME:

Optional Frame Rails

Rail Dimensions: 10.47" x 3.54" x .28" [266 x 90 x 7 mm]
 Section Modulus: 13.3 in.³ [217.9 cm³]
 Resisting Bending Moment, RBM: 1,600,000 lbs. in. [180 000 N•m]

Rail Dimensions: 10.47" x 3.54" x .32" [266 x 90 x 8 mm]
 Section Modulus: 15.0 in.³ [245.8 cm³]
 Resisting Bending Moment, RBM: 1,810,000 lbs. in. [203 000 N•m]

Rail Dimensions: 11.81" x 3.54" x .37" [300 x 90 x 9.5 mm]
 Section Modulus: 20.6 in.³ [337.6 cm³]
 Resisting Bending Moment, RBM: 2,470,000 lbs. in. [279 000 N•m]

Wheelbase Availability

144" [3 658 mm] to 248" [6 299 mm]

CAB, INTERIOR TRIM LEVELS:

Trim Level I - Select: Pewter Gray Interior; Dark Fieldstone (Day Cab Only)
Trim Level II - Premium: Garnet Red, Glacier Blue, Desert Sand or Dark Fieldstone Interiors available; Graphite Gray (N/A with Sleepers)
 (Color is accent on base gray background)
Trim Level III - Elite: Garnet Red, Glacier Blue, Desert Sand or Dark Field Stone Interiors available. Features Ultra Leather Custom Pad Fabric Headliner.

SLEEPER BOXES: Interior Color Matches that of the Cab Interior; Sleeper Box Integral with Cab Mounting

- 48" [1 219 mm] Flat Top
- 56" [1 423 mm] Flat Top
- 60" [1 524 mm] Mid Rise
- 70" [1 778 mm] Mid Rise
- 70" [1 778 mm] High Rise

AERO AIDS: Roof Fairing, Side Shields, Roof Air Reflector

OTHER OPTIONAL EQUIPMENT:

- Air Compressor Options
- Air Dryer Options
- Air Horns
- Air Reservoirs, Aluminum
- Back-Up Alarm
- Battery Box Cover, Aluminum
- Battery Disconnect Switch
- Battery Options
- Brake Equipment Options
- Bright Finish Equipment:
 - Air Reservoirs
 - Battery Box Cover
 - Bumper
 - Exhaust Systems
 - Fuel Tanks
 - Mirrors and Brackets
 - Steps
 - Wheels, Disc
 - Bug Screen
- Bumper—Stainless Steel, Clad Aluminum, Painted Steel
- CB Radio Options
- Cab Accessories
- Chassis Keyed Alike
- Clutch, Self-Adjusting
- Coolant Protection to -40°F
- Crossmember Options
- Drain Valve, Automatic
- Driveline, Increased Size

- Electrical Circuit Breaker
- Electrical:
 - Starter Options
 - Alternator Options
- Engine Brake
- Engine Cold Starting Aids
- Engine Heaters
- Exhaust, Dual Vertical
- Fifth Wheels and Related Equipment
- Fog/Driving Lights
- Fuel Heaters
- Fuel System:
 - Fast Fill & Accessory Options
 - Dual Draw
- Fuel/Water Separators
- Gauge Cluster Options:
 - Air Application
 - Axle Oil Temperature
 - Engine Oil Temperature
 - Exhaust Pyrometer
 - Manifold Pressure
 - Transmission Oil Temperature
- Hubodometer
- Inside/Outside Air Intake
- Interwheel Power Divider
- Inversion Valve, Spring Brakes
- Mirror Options
- Paint Designs (Cab & Hood)
- Power Take-Off Options & Clearances

- Power Windows and Door Locks
- Quarter Fenders
- Radio Options, Stereo/Cassette/CD
- Rear Axle Carrier Options
- Seat Options, Driver & Rider
- Sleeper Box Interior Options
- Sun Visor, Exterior
- Suspension, Rear Axle: Multileaf or Air
- Synthetic Lubricants
- Tires
- Trailer Access Packages
- Trailer Connection Packages & Accessory Options
- Trailer Hook-Up Lamp
- Transistorized Flashers
- Transmission Cooler
- VIP (Vehicle Information Profiler)
- Vinyl Stripe Designs (Cab & Hood)
- Wheel Equipment:
 - Spoke, Steel or Aluminum Disc
 - Hub & Drum Equipment
- Wheel Seals

**OTHER COMPONENT OPTIONS
MAY BE AVAILABLE UPON REQUEST.**

The information in this brochure was accurate as known as of the date of the publication. Illustrations may not be representative of current product. Mack Trucks, Inc. reserves the right to make changes in specifications, equipment or design, or to discontinue models or options without notice at any time.