

# MACK

# ENGINE

## MP8 US07

### 415C

### FEATURES

- High Torque MAXICRUISE™ Diesel Engine
- Cooled Exhaust Gas Recirculation (CEGR)
- Maximum Horsepower 415 BHP [309 kW]
- Electronic Unit Pump Fuel Injection with Rate Shaping
- V-MAC IV Total Vehicle Electronics System
- Wide Operating Range 1200-1950 RPM
- Chassis Mounted Charge Air Cooled
- Variable Geometry Turbocharger
- Extended Service Intervals
- MACK PowerLeash Engine Brake

### SPECIFICATIONS

Peak HP (kW) @ RPM ..... 415 [309] @ 1500-1700  
 HP [kW] @ Governed RPM ..... 390 [291] @ 1950  
 Max. Torque lb. ft. [N•m] @ RPM ..... 1,660 [2 251] @ 1200  
 Type ..... Direct Injection Diesel  
 Number of Cylinders ..... 6, In-Line  
 Bore & Stroke, in. [mm] ..... 5.16 x 6.22 [131 x 158]  
 Displacement ..... 13  
 Compression Ratio ..... 16:1  
 Firing Order ..... 1-5-3-6-2-4  
 Torque Rise ..... 58%  
 Clutch Engagement ..... 720 lb. ft. [976 N•m] @ 800 RPM  
 Idle Speeds:  
 Low ..... Adjustable; 650 RPM  
 High ..... Adjustable; 2100 RPM  
 Engine Brake Retarding Power (If Applicable)  
 ..... 435 HP [324 kW] @ 2100 RPM  
 Weight, Dry: (Approx.) ..... 2,560 lbs. [1 161 kg]  
 (With air compressor, but no oil, water, starter, fan, alternator, or clutch)

### V-MAC IV® FUNCTIONS

4th Generation Vehicle Management And Control System

#### V-MAC IV PRODUCTIVITY FEATURES:

- PTO (4) and Electronic Hand Throttle Control
- Engine “Smart Fan Control”
- Integrated Sleeper Low Voltage Disconnect †
- “Smart Idle” Speed Regulator
- GuardDog Routine Maintenance Monitoring †

#### V-MAC IV DRIVER CONVENIENCE FEATURES:

- Full Featured Cruise Control
- Cruise 'n Brake Engine Brake Control
- Programmable Engine Governor Type
- Idle Cooldown
- Daytime Running Light (DRL) Override †

#### V-MAC IV FUEL ECONOMY FEATURES:

- Vehicle Speed Limiting
- Engine “Sweet Spot Indicator”
- Fuel Economy Incentive Program
- Idle Shutdown
- Integrated Temp-A-Start †

#### V-MAC IV RELIABILITY FEATURES:

- Engine Protection
- Starter Protection
- Differential Lock Auto Control

#### V-MAC IV FLEET MANAGEMENT FEATURES:

- DataMax Comprehensive On-Board Data Logger
- InfoMax PC Fleet Management Software

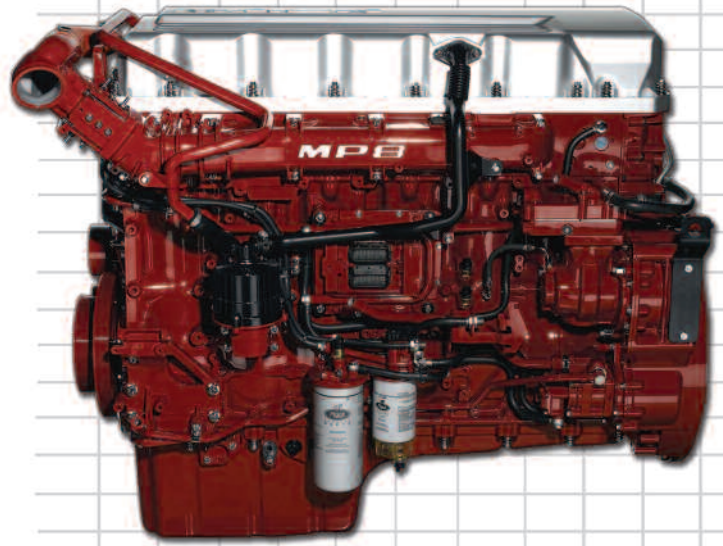

#### V-MAC IV SAFETY AND SECURITY FEATURES:

- Speed Sensor Tamper Resistance
- Theft Deterrence
- 5th Wheel Slide Unlocked Vehicle Speed Limiting
- Air Suspension Deflated Vehicle Speed Limiting

#### V-MAC IV SERVICEABILITY FEATURES:

- SAE J1587 and J1939 Diagnostic Port
- Electronic Fault Logging with Fault Reporter
- VCADS PC Based Service Software

† Denotes an available option.

### ENGINE PERFORMANCE

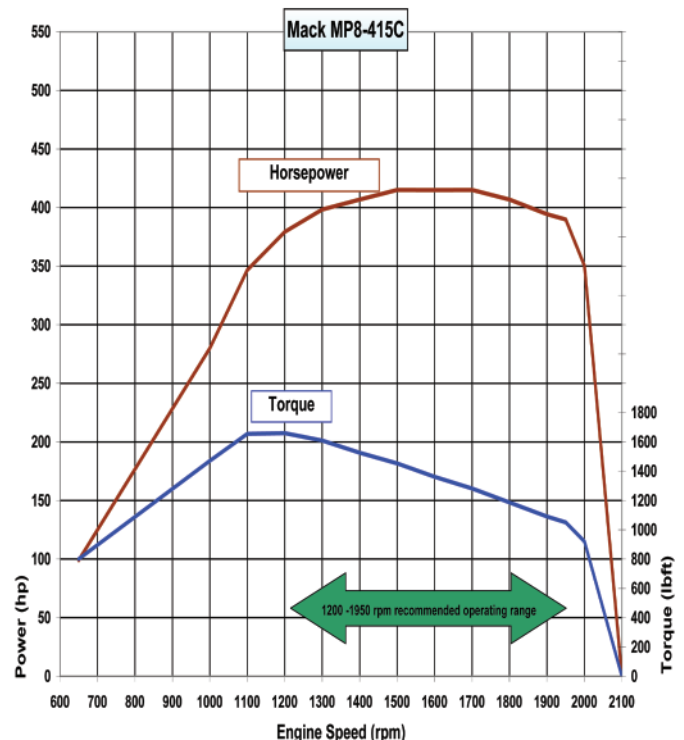

## ENGINE SPECIFICATIONS

- Flywheel Housing ..... Die cast Aluminum
- Cylinder Block:
  - Material ..... Alloyed Grey Cast Iron
  - Ladder Frame Reinforcement
- Cylinder Liners:
  - Type ..... Full Wet Design
  - Surface Finish ..... Plateau Honed
- Cylinder Head Assembly:
  - Type Grey Cast Iron Slab Head With
    - Intermediate Deck
    - Single Overhead Cam
  - Configuration ..... 4 Valves/Cyl., OHV
  - Valve Type ..... Poppet
  - Valve/Insert Material ..... Super Alloy (Serviceable)
- Pistons & Rings:
  - Piston Type ..... Monotherm™ Single Piece Steel
    - w/Closed Cooling Gallery
  - Pin Diameter ..... 2.125" [54 mm]
  - Rings ..... 2 Compression, 1 Oil Control
- Crankshaft:
  - Material ..... Forged, Carbon Steel
  - Heat Treatment ..... Induction-Hardened Journals/Fillet
  - Main Bearing Diameter ..... 4.5" [114 mm]
- Charge Air Cooling ..... Chassis Mounted, Air-To-Air
- Fuel System ..... Delphi E3 Electronic Unit Injectors
  - w/2 Solenoid Valve Technology and Rate Shaping
- Fuel Supply Pump ..... ZF Meritor
- Filter ..... Spin On, Disposable
- Lubrication System:
  - Type Full Pressure, Wet Sump
  - Oil Filters ..... 2 Spin-On Full Flow Disposable,
    - 1 By-pass
  - Oil Cooler ..... Stainless Steel Plate
  - Total Oil Capacity ..... 36 qts. (Incl's. Filters)
  - Drain Plug ..... Magnetic
- Cooling System:
  - Capacity ..... 17 qts. [16 L]
  - Thermostats ..... 180°F [82°C]
  - Hose Material ..... Silicone
- Air Compressor:
  - Type ..... Meritor/WABCO
  - Standard Capacity:
    - CHU, CXU, GU7 and GU8 ..... 18.7 cfm [8.9L/s]
    - MRU, LEU ..... 37.4 cfm [17.8L/s]
- Turbocharger ..... Holset, Sliding Nozzle Ring Variable
  - Geometry w/Water Cooled Actuator and Bearings
  - and Electronic Controls
- Accessory Belt ..... Poly-V w/Automatic Tensioners
- EGR System
  - Single EGR Valve Assembly ... Modulated Cast Stainless Steel
  - EGR Cooler ..... Stainless Steel Tube
    - and Insert, Gas to Coolant

## GEARING RECOMMENDATIONS

Proper gearing is necessary to achieve optimum vehicle performance and fuel economy. Vehicle specifications, including engine, transmission, axle ratio, and tire selection, should generally be selected to meet the following criteria:

<b>Startability</b>	Highway Applications ..... ≥ 10%
	On-Off Highway Applications ..... ≥ 16%
<b>Gradeability</b>	@ Cruise Max. MPH ..... ≥ 0.5%
	@ Peak Torque, Top Gear ..... ≥ 1.5%
<b>Cruise RPM</b>	1500 ±50 RPM*

\*Cruise RPM = Engine speed in top gear @ Cruise Max. MPH setting. Limited to 65 MPH. At higher speeds gear truck to obtain above RPM @ 65 MPH.

Refer to the MACKTRAQ® electronic sales tool to obtain startability, gradeability and cruise RPM results for specific vehicle specifications. Special service applications, road surfaces, high GCW's or other factors may require different gearing considerations.

## DIMENSIONS

### Conventional Chassis

(CHU, CXU, GU7 AND GU8 MODELS)

LEFT SIDE VIEW

FRONT VIEW

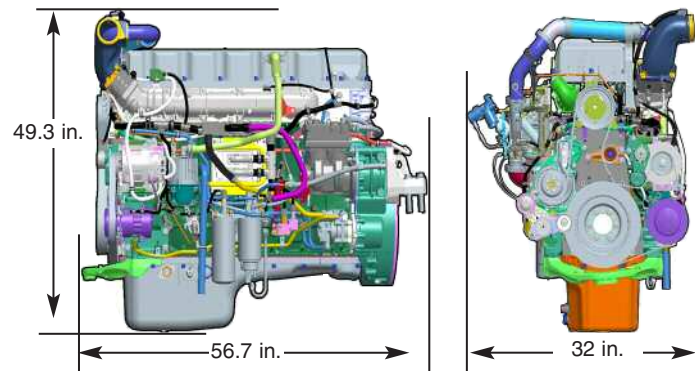

### LCF Chassis

(MRU AND LEU MODELS)

LEFT SIDE VIEW

FRONT VIEW

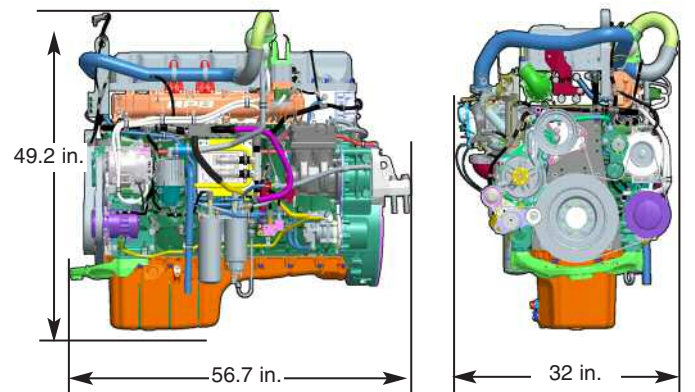

## OIL/FILTER SERVICE INTERVALS

Refer to the latest version of Mack Maintenance & Lubrication Manual TS494.

## OPTIONAL EQUIPMENT\*

- High Capacity Air Compressor
- 120 and 240 Volt Engine Block Heaters
- High Capacity Alternator

\*\* Availability may be chassis model dependent.