

Engineering Release Notice (ERN)	Location	Change Description	A = Added D = Deleted	W = Was	Document Release Status
D-18959-22		See DCN			Date <b>RELEASED</b>
					Modification Count

## WIRING DIAGRAM INDEX

NAME	DESCRIPTION	PAGE
AA	POWER DISTRIBUTION 1/2	2
AB	POWER DISTRIBUTION 2/2	3
AC	KEY SW, START & CHARGING	4
AD	GROUNDING	5
BA	VEHICLE ECU 1/5	6
BB	VEHICLE ECU STWPOS-D 2/5	7
BC	VEHICLE ECU 4/5 - DCL CONNECTOR	8
BD	VEHICLE ECU 5/5	9
BE	INSTRUMENT CLUSTER 1/3	10
BF	INSTRUMENT CLUSTER 2/3	11
BG	INSTRUMENT CLUSTER (SECONDARY CLUSTER) 3	12
BH	ALLISON BODYBUILDER INTERFACE	13
BN	REFUSE (RP-170)	14
BP	RP 170 BODYBUILDER 1/2	15
BQ	VEHICLE ECU STWPOS-R 5/5	16
BW	TGW2	17
BX	PRECO	18
BY	TMC RP1226 DRIVECAM PREP KIT	19
CA	ENGINE INTERFACE MACK	20
CC	ENGINE HEATER	21
CD	AUXILIARY COOLING FANS	22
CG	CNG FUEL LEVEL	23
CH	UREA DOSING SYSTEM	24
CI	METHANE DETECTION	25
CJ	ENGINE INTERFACE CUMMINS ISLG OBD 2018	26
DC	TRANSMISSION CONTROL 5th GENERATION 1/3	27
DD	TRANSMISSION CONTROL 5th GENERATION 2/3	28
DE	TRANSMISSION CONTROL 5th GENERATION 3/3	29
EA	ABS - MERITOR	30

NAME	DESCRIPTION	PAGE
EE	ABS BENDIX 8 CPC	31
EF	ABS BENDIX 8 CPC	32
FA	AIR DRYER/HEATED DRAIN	33
FB	CHASSIS SOLENOIDS	34
FC	MUNCIE PUMP, BEACON LAMPS & WORKBRAKE SO	35
FD	PARKER PTO	36
GA	LIGHTING - CONTROLS	37
GD	LIGHTING - FORWARD/SIGNAL	38
GF	LIGHTING - TAIL LAMP	39
GG	LIGHTING - TRAILER CONTROL	40
GH	LIGHTING - LH/RH CONTROL & INTERIOR	41
GP	WINDSHIELD WASHER	42
GQ	HORN WIRING	43
HA	CLIMATE CONTROL	44
IC	MIRRORS DUAL REMOTE	45
ID	MIRRORS DUAL REMOTE MEMORY	46
IE	POWER WINDOWS	47
IF	POWER DOOR LOCKS	48
JG	LANE DEPARTURE	49
KA	AUDIO & VISUAL SYSTEMS	50
KC	POWER OUTLET CONNECTIONS	51
NA	SPARE CONNECTIONS AND FEEDS	52
NB	JUNCTION POSTS	53
XA	OBD - DATA LINK 1 & DIAGNOSTICS - MACK E	54
XB	OBD - DATA LINK 1 & DIAGNOSTICS - 2018 C	55
XC	OBD - DATA LINK 2	56
XD	OBD - DATA LINK 4	57
XE	OBD - DATALINK 10	58

The copying, distribution and utilization of this document as well as the communication of its contents to others without expressed authorization is prohibited. Offenders will be held liable for payment of damages. All rights reserved in the event of the grant of a patent, utility model or ornamental design registration.

Document title

**WIRING DIAGRAM TYPE OL**

The legal owner of this document is as stated under "Design Location" in KOLA and in the associated "Part Version Report"

Document type

**PRODUCT SCHEMATICS**

Document No

**24403869**

Issue

**01**

Volume

**1 (1)**

Sheet No

**1 (58)**

**VOLVO**

Group Trucks Technology

POWER DISTRIBUTION 1/2

WIRING DIAGRAM: AA

BATT  
IGN  
EMS  
ILLUM

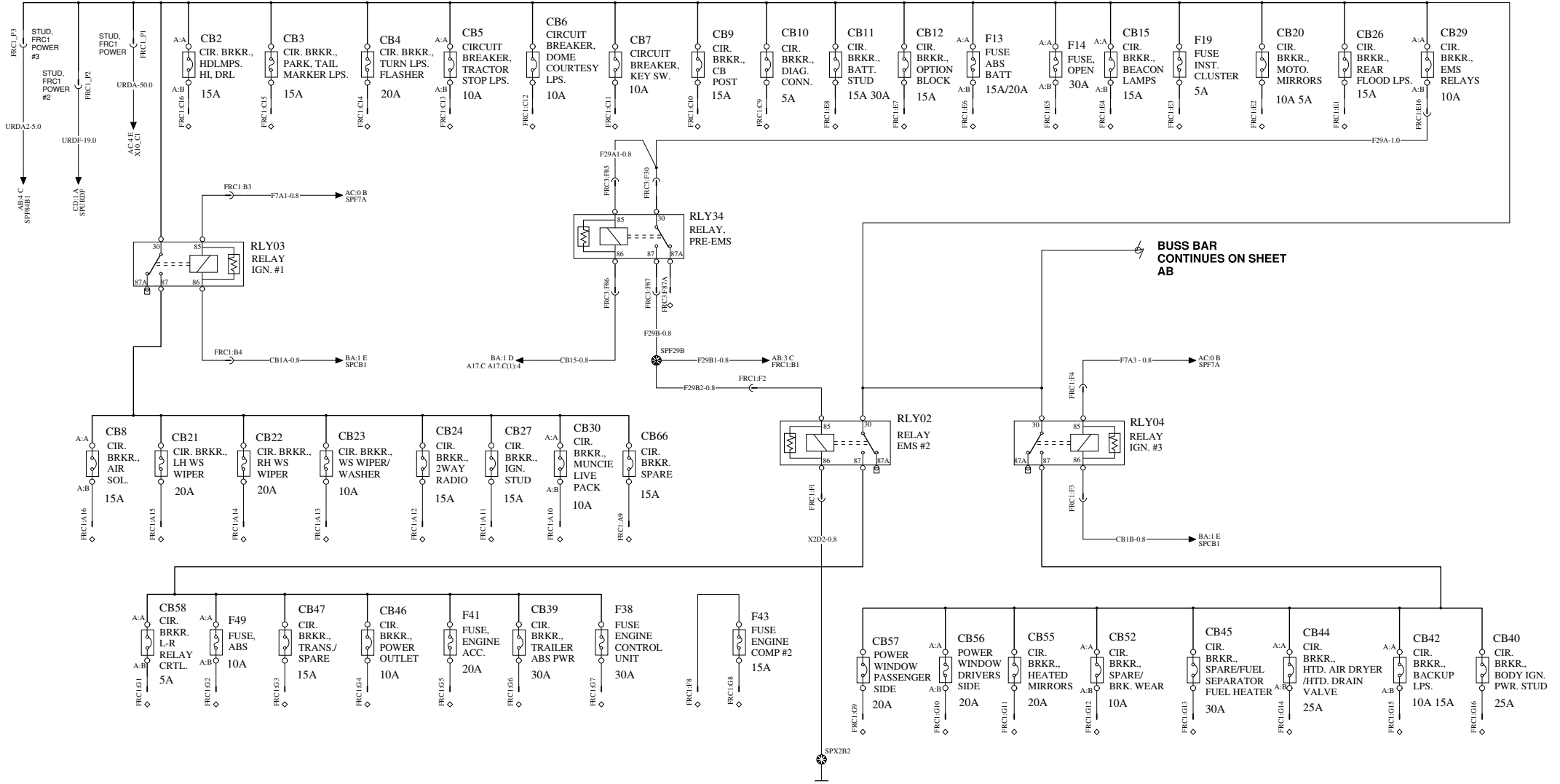

BUSS BAR  
CONTINUES ON SHEET  
AB

Volvo Truck Corporation

Document title WIRING DIAGRAM TYPE OL	Document No 24403869	Issue 01	Volume 1 (2)	Page 1 (57)
Document type PRODUCT SCHEMATIC				

POWER DISTRIBUTION 2/2

WIRING DIAGRAM: AB

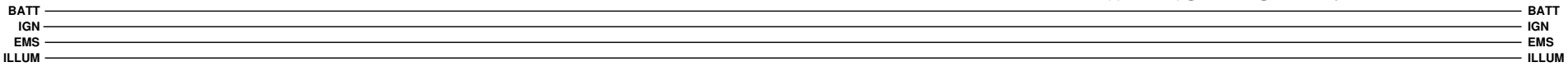

BUSS BAR  
CONTINUES ON  
SHEET  
AA

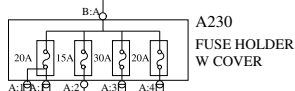
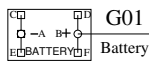
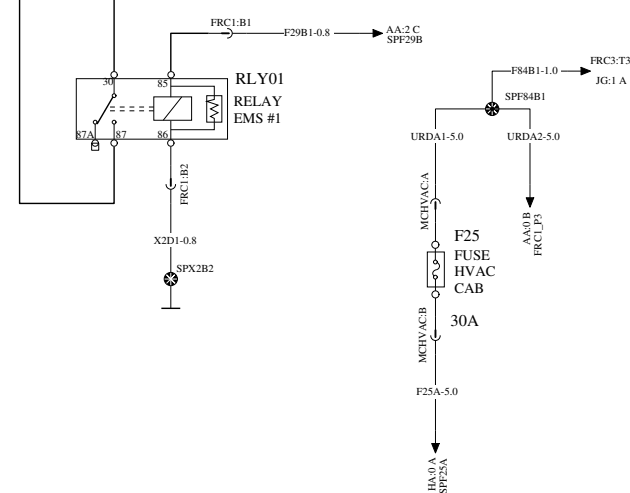
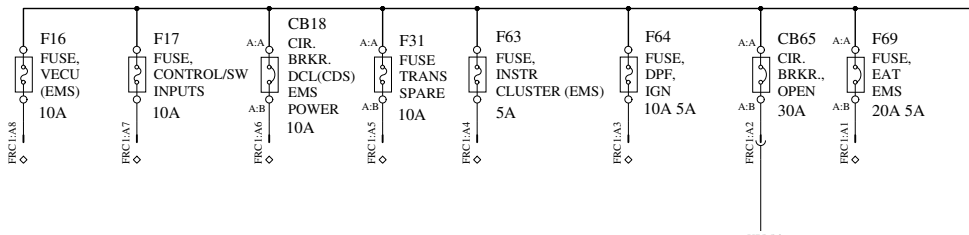
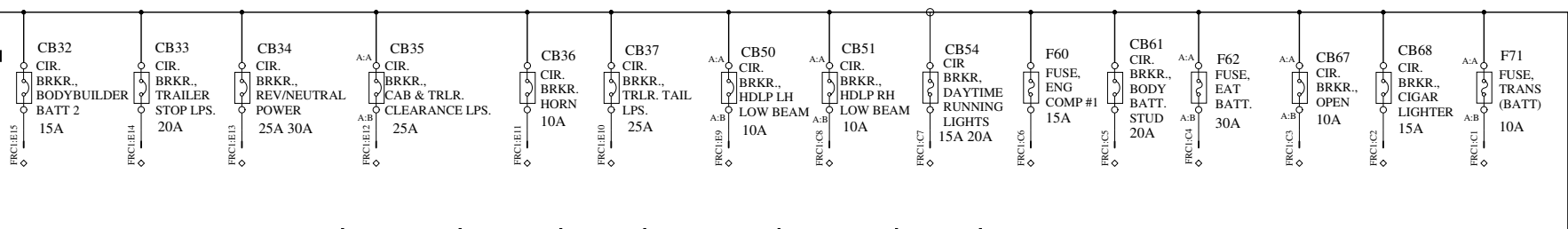

Document title  
WIRING DIAGRAM TYPE OL  
Document type  
PRODUCT SCHEMATIC

Document No	Issue	Volume	Page
24403869	01	1 (2)	2 (57)

Volvo Truck Corporation

# KEY SW, START & CHARGING

# WIRING DIAGRAM: AC

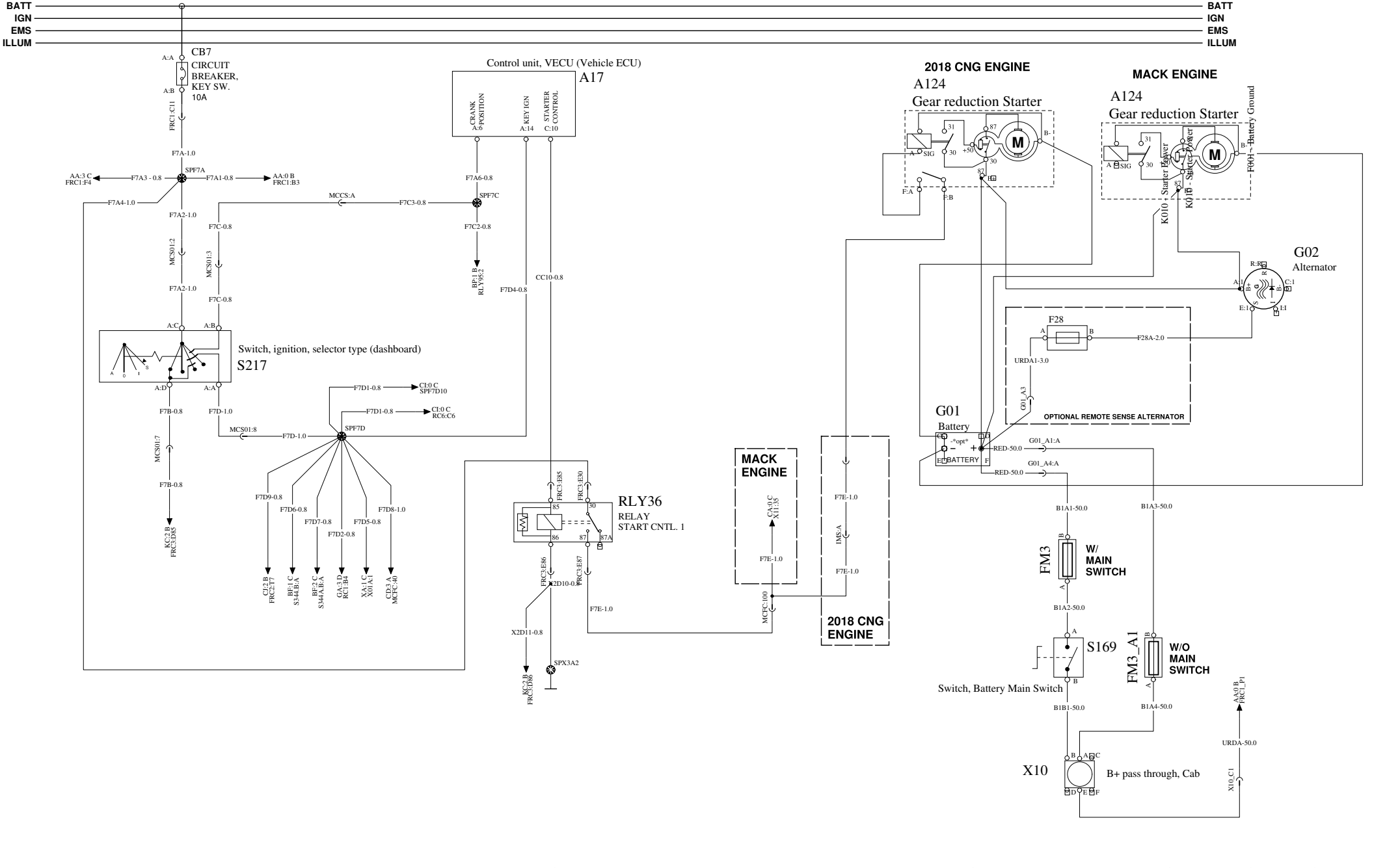

Document title	Document No	Issue	Volume	Page
WIRING DIAGRAM TYPE OL	24403869	01	1 (2)	3 (57)
Document type				
PRODUCT SCHEMATIC				

GROUNDING

WIRING DIAGRAM: AD

BATT  
IGN  
EMS  
ILLUM

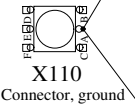
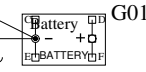
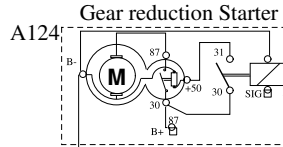
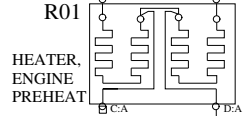

Battery Box Ground Stud

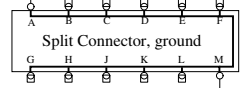
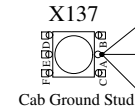
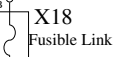
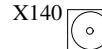

X111

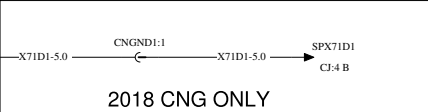
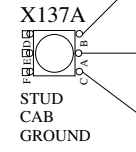
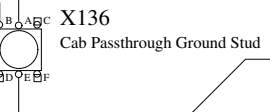

GROUND, ENGINE BLOCK,  
ALTERNATOR, PRE-HEATER

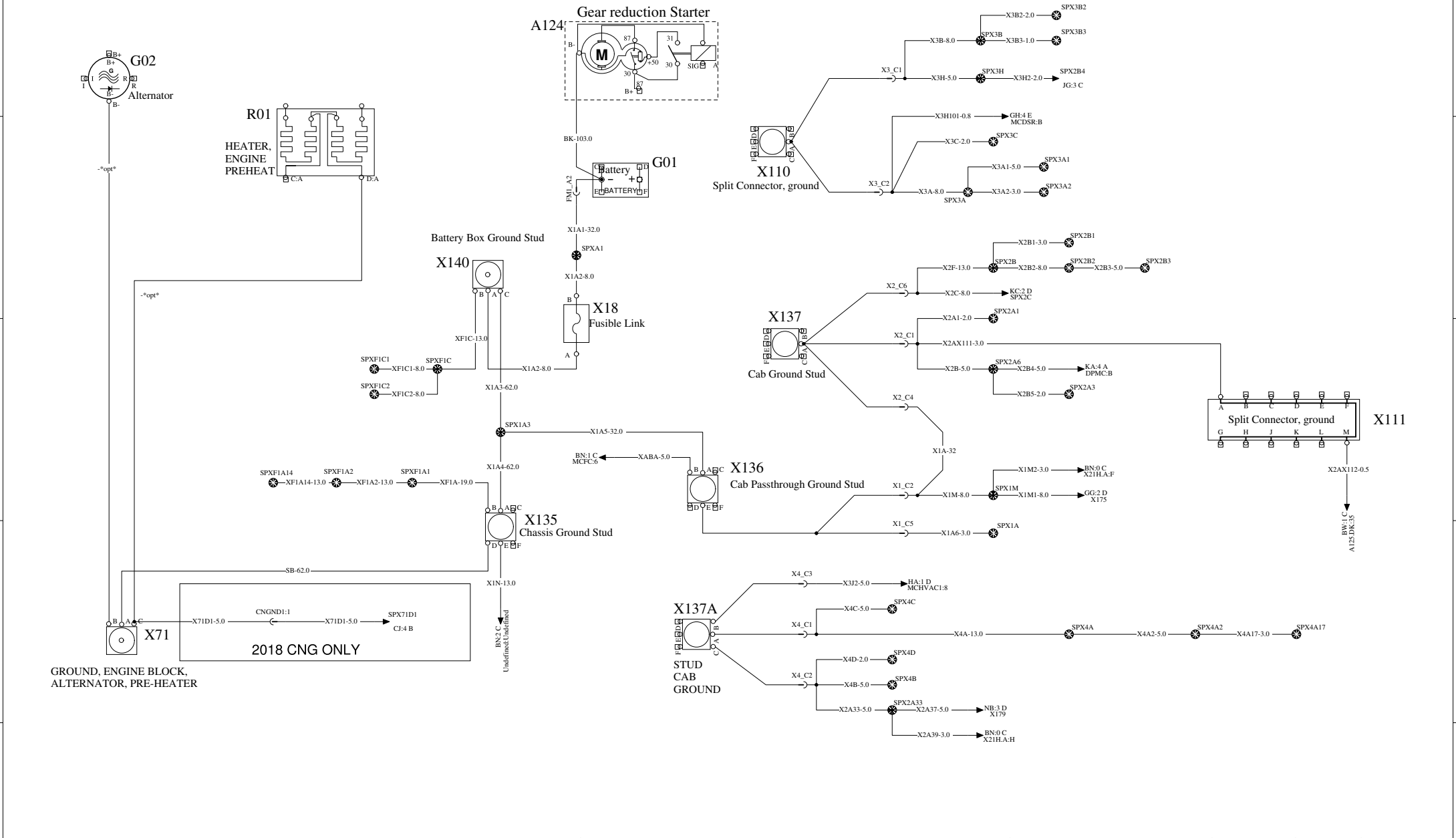

Volvo Truck Corporation		Document title WIRING DIAGRAM TYPE OL	Document No <b>24403869</b>	Issue 01	Volume 1 (2)	Page 4 (57)
		Document type PRODUCT SCHEMATIC				

VEHICLE ECU 1/5

WIRING DIAGRAM: BA

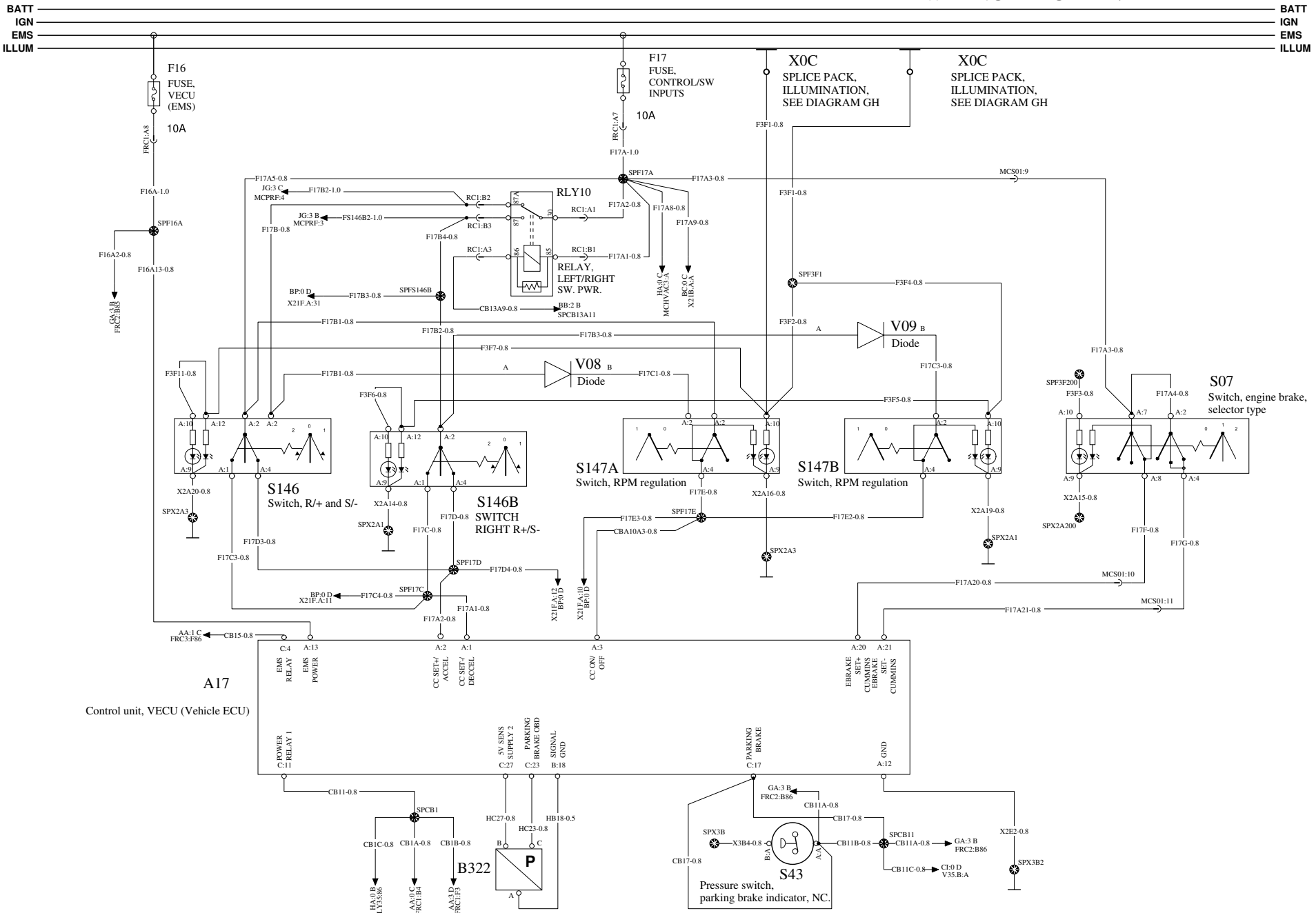

Document title WIRING DIAGRAM TYPE OL		Document No 24403869	Issue 01	Volume 1 (2)	Page 5 (57)
Document type PRODUCT SCHEMATIC					

VEHICLE ECU STWPOS-D 2/5

WIRING DIAGRAM: BB

BATT  
IGN  
EMS  
ILLUM

A

A

B

B

C

C

D

D

E

E

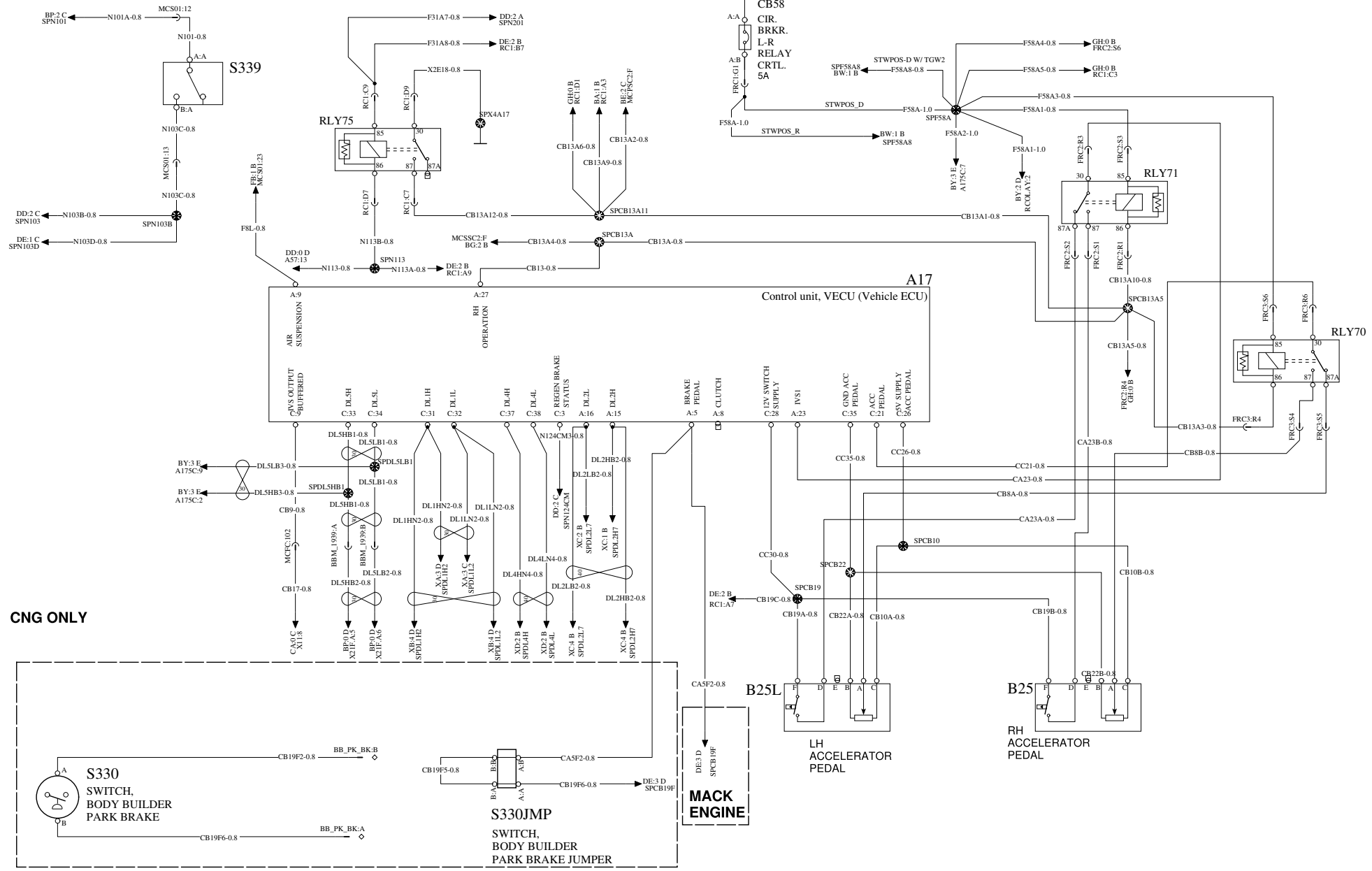

VEHICLE ECU 4/5 - DCL CONNECTOR

WIRING DIAGRAM: BC

BATT  
IGN  
EMS  
ILLUM

BATT  
IGN  
EMS  
ILLUM

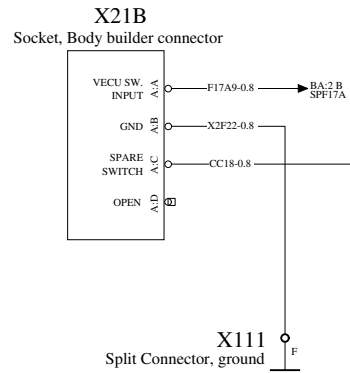

**X111**  
Split Connector, ground

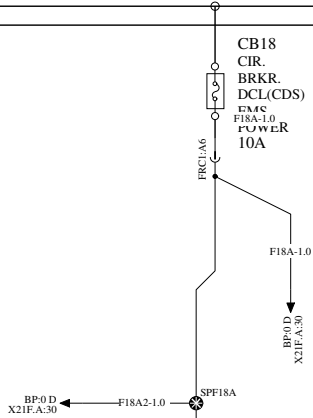
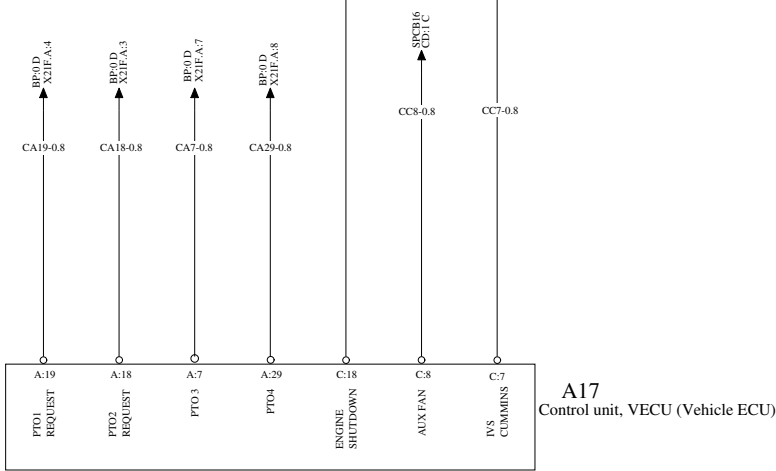

**R39A**  
RESISTOR,  
CUMMINS  
PULL UP  
IVS

**A17**  
Control unit, VECU (Vehicle ECU)



BATT \_\_\_\_\_ BATT  
 IGN \_\_\_\_\_ IGN  
 EMS \_\_\_\_\_ EMS  
 ILLUM \_\_\_\_\_ ILLUM

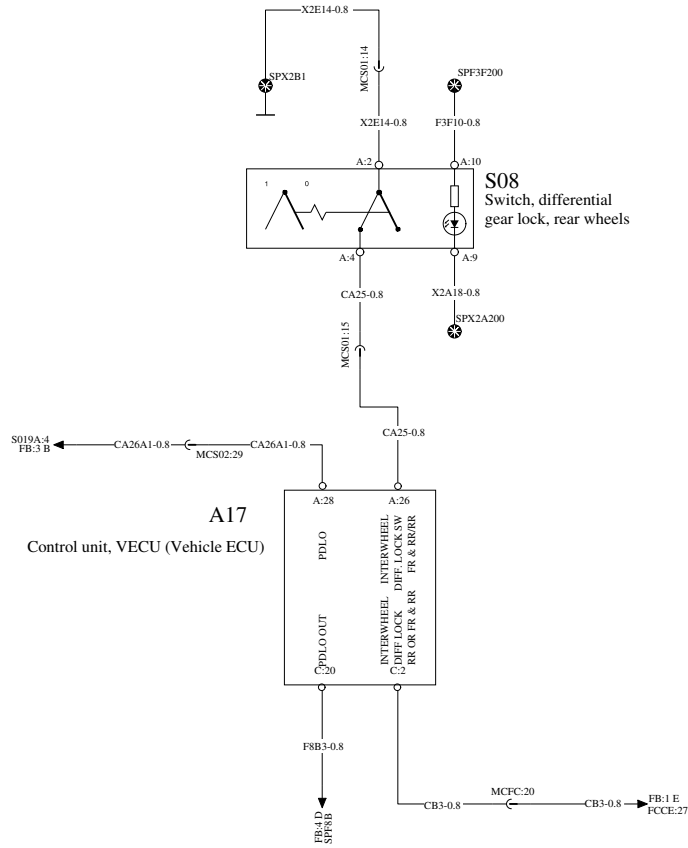

INSTRUMENT CLUSTER 1/3

WIRING DIAGRAM: BE

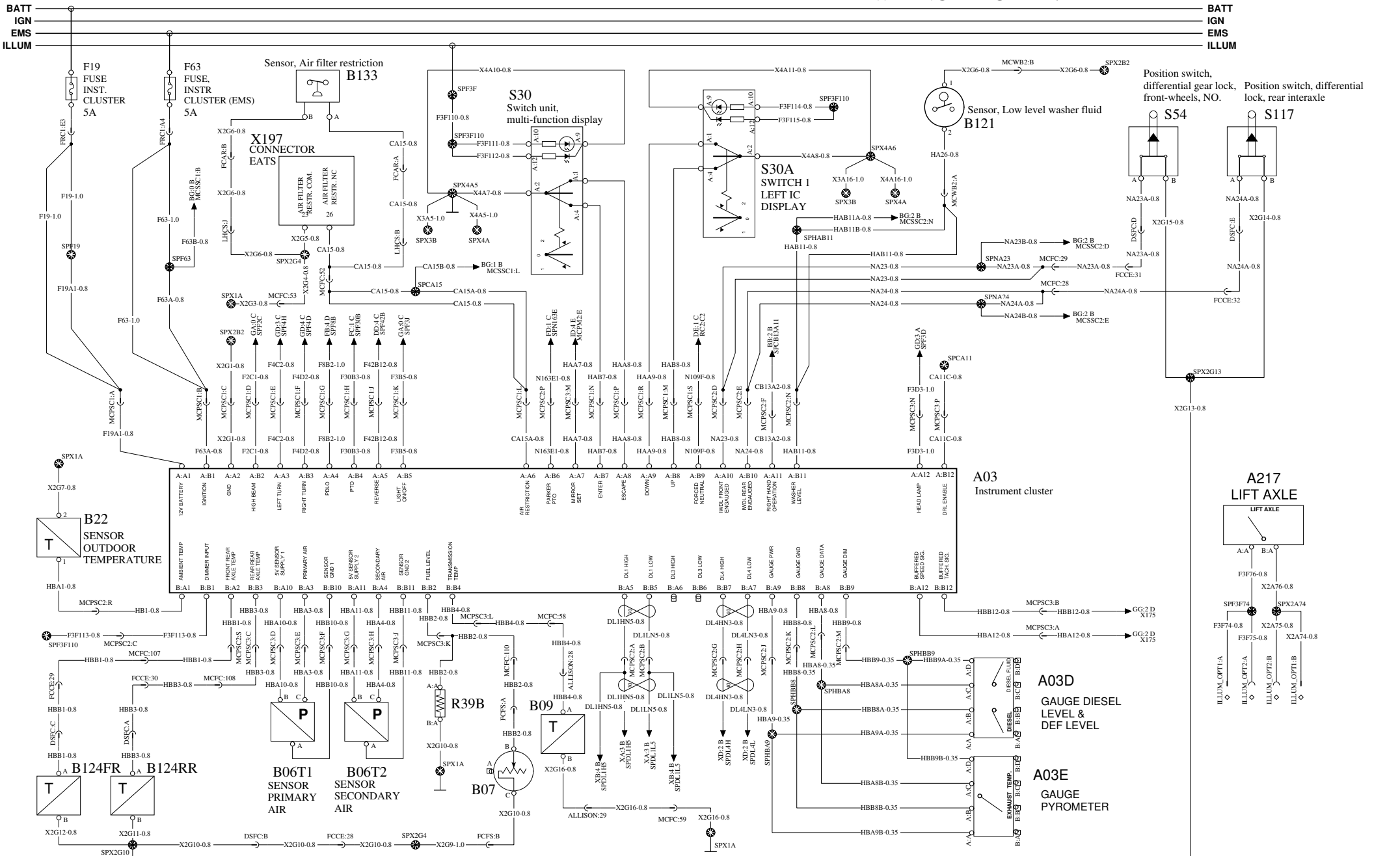

BATT  
IGN  
EMS  
ILLUM

BATT  
IGN  
EMS  
ILLUM

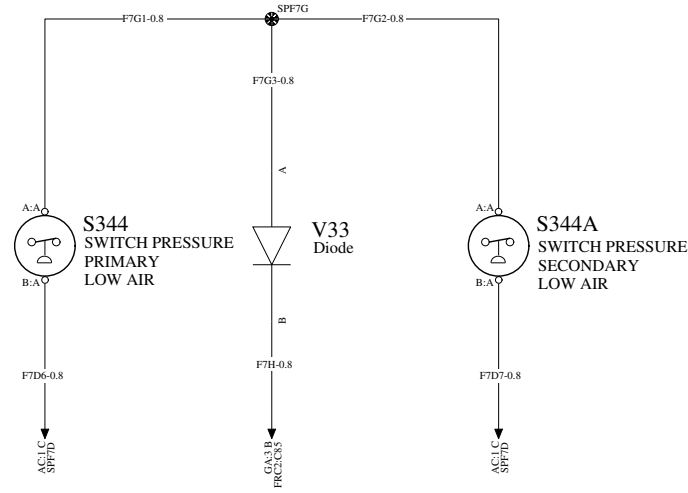

# INSTRUMENT CLUSTER (SECONDARY CLUSTER) 3/4

# WIRING DIAGRAM: BG

BATT  
IGN  
EMS  
ILLUM

BATT  
IGN  
EMS  
ILLUM

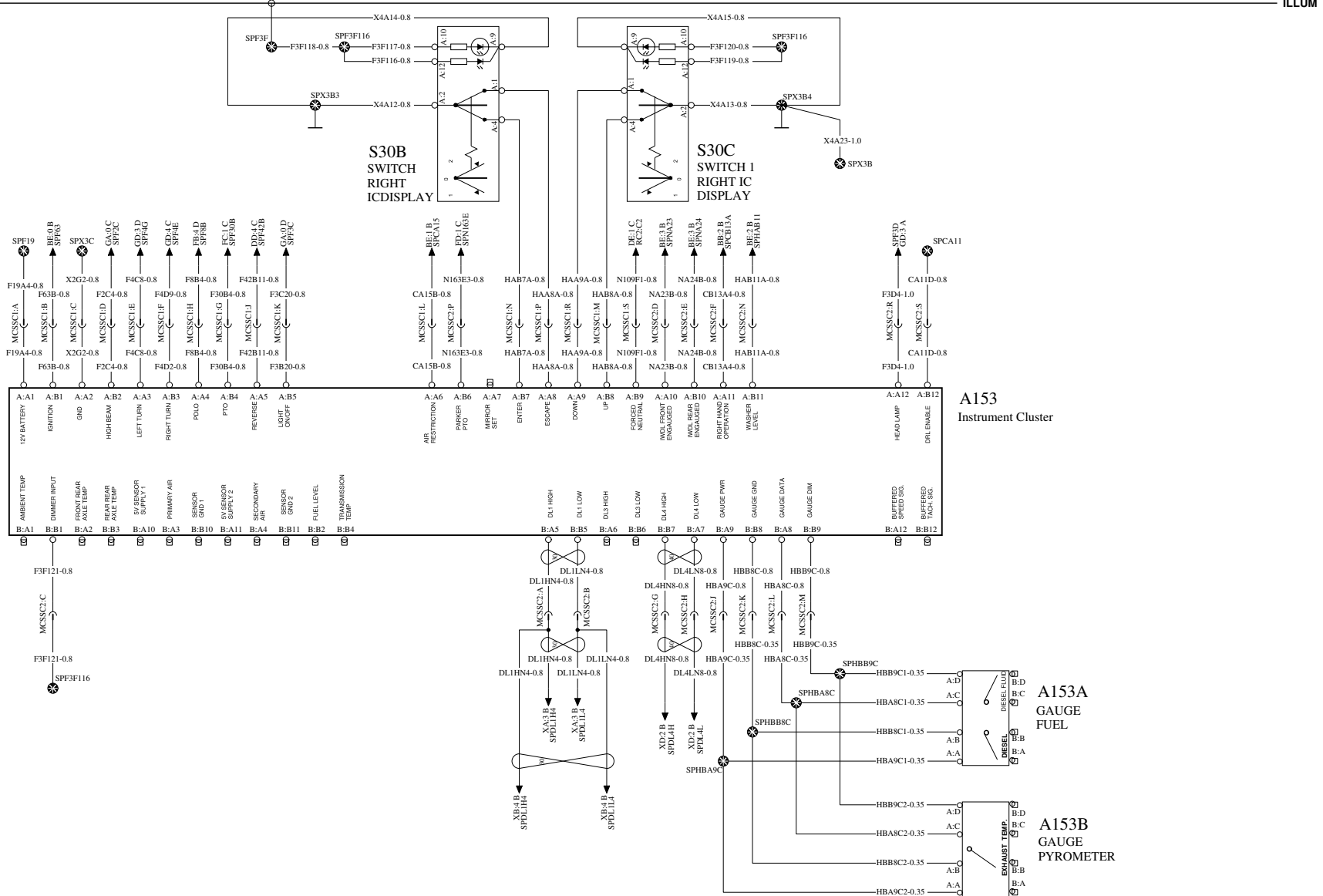

ALLISON BODYBUILDER INTERFACE

WIRING DIAGRAM: BH

BATT	_____	BATT
IGN	_____	IGN
EMS	_____	EMS
ILLUM	_____	ILLUM

**AVAILABLE WITH STWPOS-R ONLY**

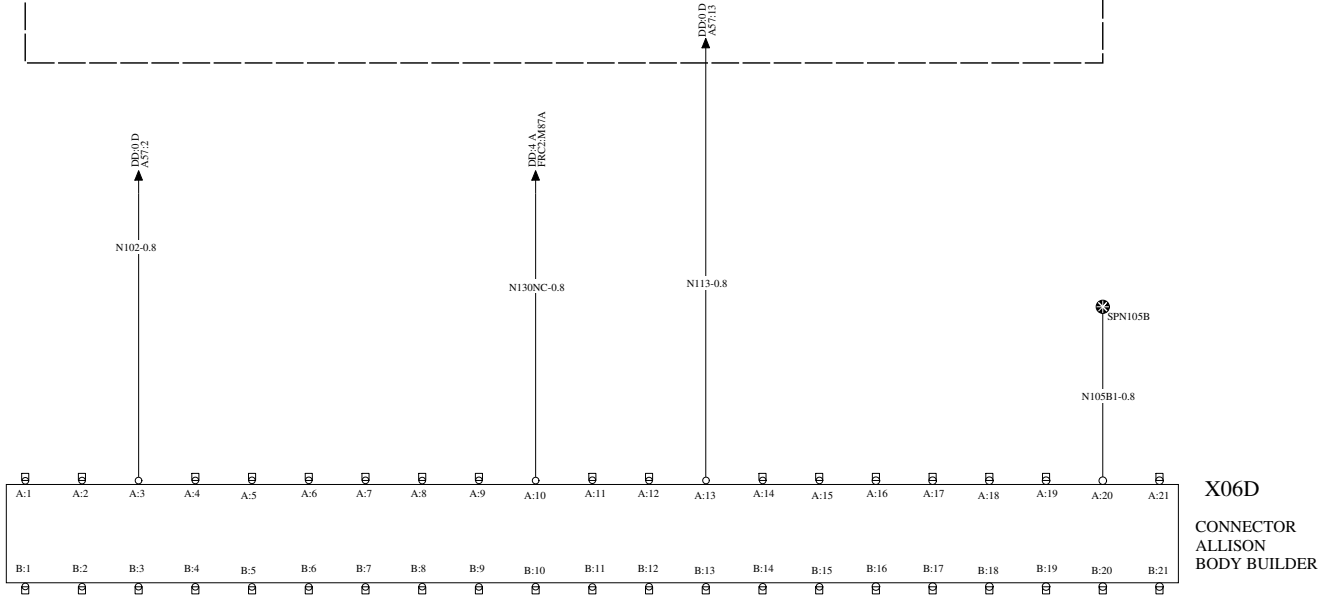

REFUSE (RP-170)

WIRING DIAGRAM: BN

BATT  
IGN  
EMS  
ILLUM

BATT  
IGN  
EMS  
ILLUM

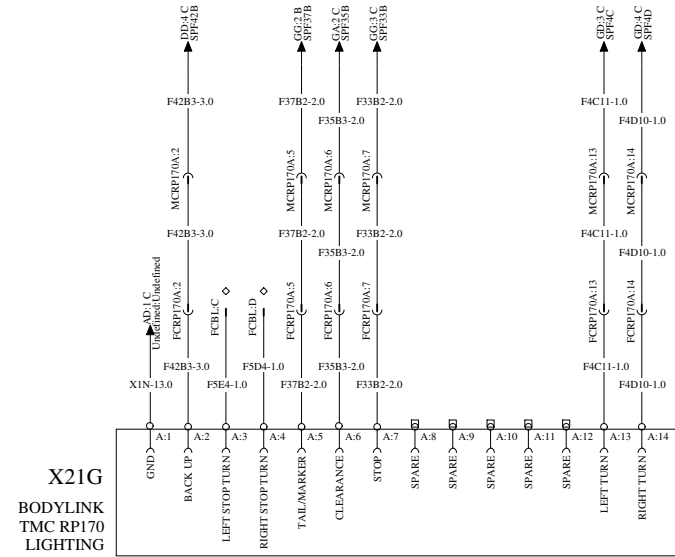
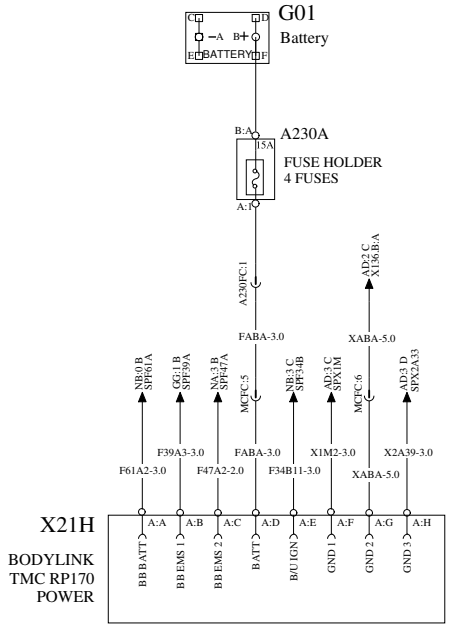

BATT \_\_\_\_\_ BATT  
 IGN \_\_\_\_\_ IGN  
 EMS \_\_\_\_\_ EMS  
 ILLUM \_\_\_\_\_ ILLUM

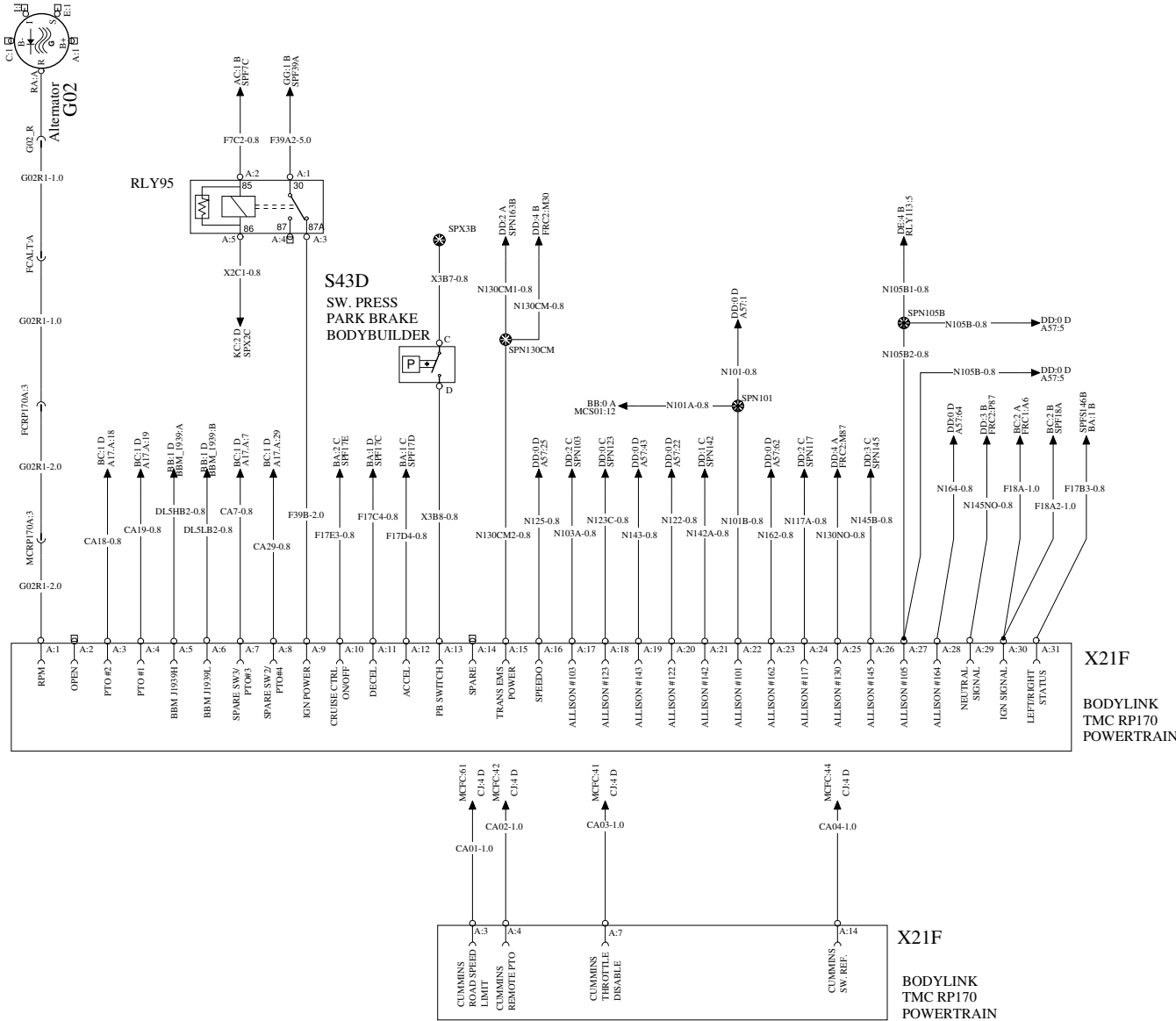

BATT  
IGN  
EMS  
ILLUM

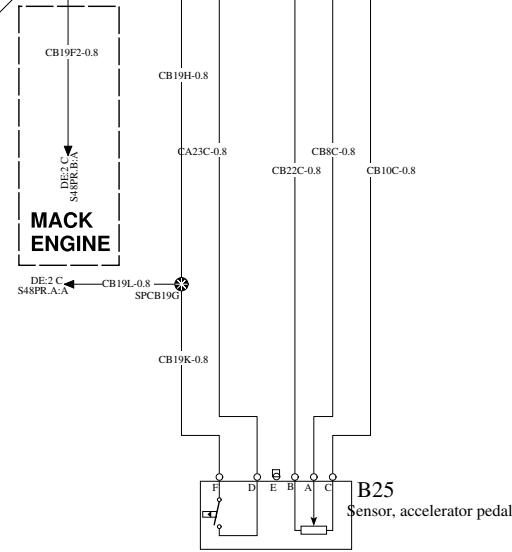
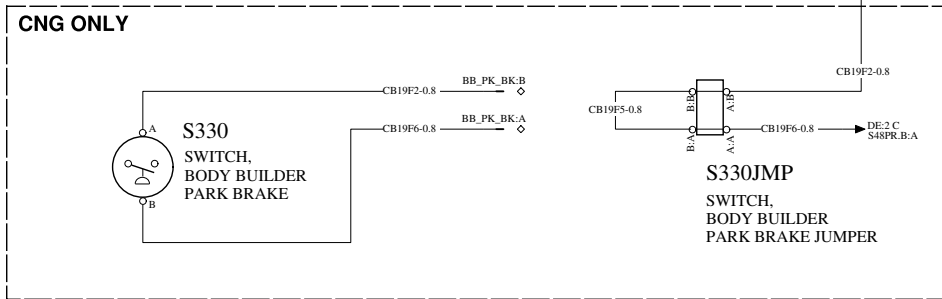
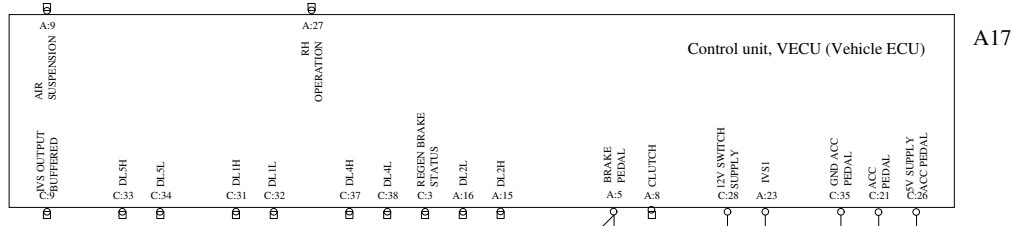



TGW2

WIRING DIAGRAM: BW

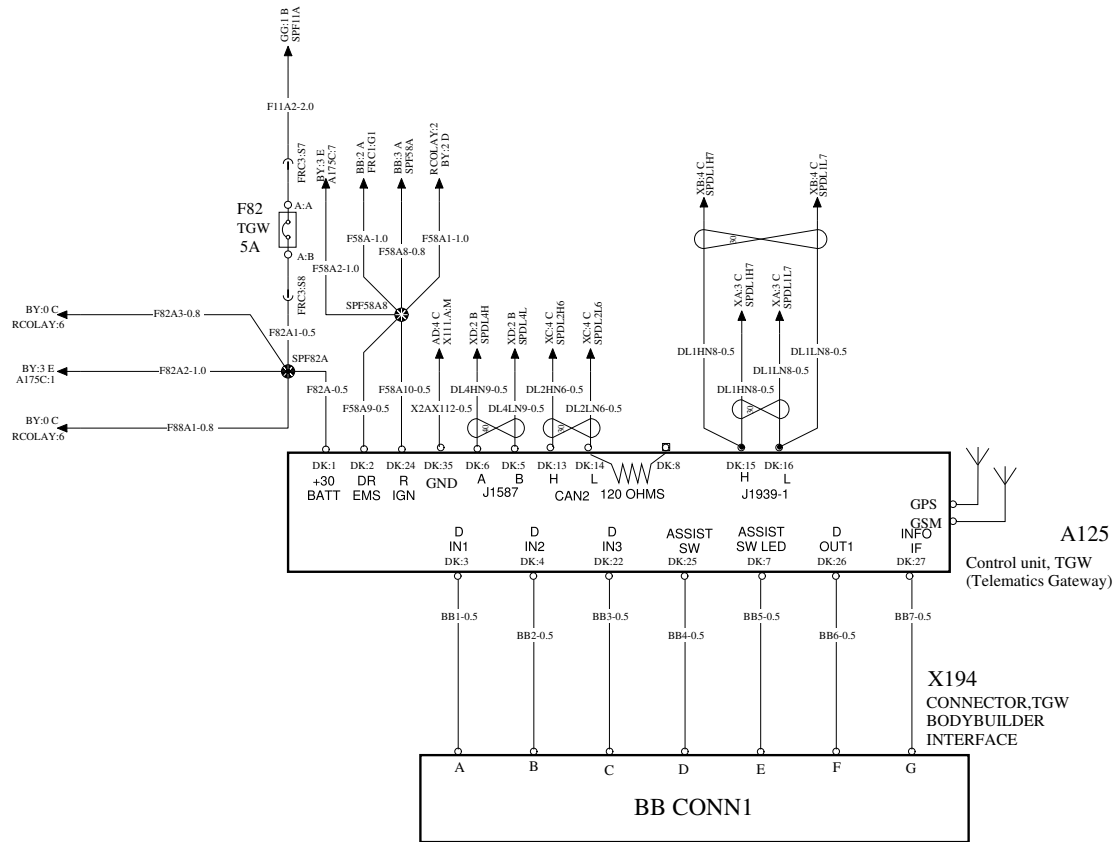
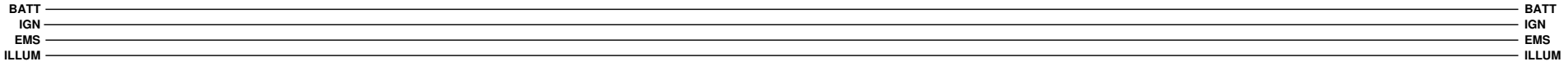

BATT  
EMS

A

A

B

B

C

C

D

D

E

E

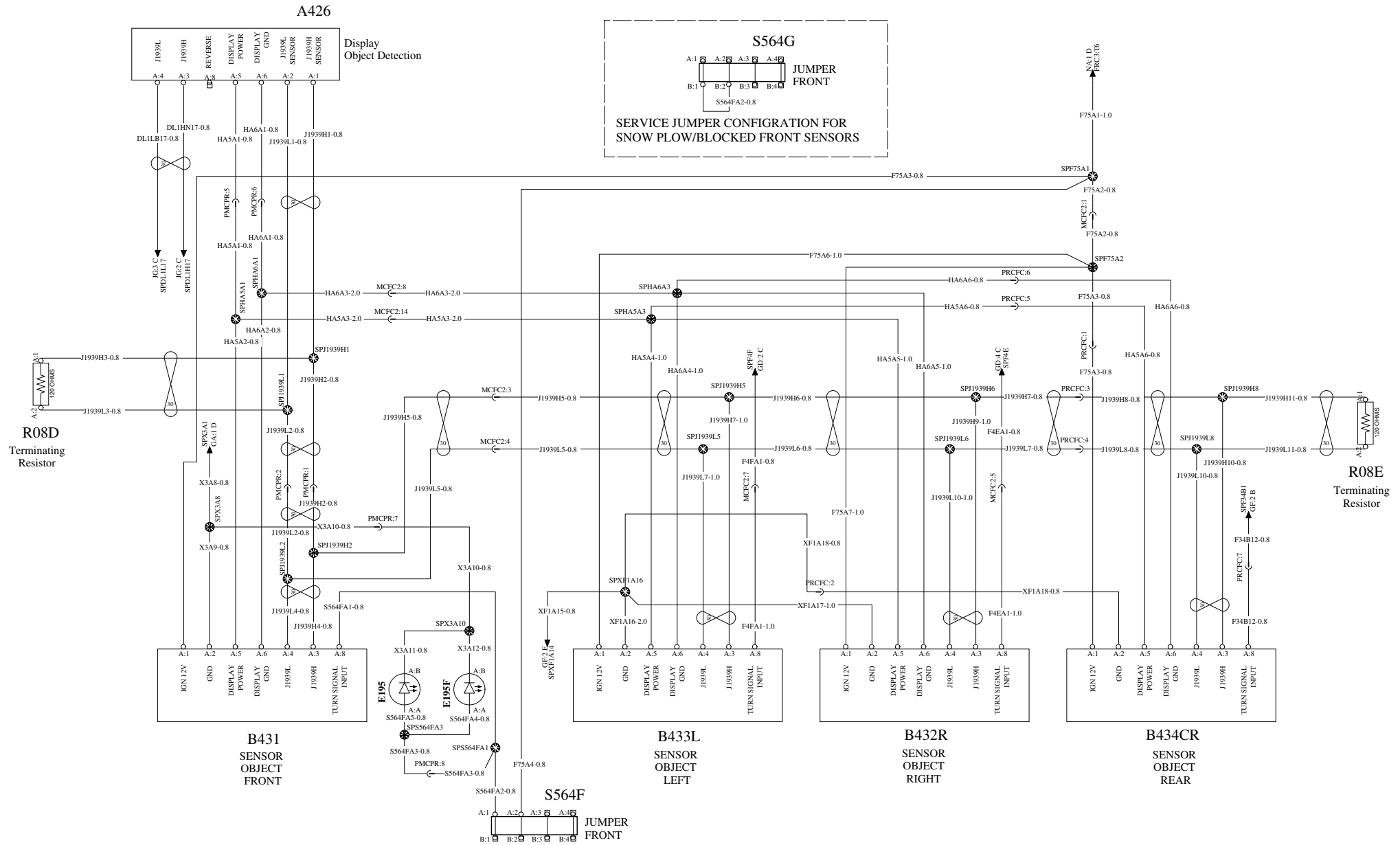

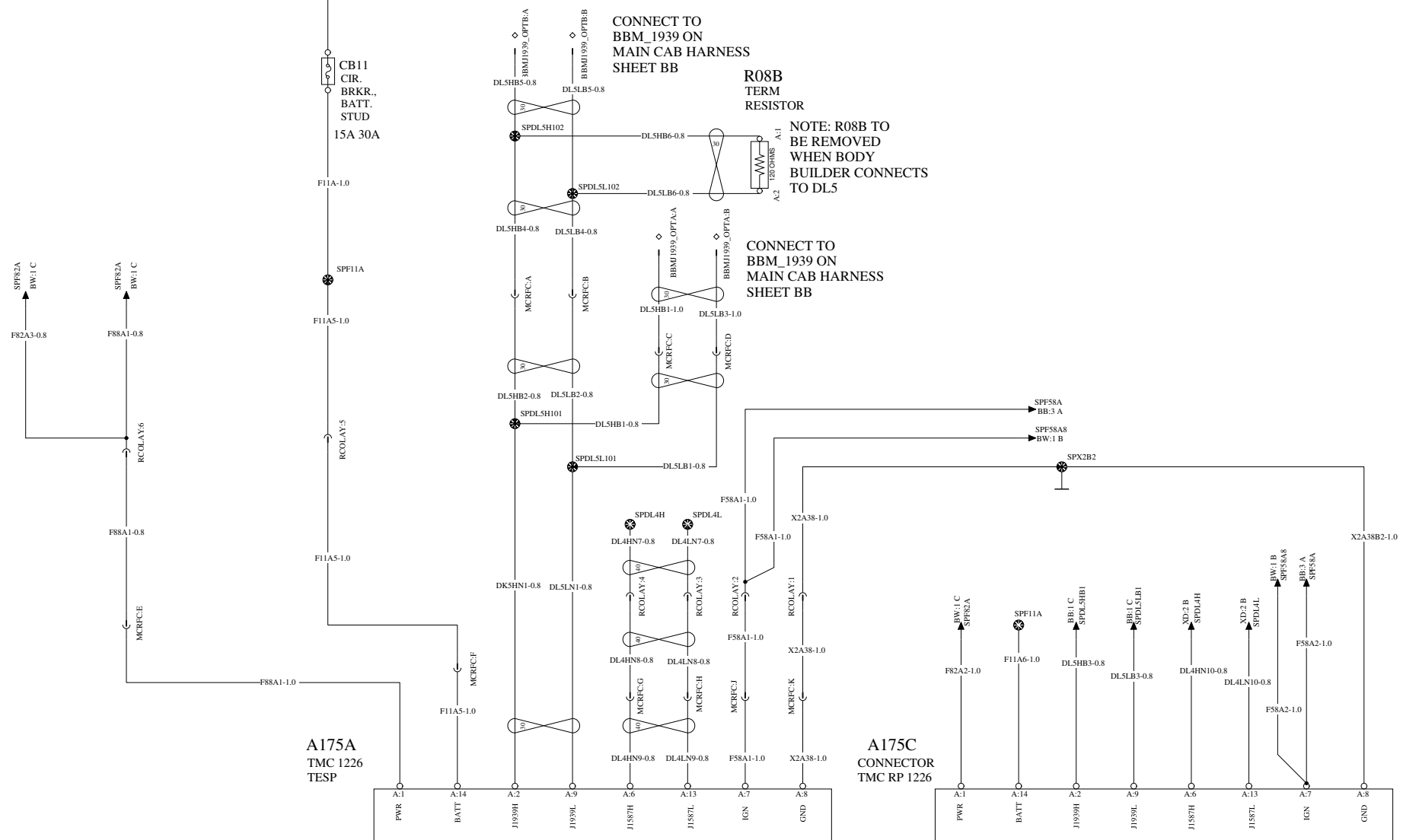
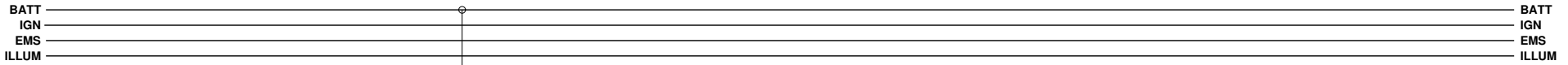

# ENGINE INTERFACE MACK

# WIRING DIAGRAM: CA

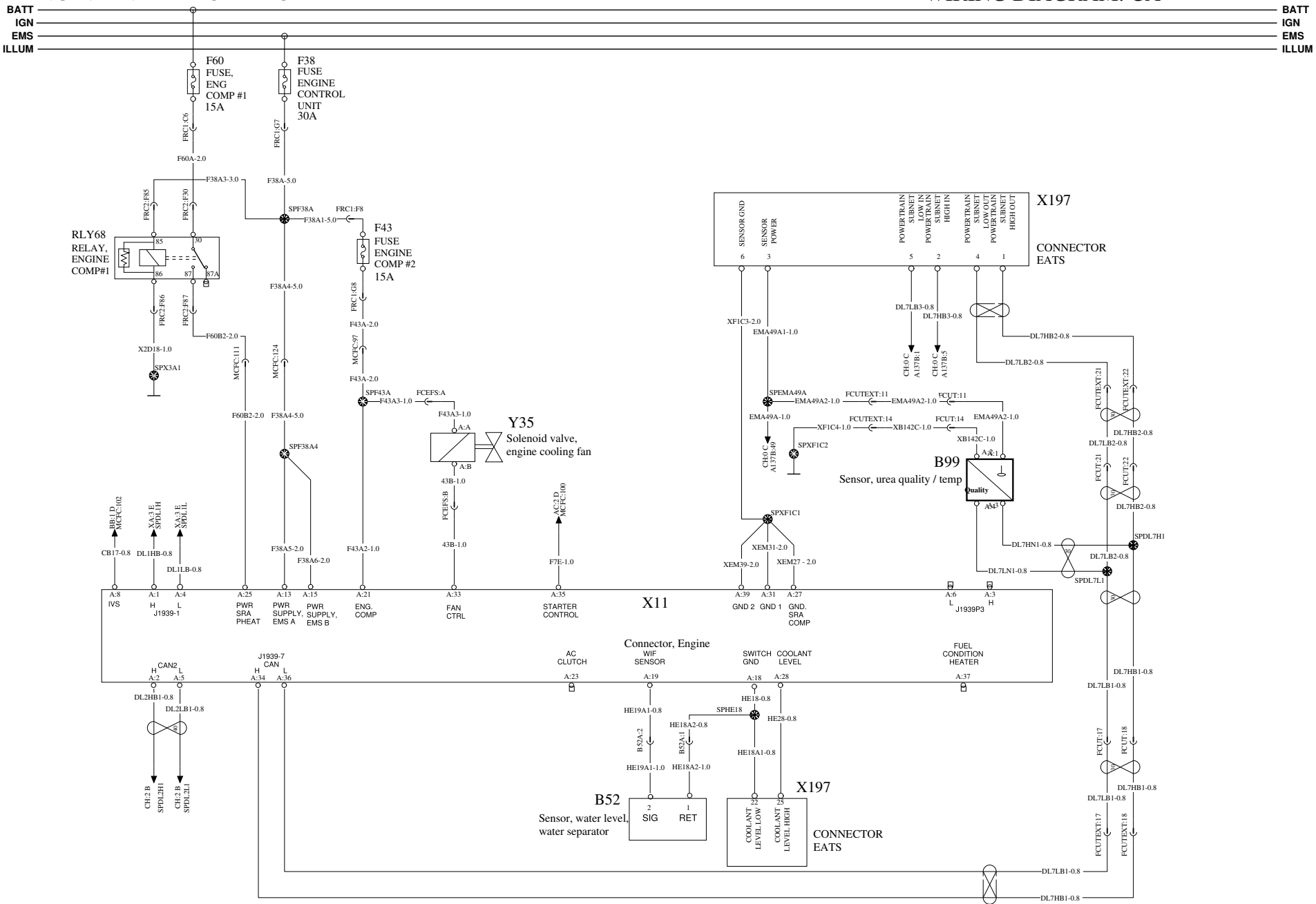

ENGINE HEATER

WIRING DIAGRAM: CC

BATT \_\_\_\_\_ BATT  
 IGN \_\_\_\_\_ IGN  
 EMS \_\_\_\_\_ EMS  
 ILLUM \_\_\_\_\_ ILLUM

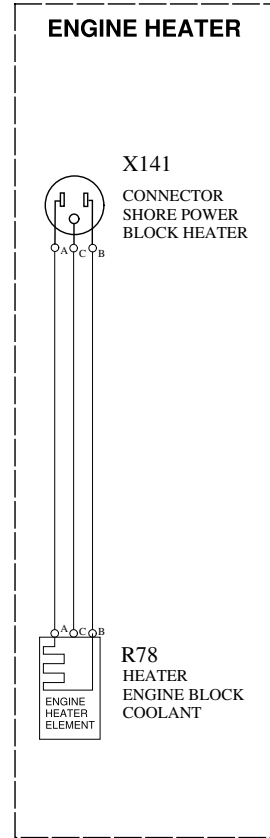
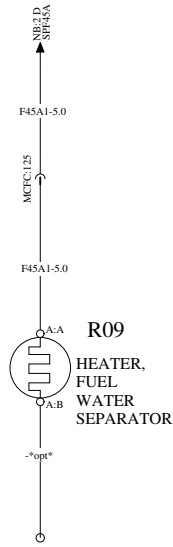

# AUXILIARY COOLING FANS

# WIRING DIAGRAM: CD

BATT  
IGN  
EMS  
ILLUM

BATT  
IGN  
EMS  
ILLUM

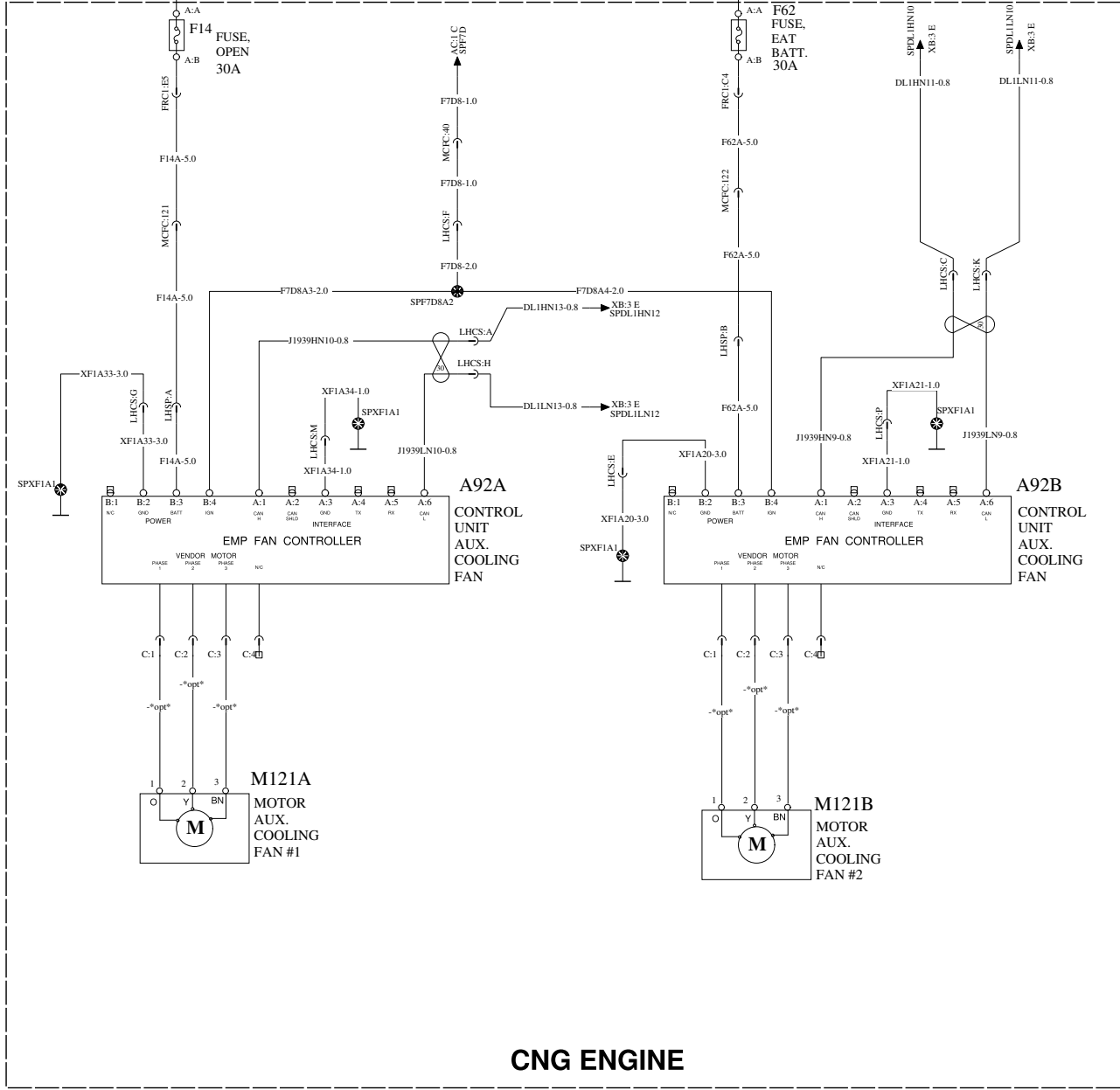
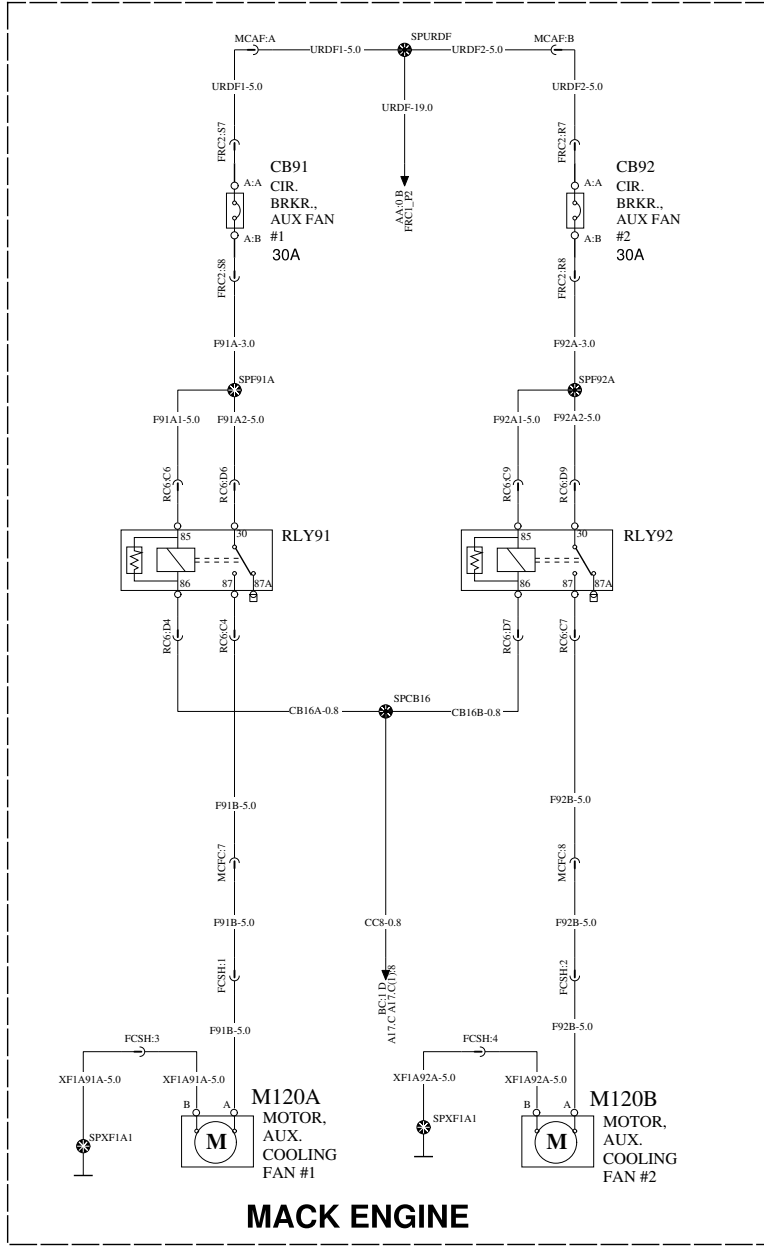

CNG FUEL LEVEL

WIRING DIAGRAM: CG

BATT  
IGN  
EMS  
ILLUM

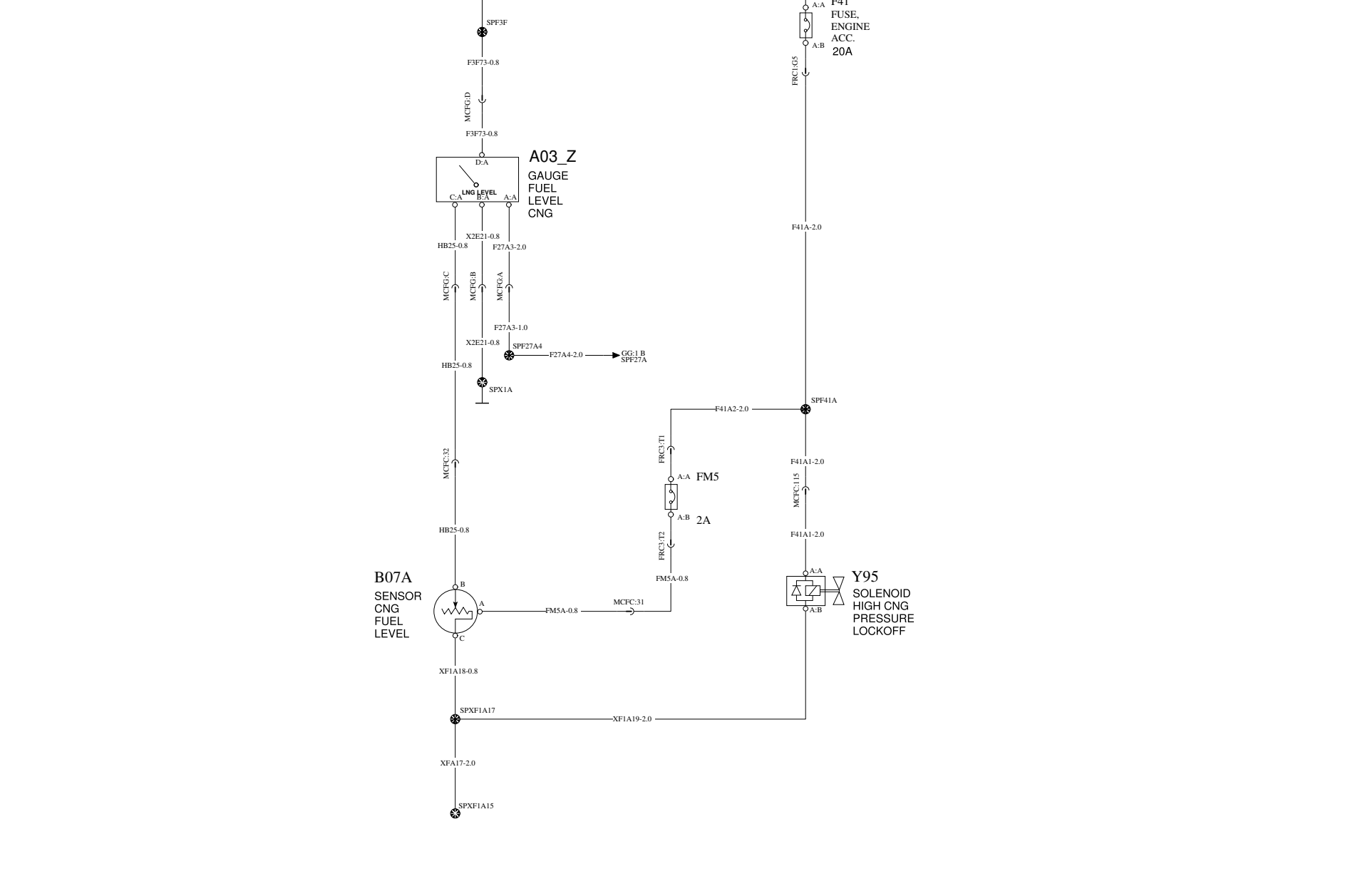

# UREA DOSING SYSTEM

# WIRING DIAGRAM: CH

BATT  
IGN  
EMS  
ILLUM

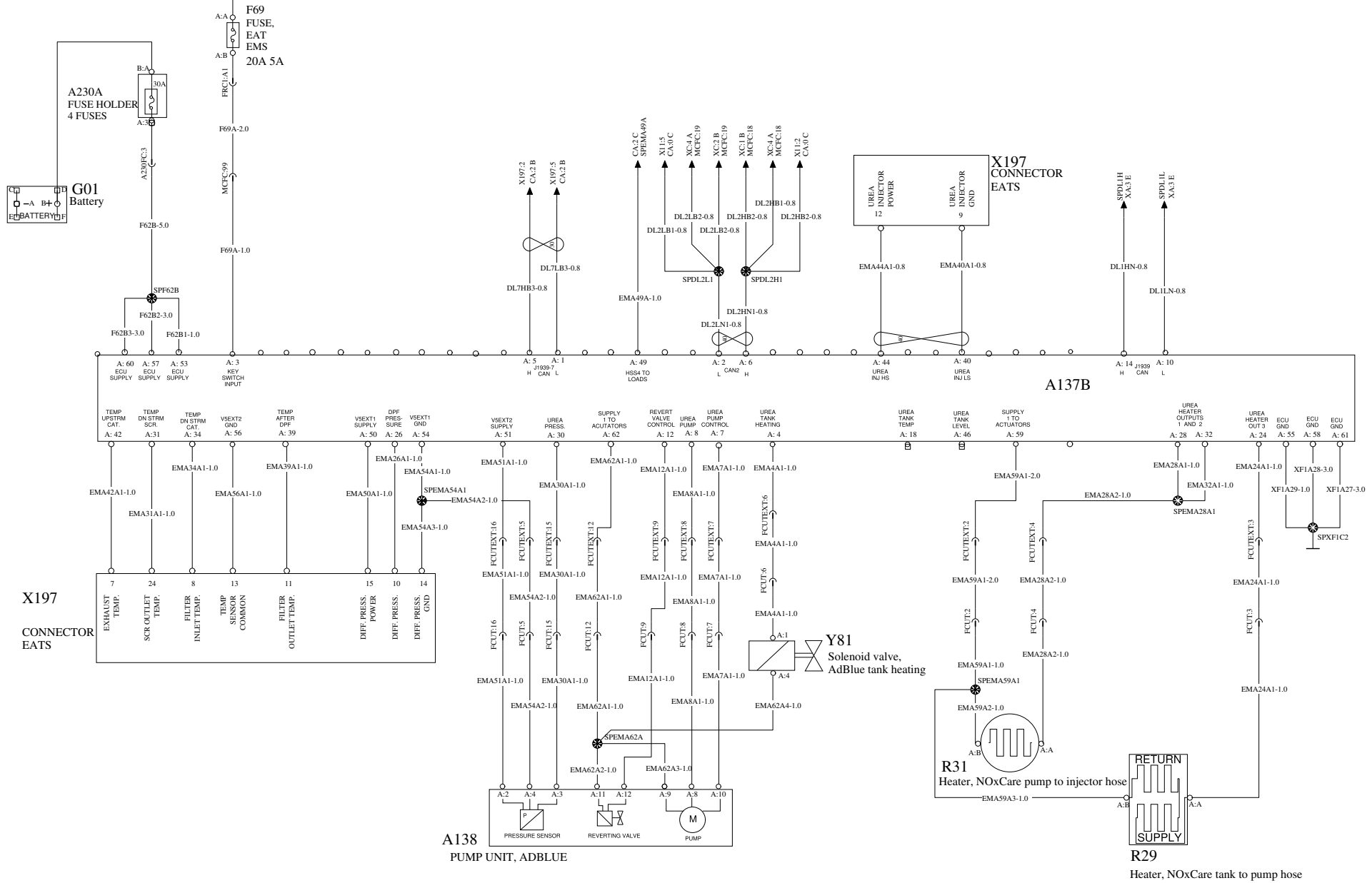



# METHANE DETECTION

# WIRING DIAGRAM: CI

BATT  
IGN  
EMS  
ILLUM

BATT  
IGN  
EMS  
ILLUM

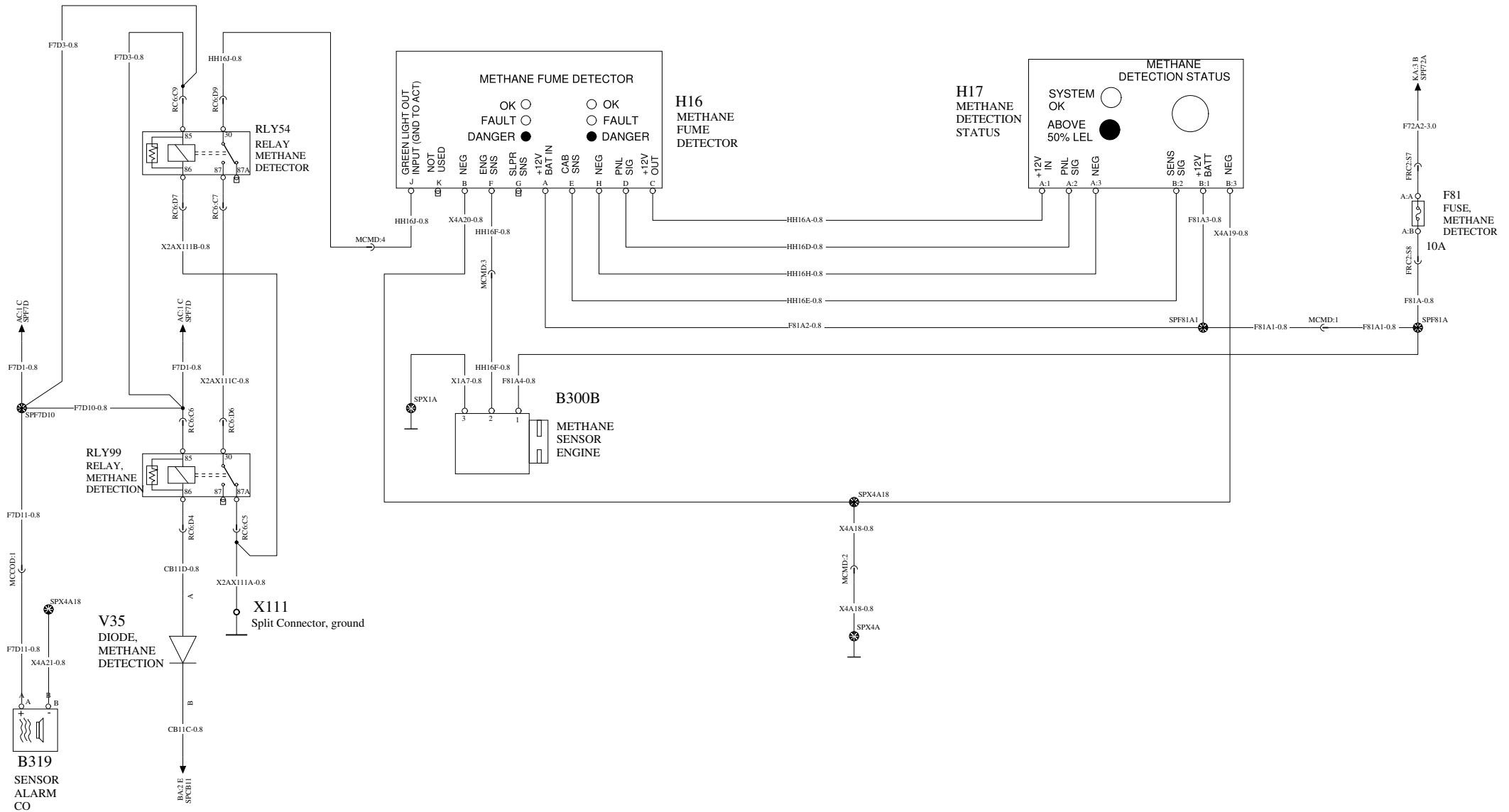

Volvo Truck Corporation

Document title  
WIRING DIAGRAM TYPE OL

Document type  
PRODUCT SCHEMATIC

Document No	Issue	Volume	Page
24403869	01	1 (2)	24 (57)

# ENGINE INTERFACE CUMMINS ISLG OBD 2018

# WIRING DIAGRAM: CJ

BATT  
IGN  
EMS  
ILLUM

BATT  
IGN  
EMS  
ILLUM

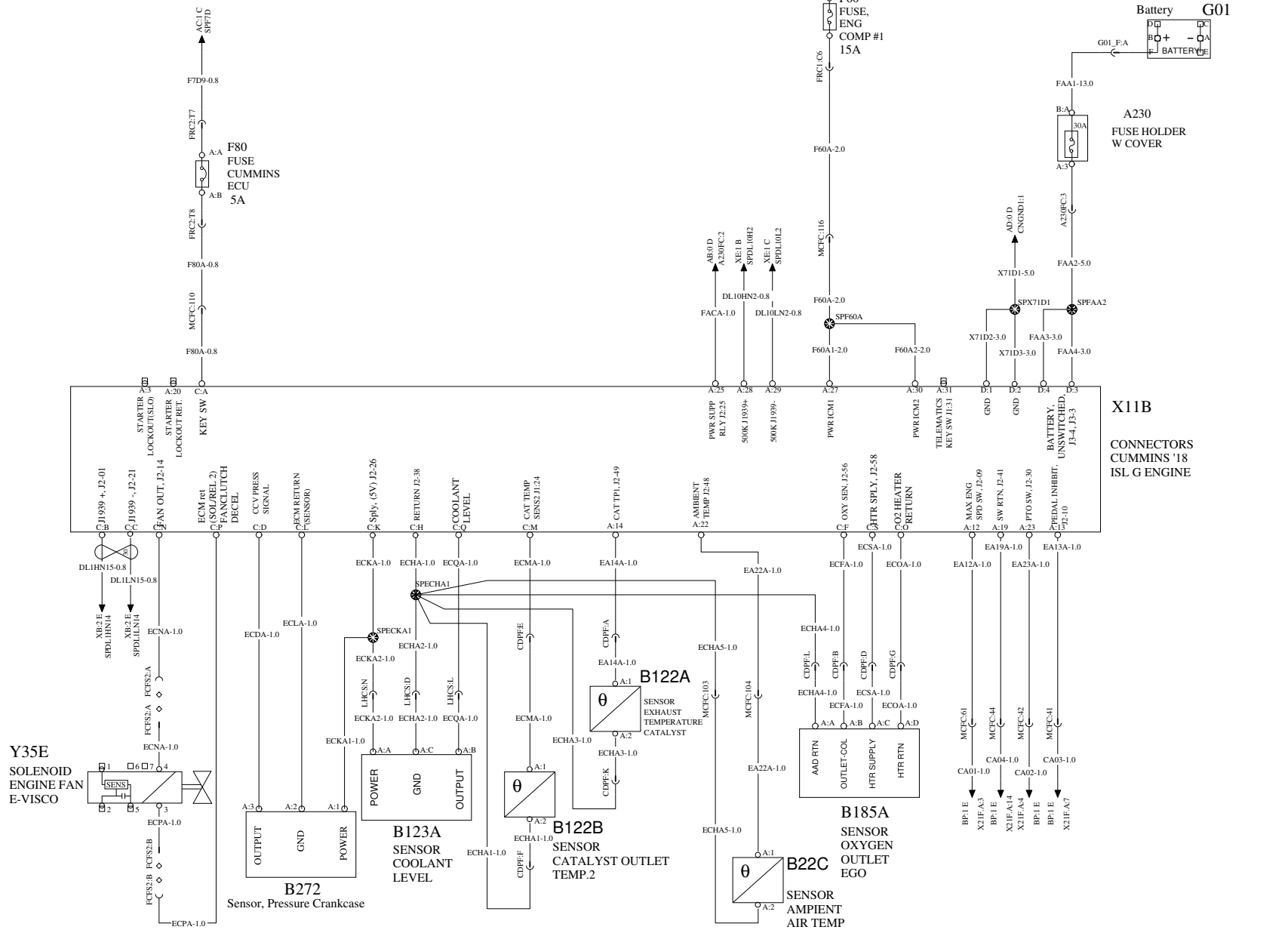

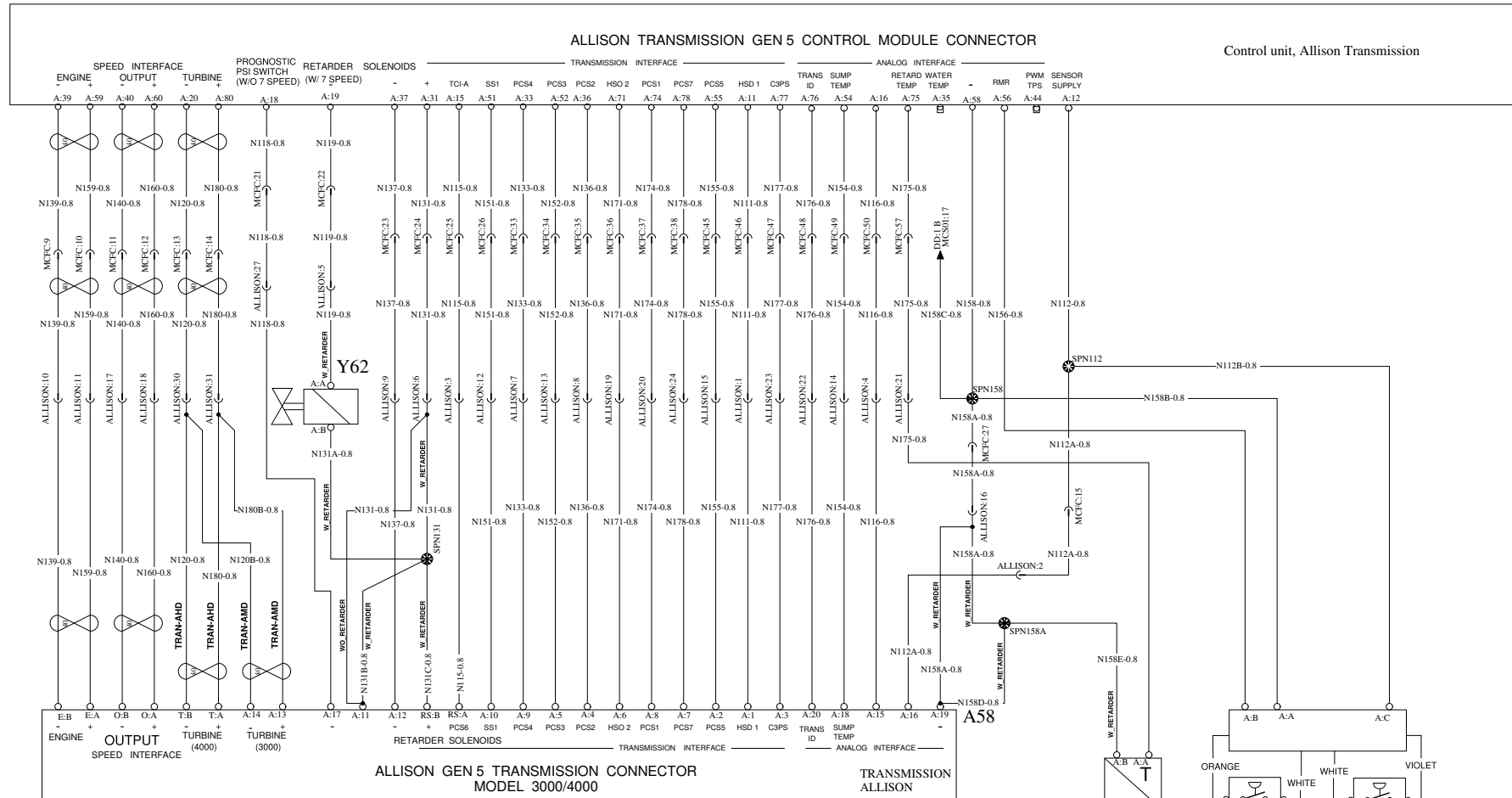
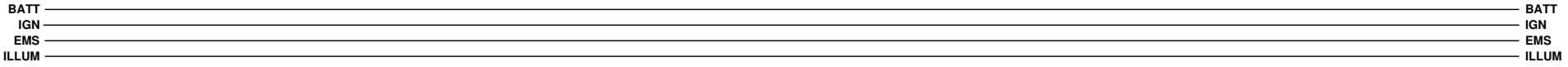

A57

A58

ALLISON GEN 5 TRANSMISSION CONNECTOR MODEL 3000/4000

TRANSMISSION ALLISON

B23A

Sensor, oil temperature, retarder

A99

Component group, transmission and retarder

TRANSMISSION CONTROL 5th GENERATION 2/3

WIRING DIAGRAM: DD

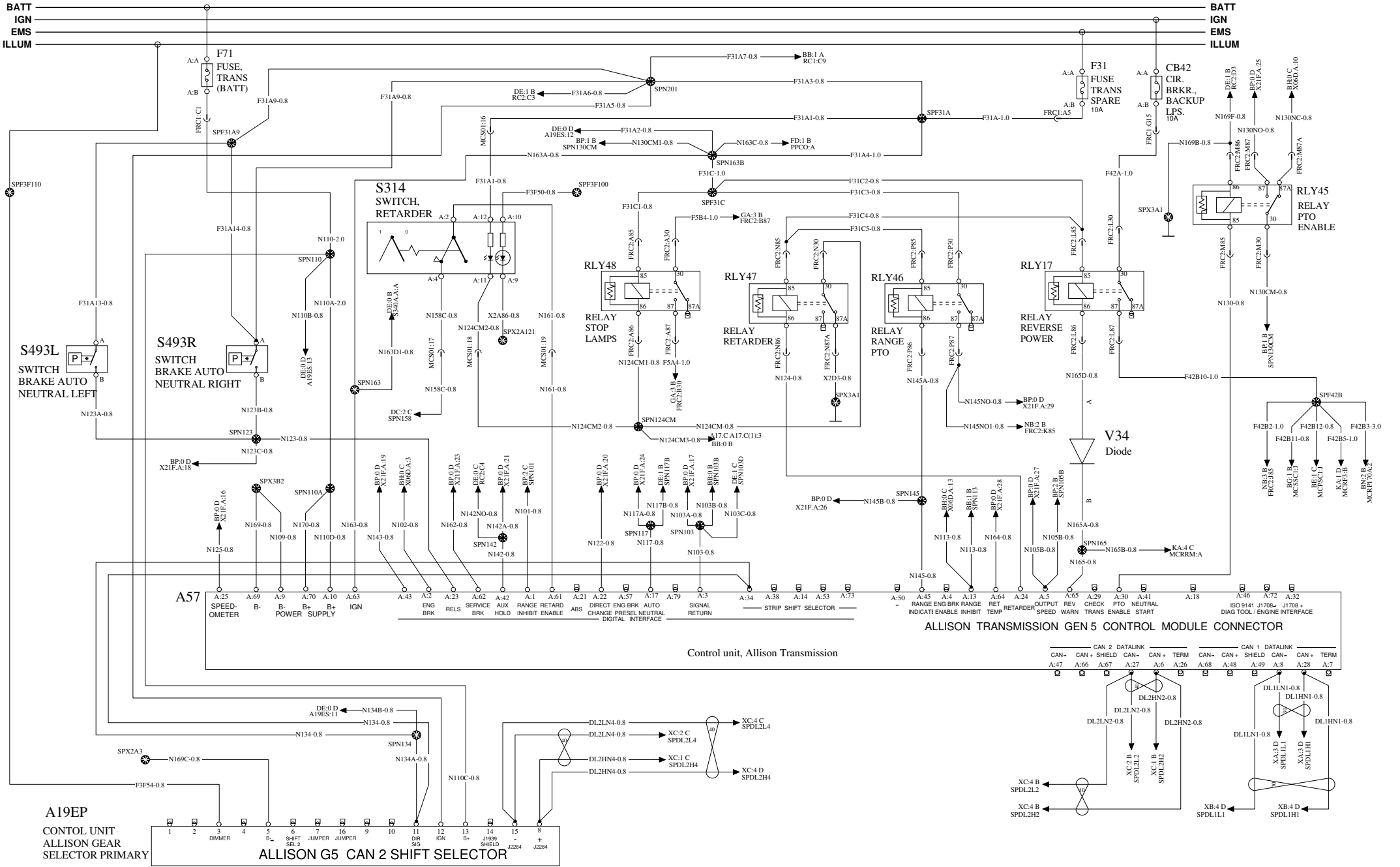

Document title <b>WIRING DIAGRAM TYPE OL</b>	Document No	Issue	Volume	Page
	Document type <b>PRODUCT SCHEMATIC</b>	<b>24403869</b>	<b>01</b>	<b>1 (2) 27 (57)</b>

TRANSMISSION CONTROL 5th GENERATION 3/3

WIRING DIAGRAM: DE

BATT  
IGN  
EMS  
ILLUM

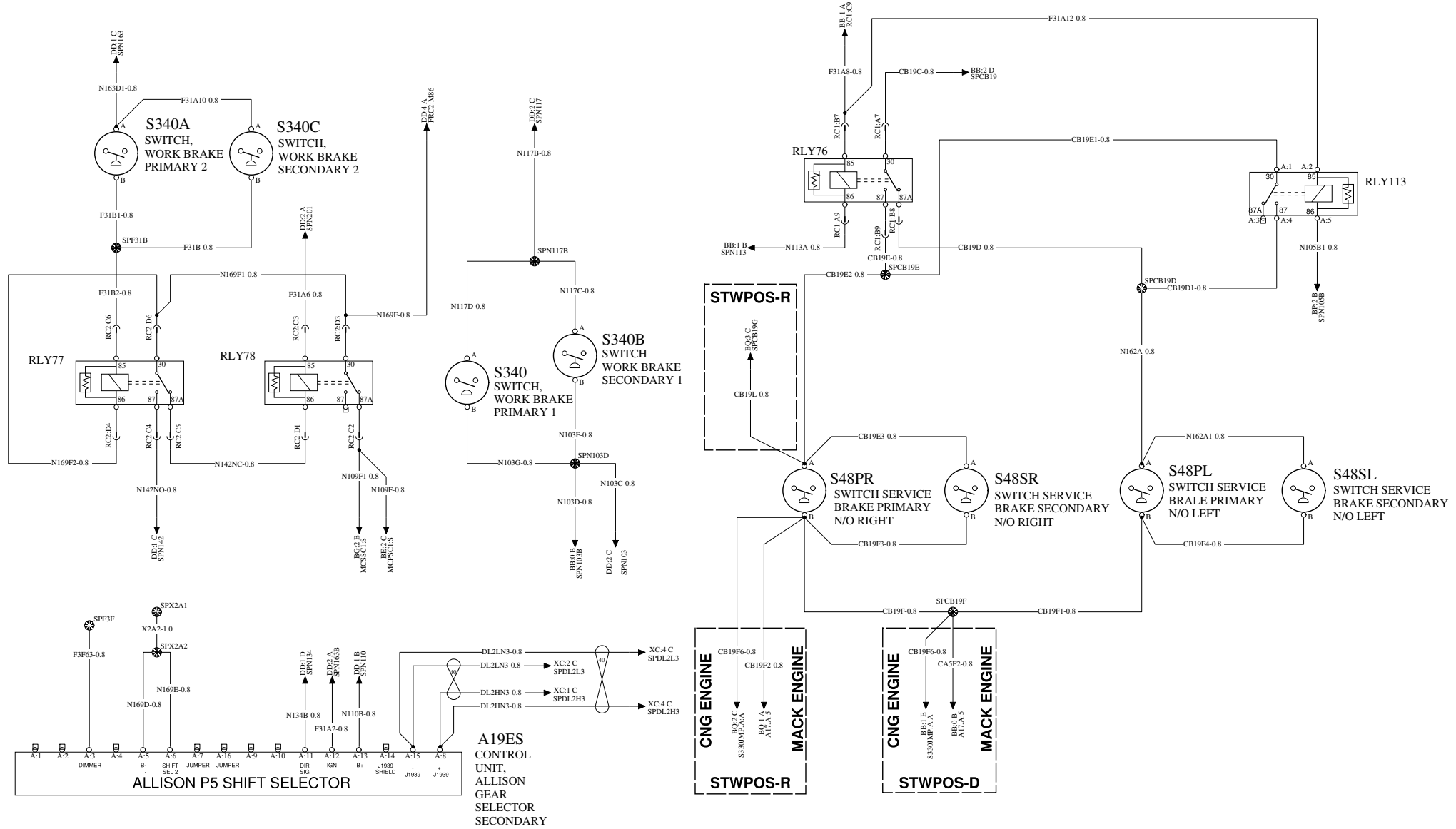

ABS - MERITOR

WIRING DIAGRAM: EA

BATT  
IGN  
EMS  
ILLUM

BATT  
IGN  
EMS  
ILLUM

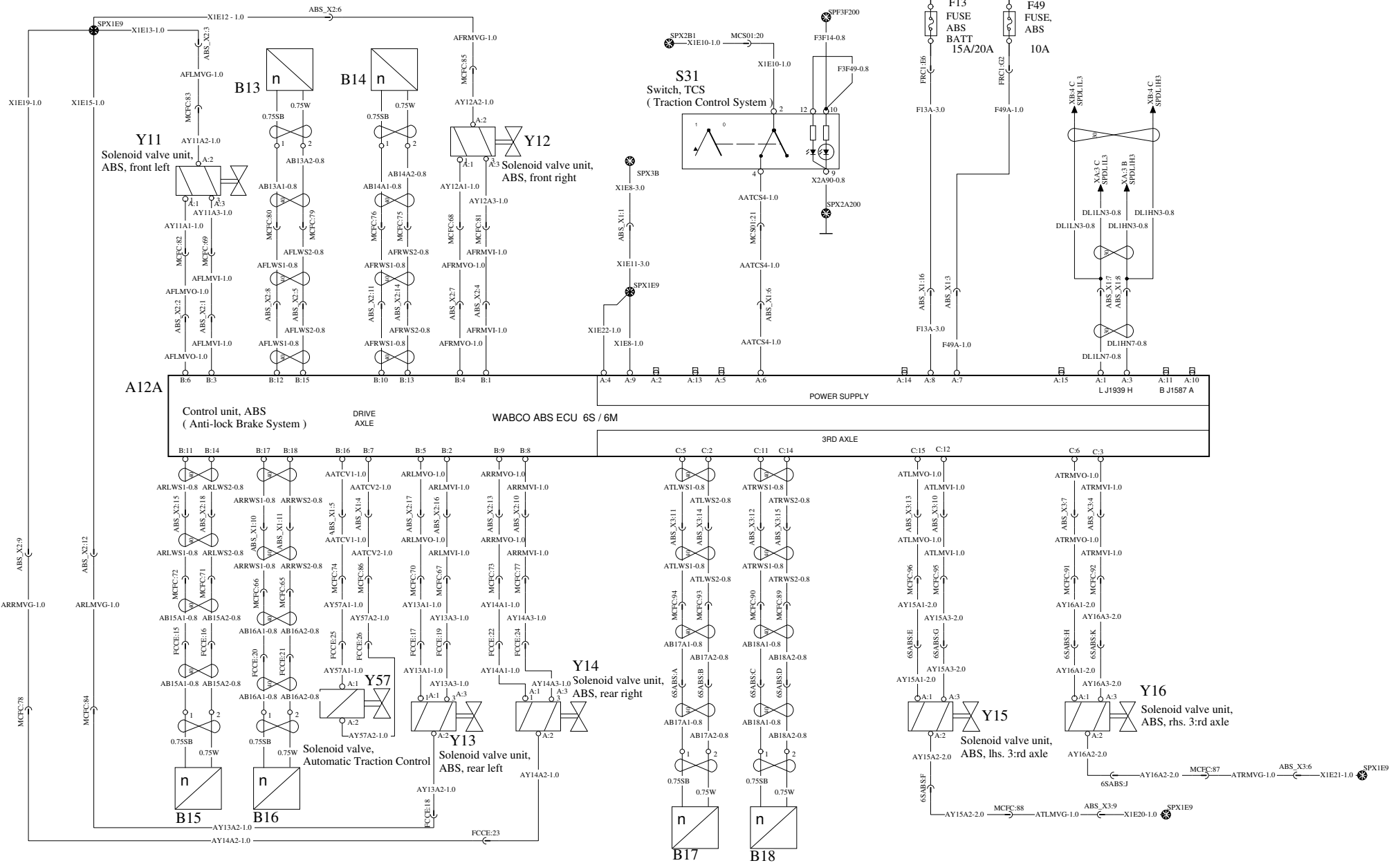

Volvo Truck Corporation

Document title  
WIRING DIAGRAM TYPE OL

Document type  
PRODUCT SCHEMATIC

Document No	Issue	Volume	Page
24403869	01	1 (2)	29 (57)

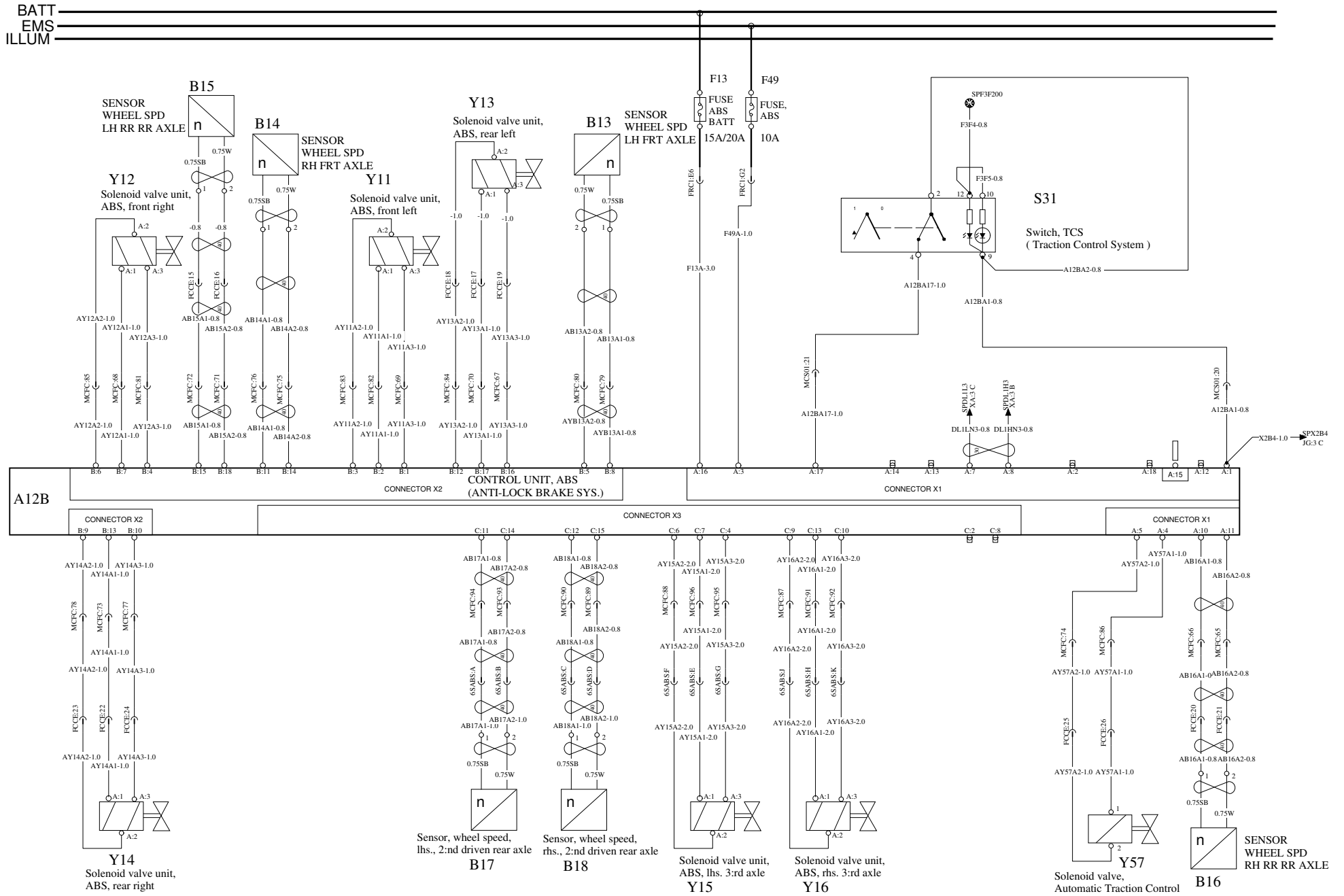

A12B  
CONTROL UNIT, ABS  
(ANTI-LOCK BRAKE SYS.)

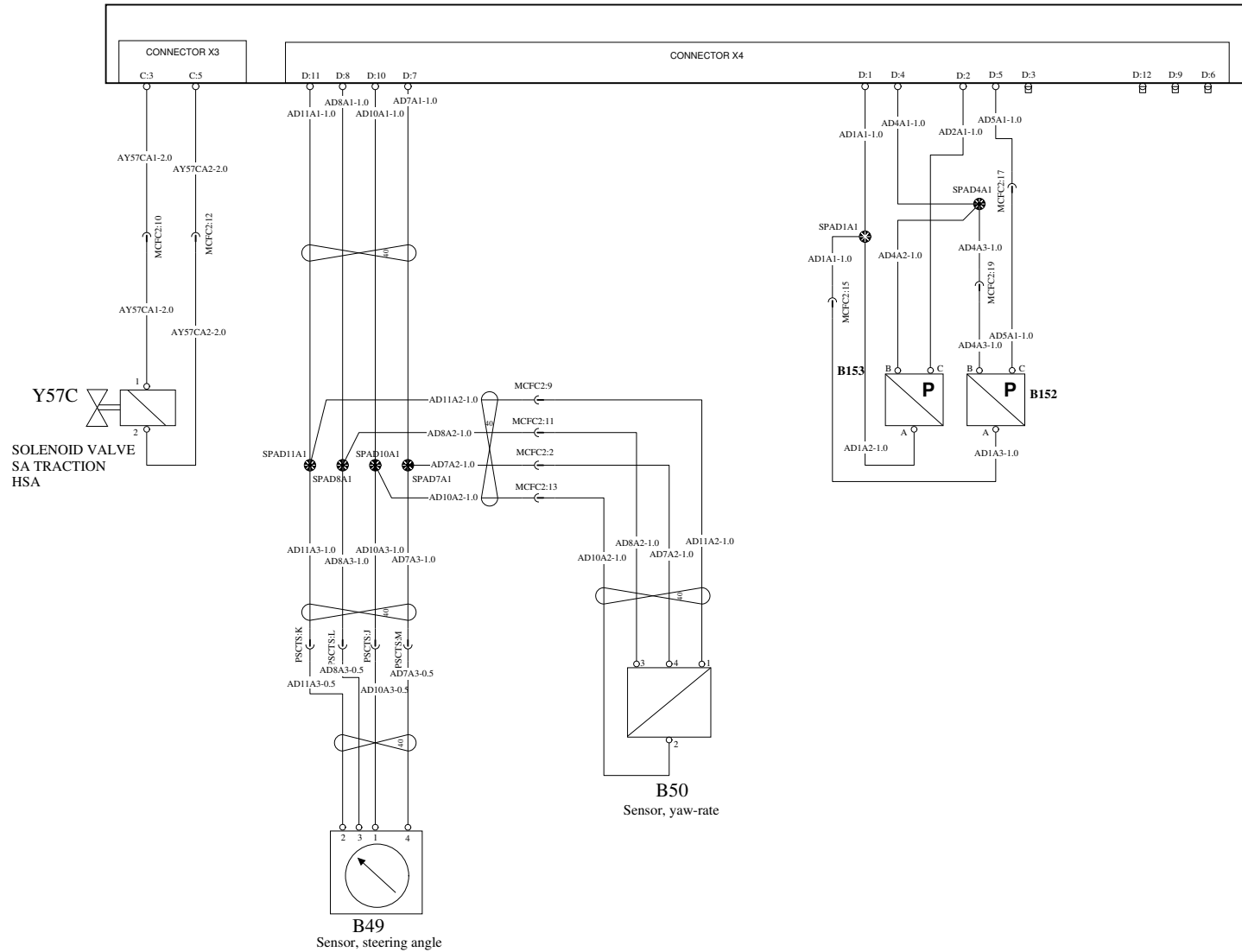



AIR DRYER/HEATED DRAIN

WIRING DIAGRAM: FA

BATT  
IGN  
EMS  
ILLUM

BATT  
IGN  
EMS  
ILLUM

CB44  
CIR.  
BRKR.,  
HTD. AIR DRYER  
/HTD. DRAIN  
VALVE  
25A

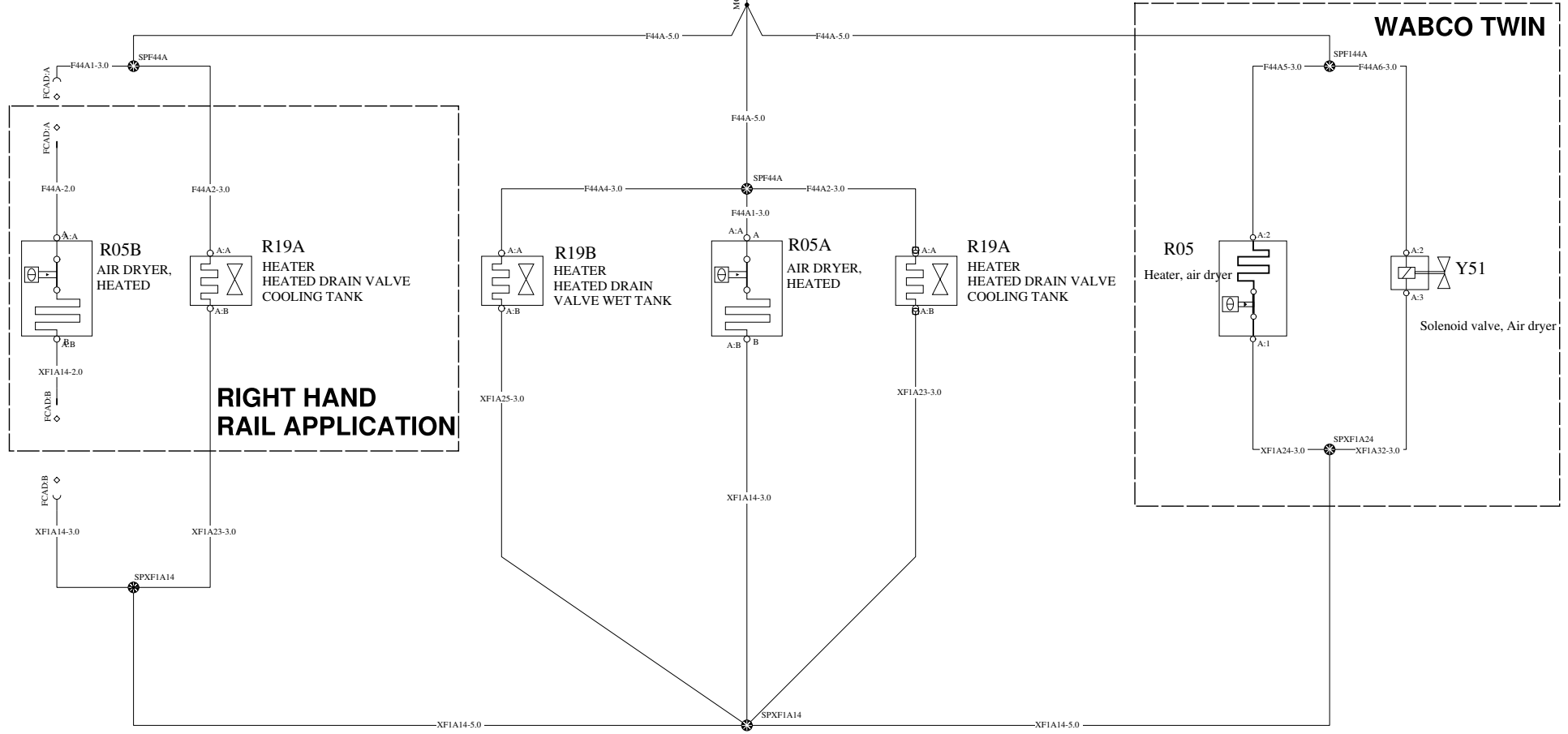

**RIGHT HAND  
RAIL APPLICATION**

**WABCO TWIN**

**Air Dryer, Cooling Tank  
Heated Drain Valve, and  
Wet Tank Heated Drain Valve**

Volvo Truck Corporation

Document title WIRING DIAGRAM TYPE OL	Document No 24403869	Issue 01	Volume 1 (2)	Page 32 (57)
Document type PRODUCT SCHEMATIC				

# CHASSIS SOLENOIDS

# WIRING DIAGRAM: FB

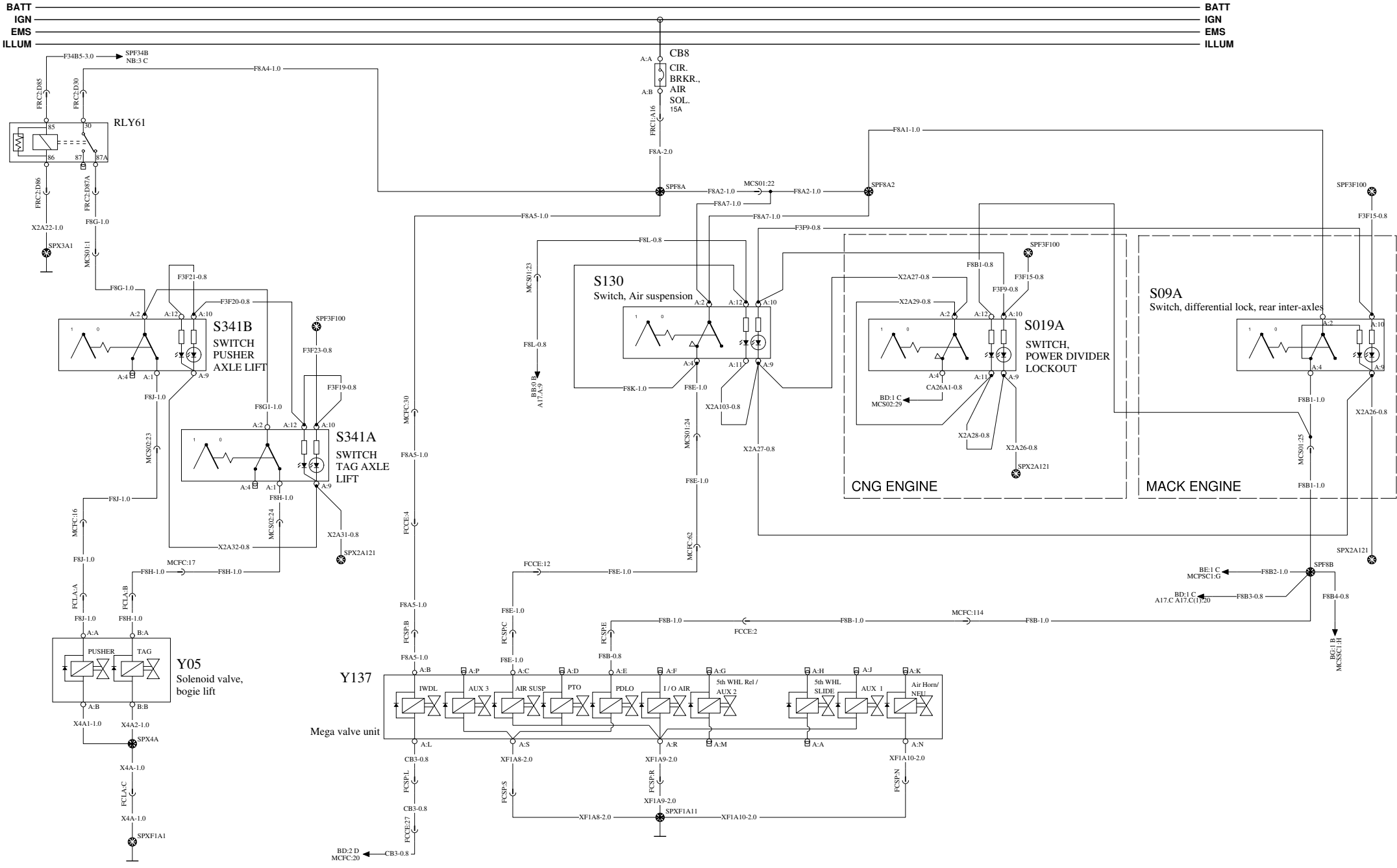

# MUNCIE PUMP, BEACON LAMPS & WORKBRAKE SOLENOID

# WIRING DIAGRAM: FC

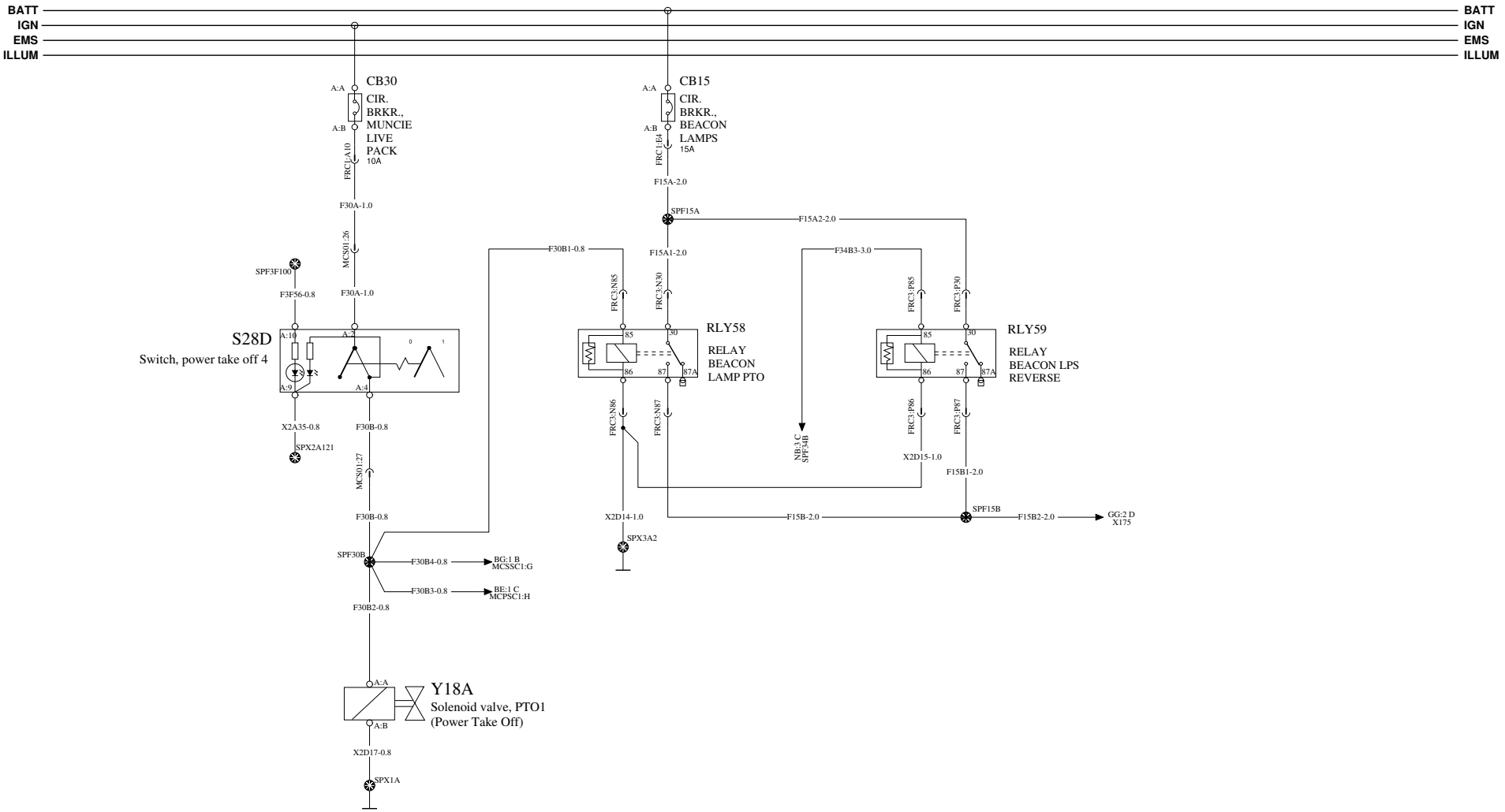

PARKER PTO

WIRING DIAGRAM: FD

BATT  
IGN  
EMS  
ILLUM

BATT  
IGN  
EMS  
ILLUM

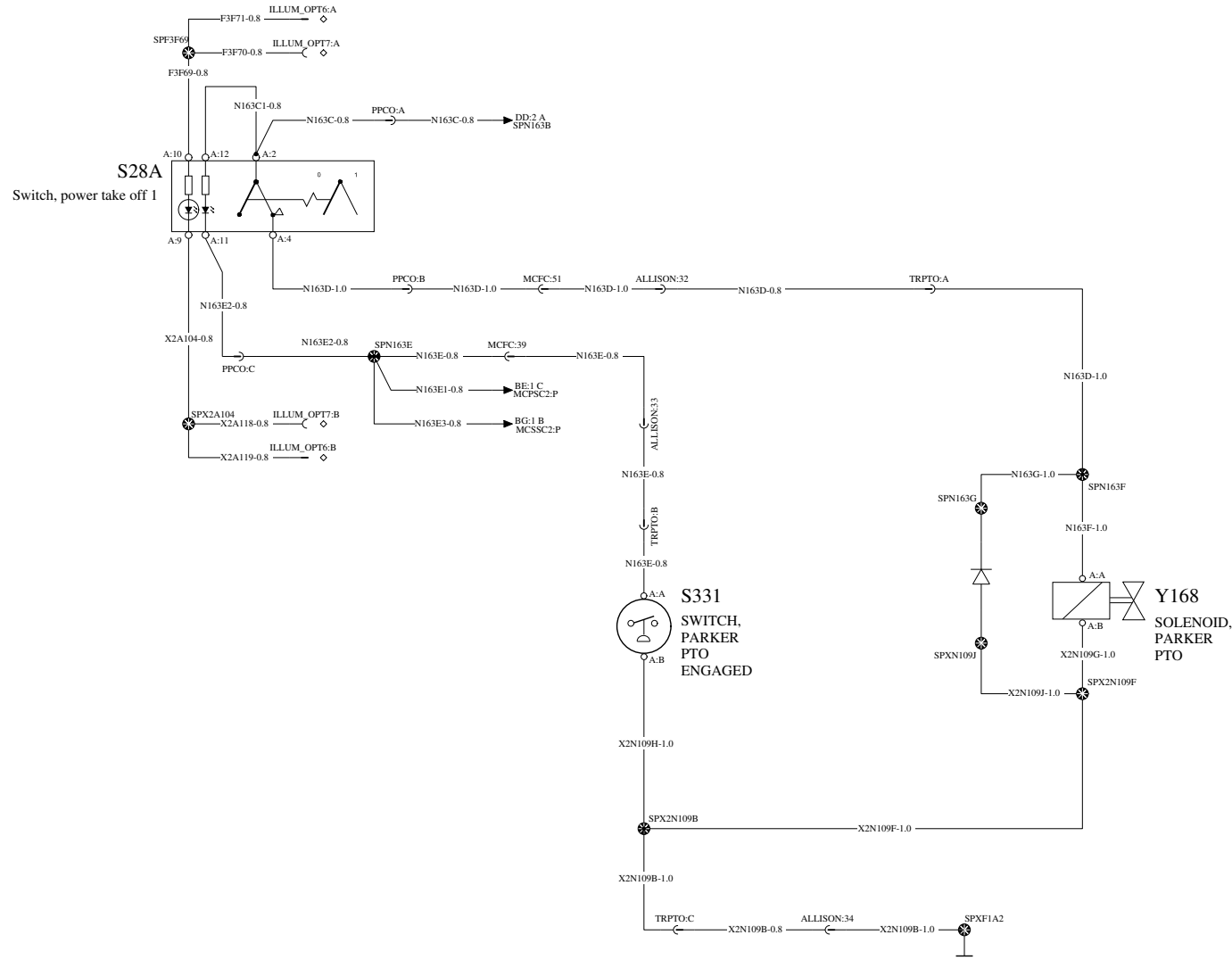

LIGHTING - CONTROLS

WIRING DIAGRAM: GA

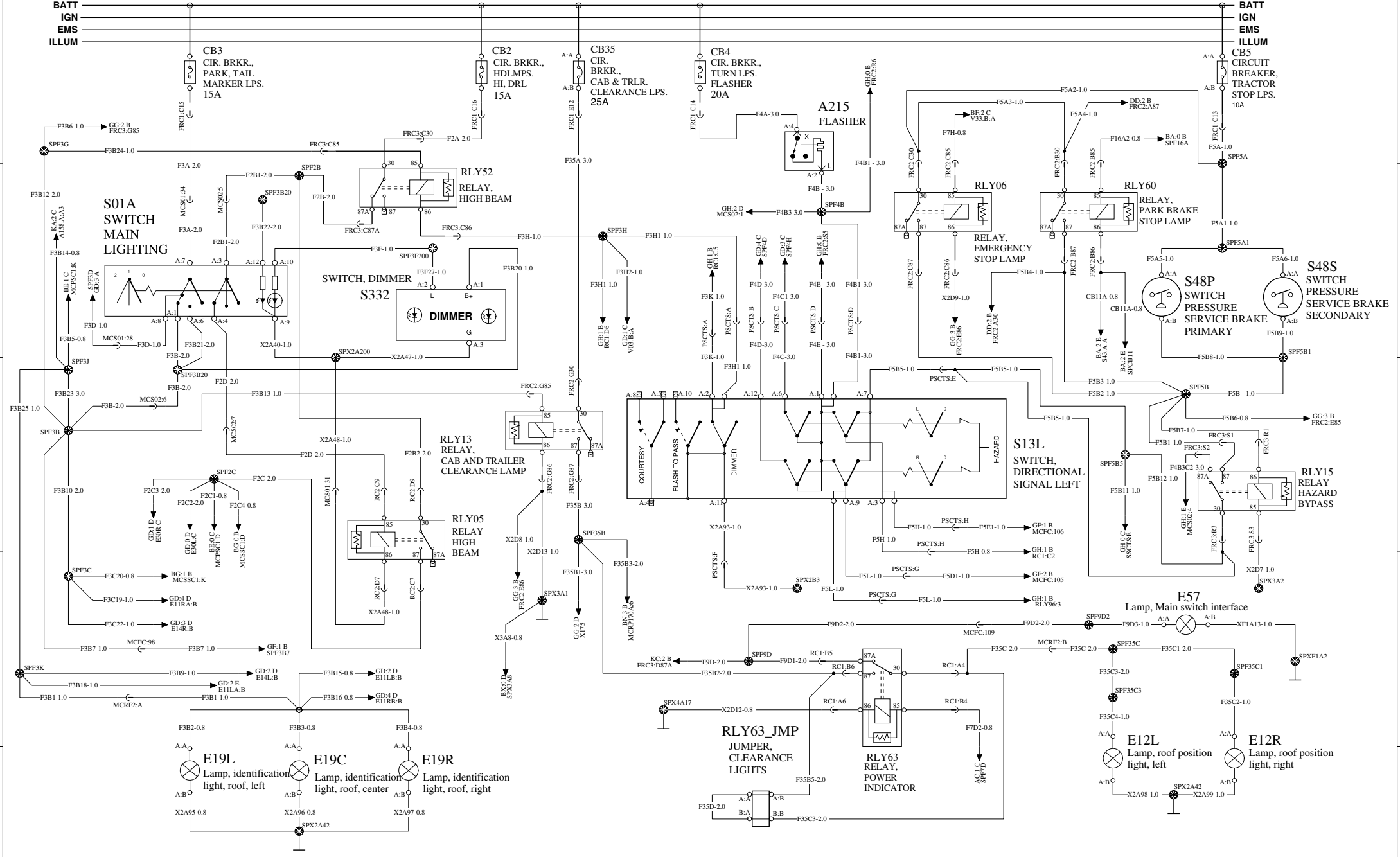

LIGHTING - FORWARD/SIGNAL

WIRING DIAGRAM: GD

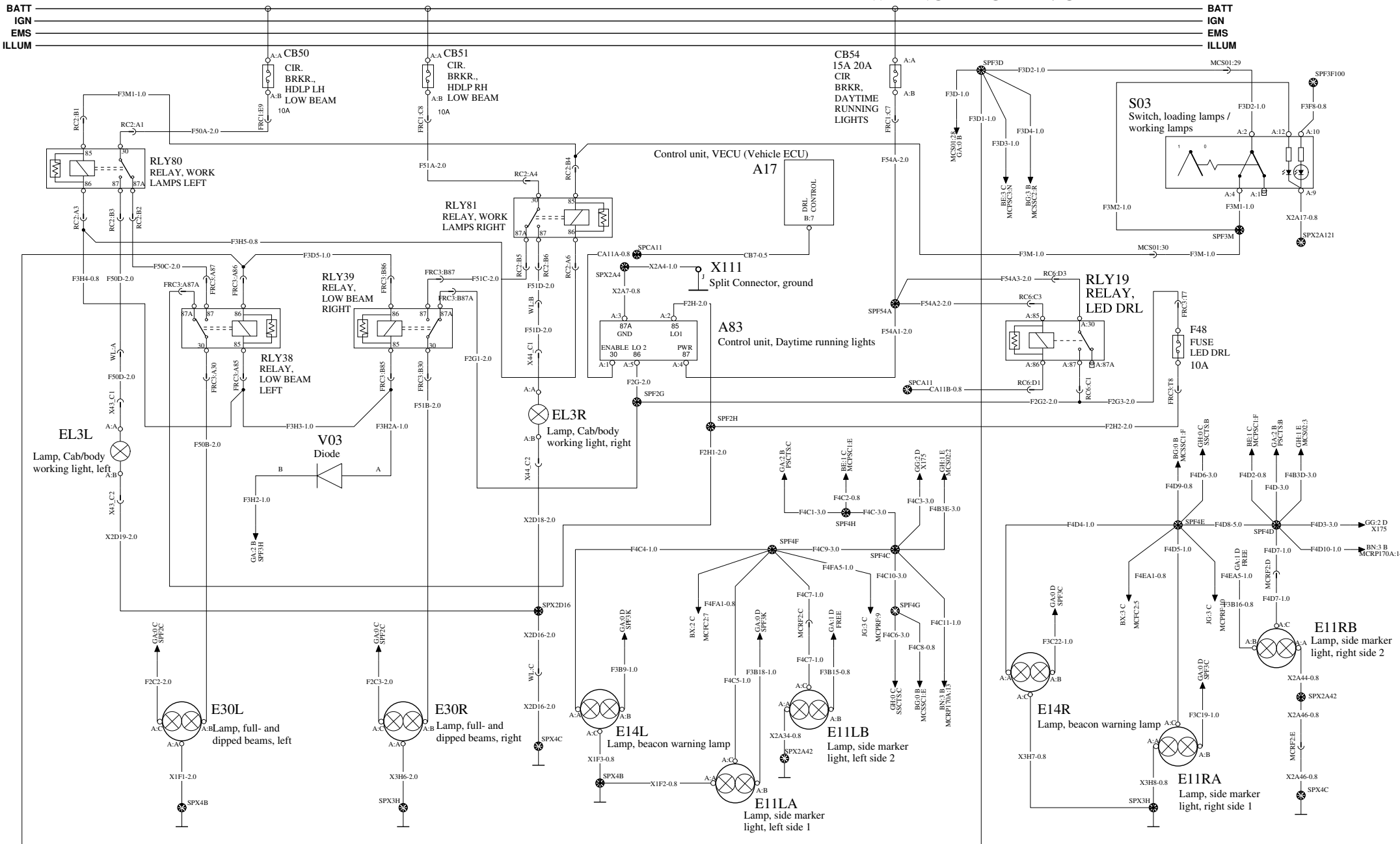

LIGHTING - TAIL LAMP

WIRING DIAGRAM:GF

BATT \_\_\_\_\_ BATT  
 IGN \_\_\_\_\_ IGN  
 EMS \_\_\_\_\_ EMS  
 ILLUM \_\_\_\_\_ ILLUM

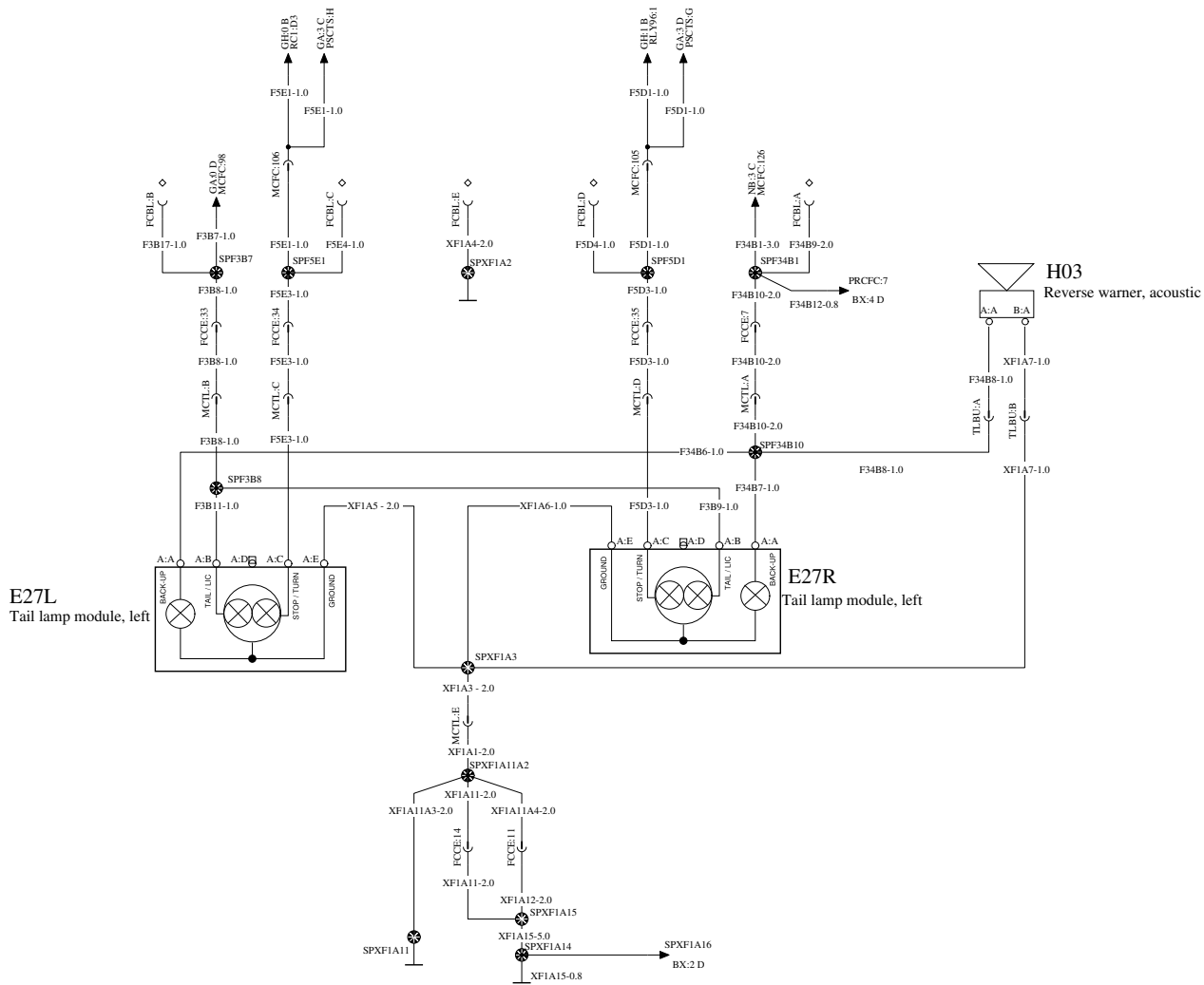

A

B

C

D

E

A

B

C

D

E

LIGHTING - TRAILER CONTROL

WIRING DIAGRAM: GG

BATT  
IGN  
EMS  
ILLUM

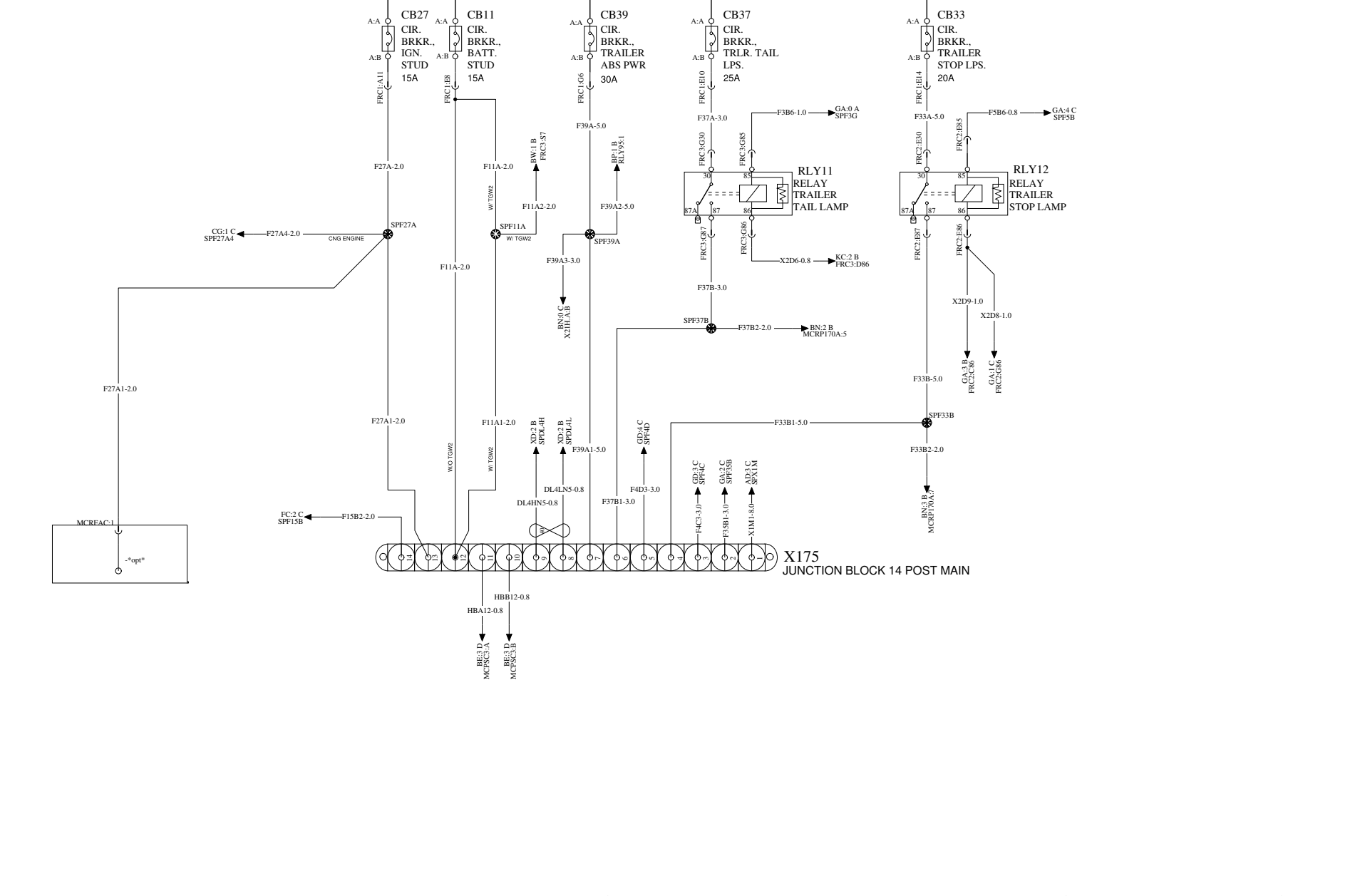

Volvo Truck Corporation

Document title WIRING DIAGRAM TYPE OL	Document No <b>24403869</b>	Issue 01	Volume 1 (2)	Page 39 (57)
Document type PRODUCT SCHEMATIC				



# LIGHTING - LH/RH CONTROL & INTERIOR

# WIRING DIAGRAM: GH

BATT  
IGN  
EMS  
ILLUM

BATT  
IGN  
EMS  
ILLUM

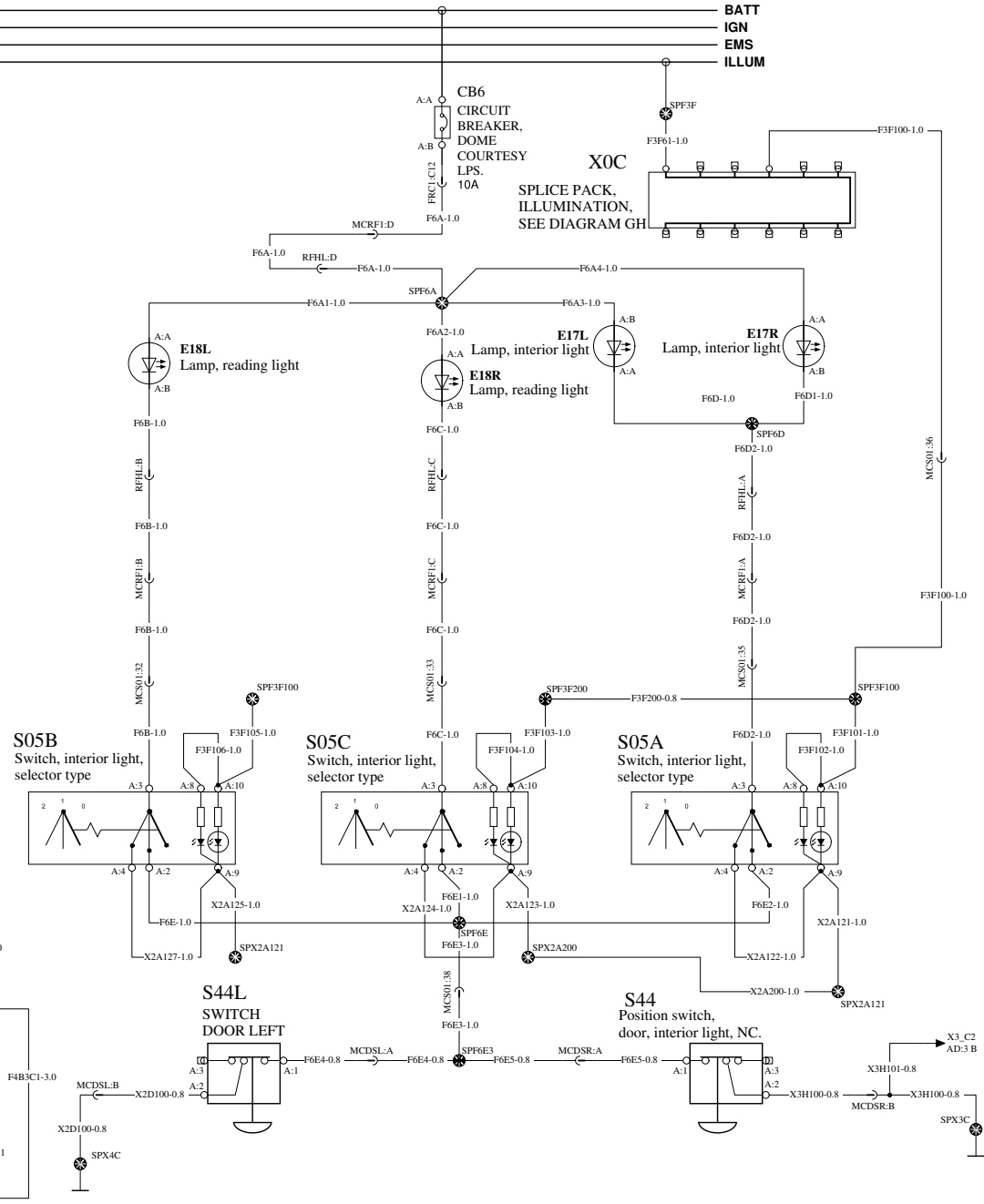
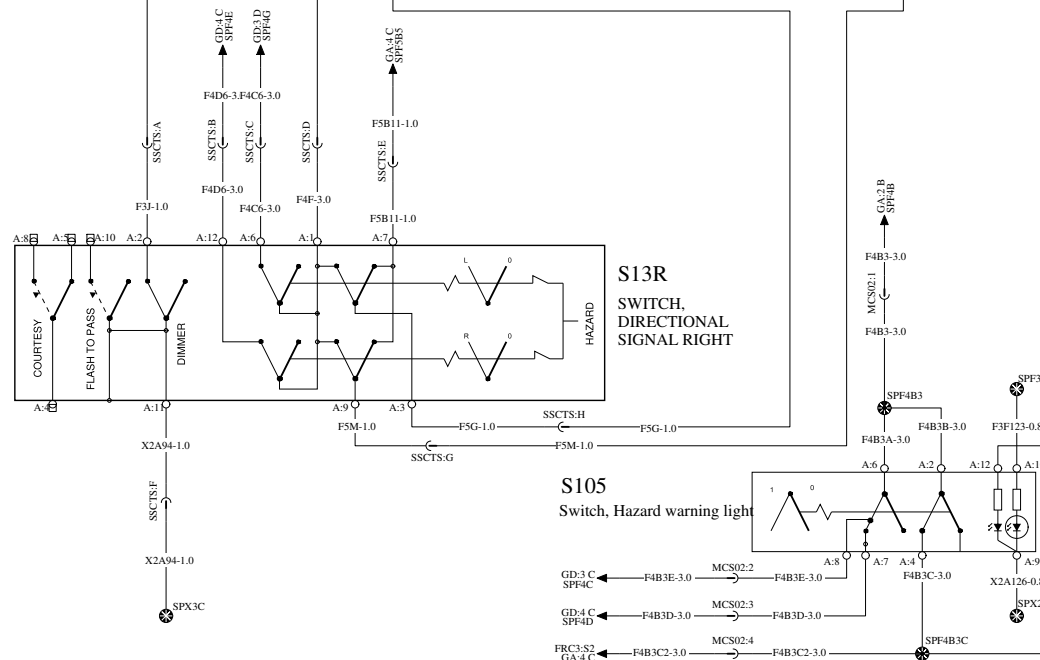
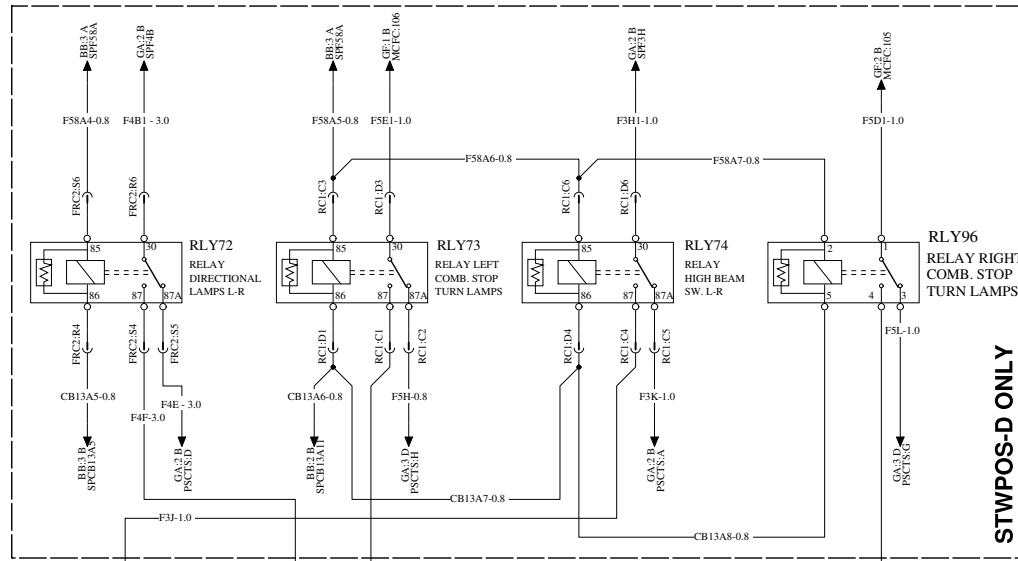

Volvo Truck Corporation

Document title  
WIRING DIAGRAM TYPE OL  
Document type  
PRODUCT SCHEMATIC

Document No	Issue	Volume	Page
24403869	01	1 (2)	40 (57)

# WINDSHIELD WASHER

# WIRING DIAGRAM: GP

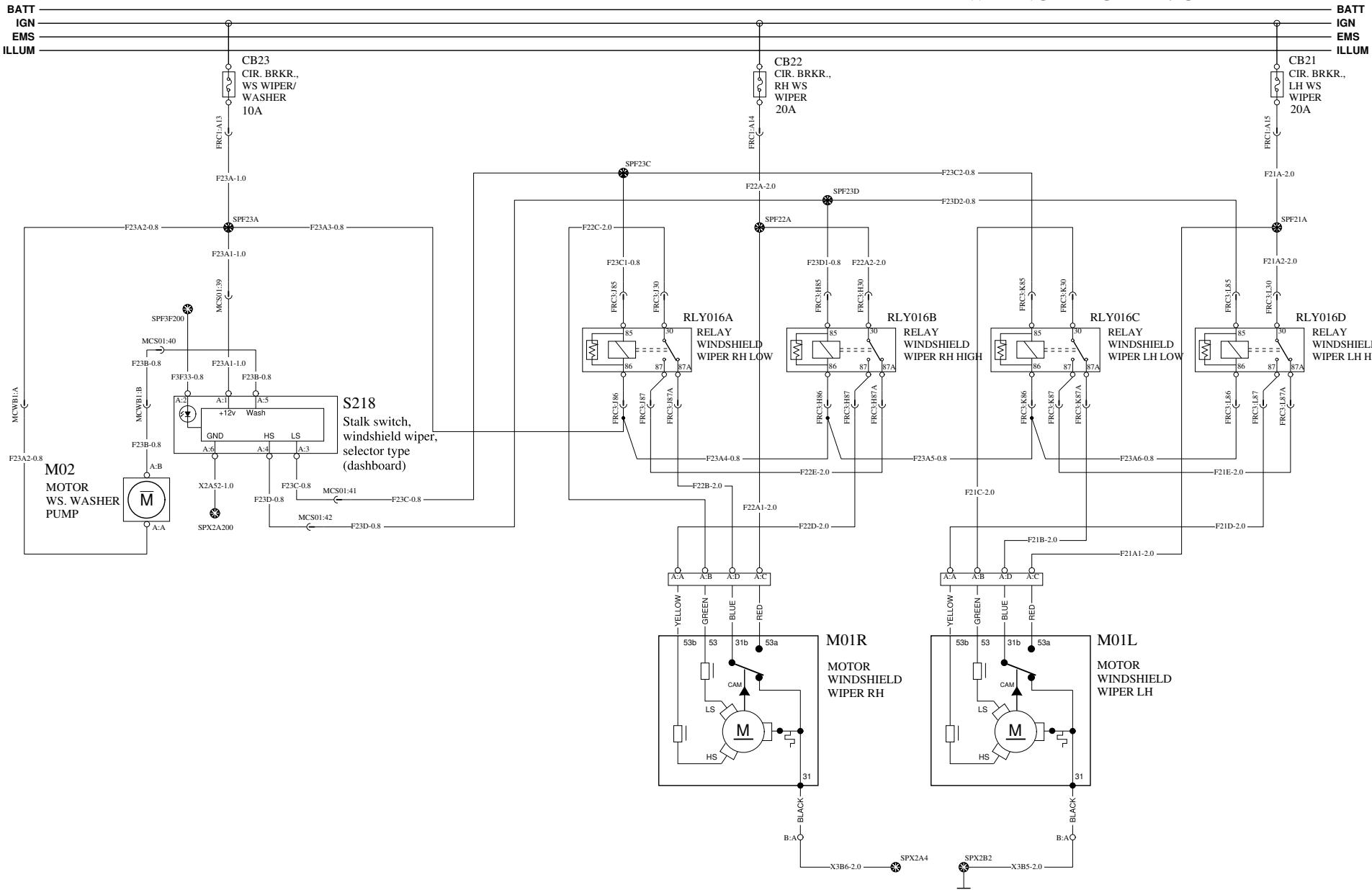

HORN WIRING

WIRING DIAGRAM: GQ

BATT  
IGN  
EMS  
ILLUM

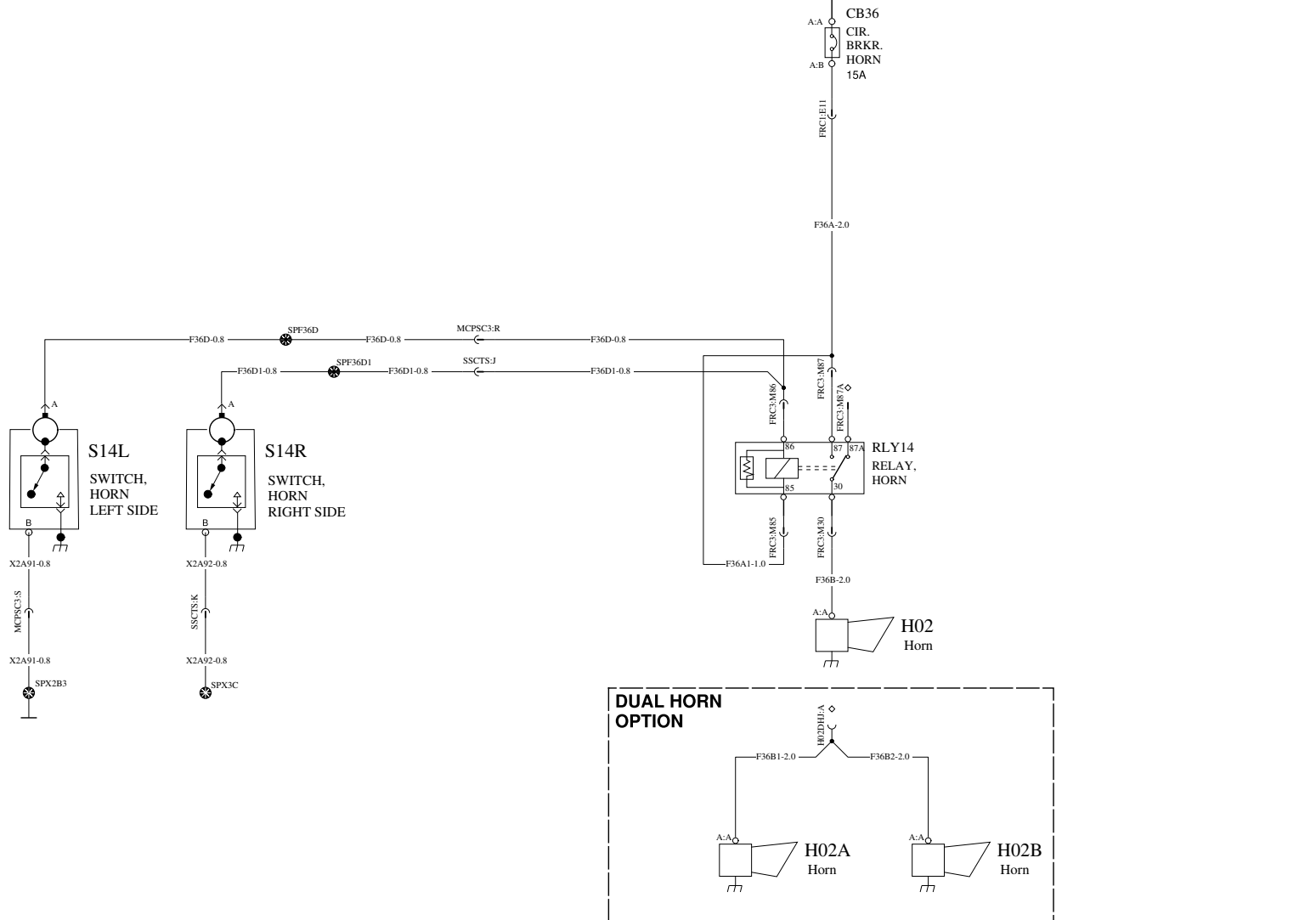

Volvo Truck Corporation

Document title  
WIRING DIAGRAM TYPE OL  
Document type  
PRODUCT SCHEMATIC

Document No	Issue	Volume	Page
24403869	01	1 (2)	42 (57)

# CLIMATE CONTROL

# WIRING DIAGRAM: HA

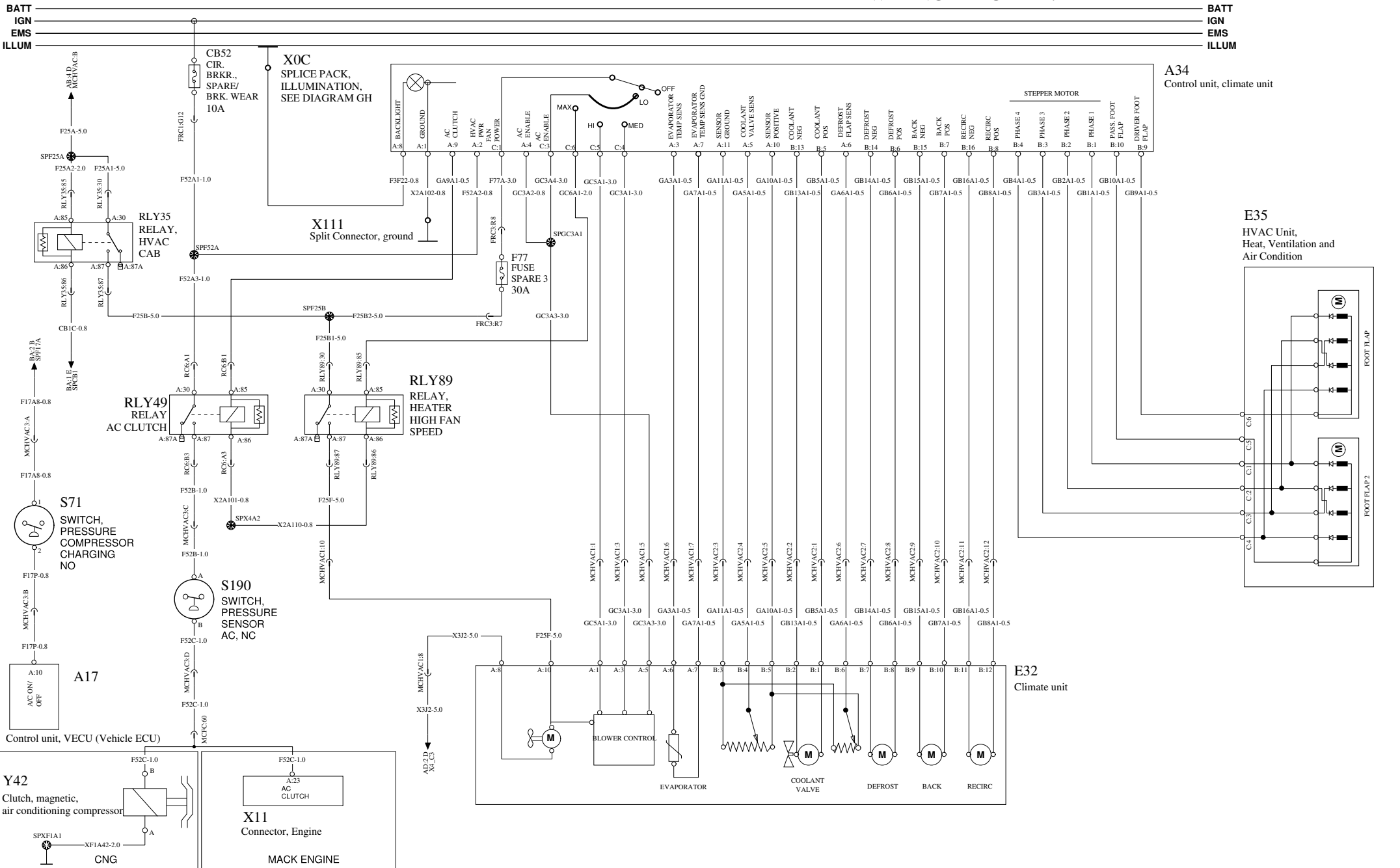

# MIRRORS DUAL REMOTE

# WIRING DIAGRAM: IC

BATT  
IGN  
EMS  
ILLUM

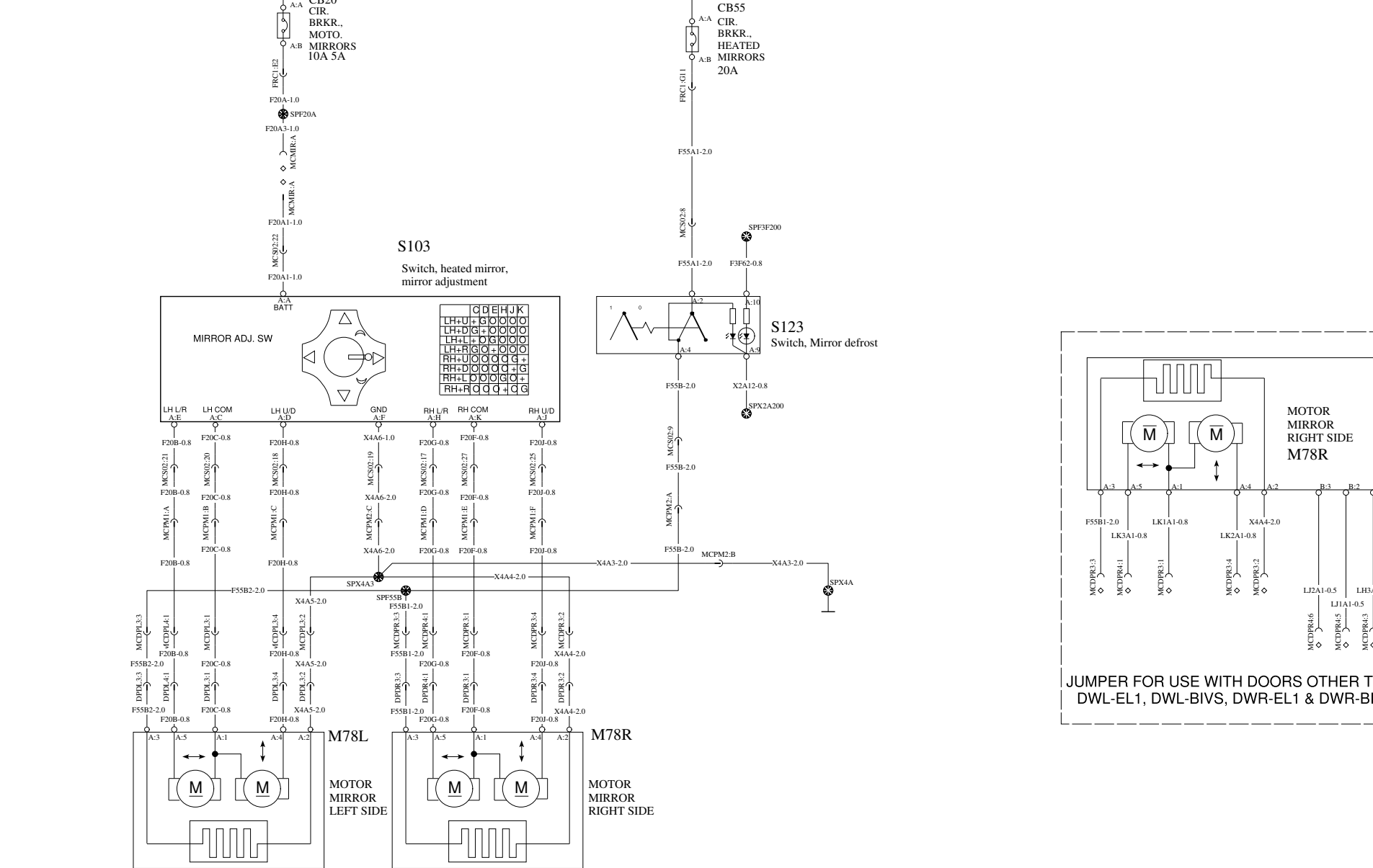



POWER WINDOWS

WIRING DIAGRAM: IE

BATT  
IGN  
EMS  
ILLUM

BATT  
IGN  
EMS  
ILLUM

CB56  
POWER WINDOW DRIVERS SIDE 20A

CB57  
POWER WINDOW PASSENGER SIDE 20A

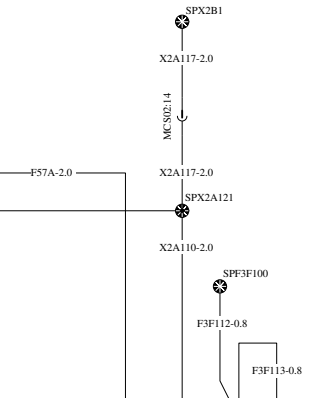
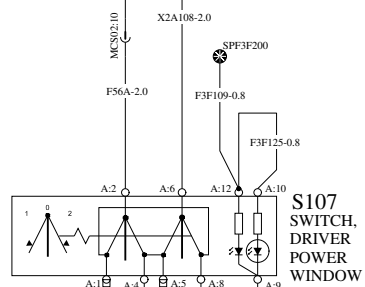

DRIVER driver MOTOR, Motor, P.WINDOW side winder window

MOTOR, Motor, P.WINDOW PASSENGER passenger side winder window

POWER DOOR LOCKS

WIRING DIAGRAM: IF

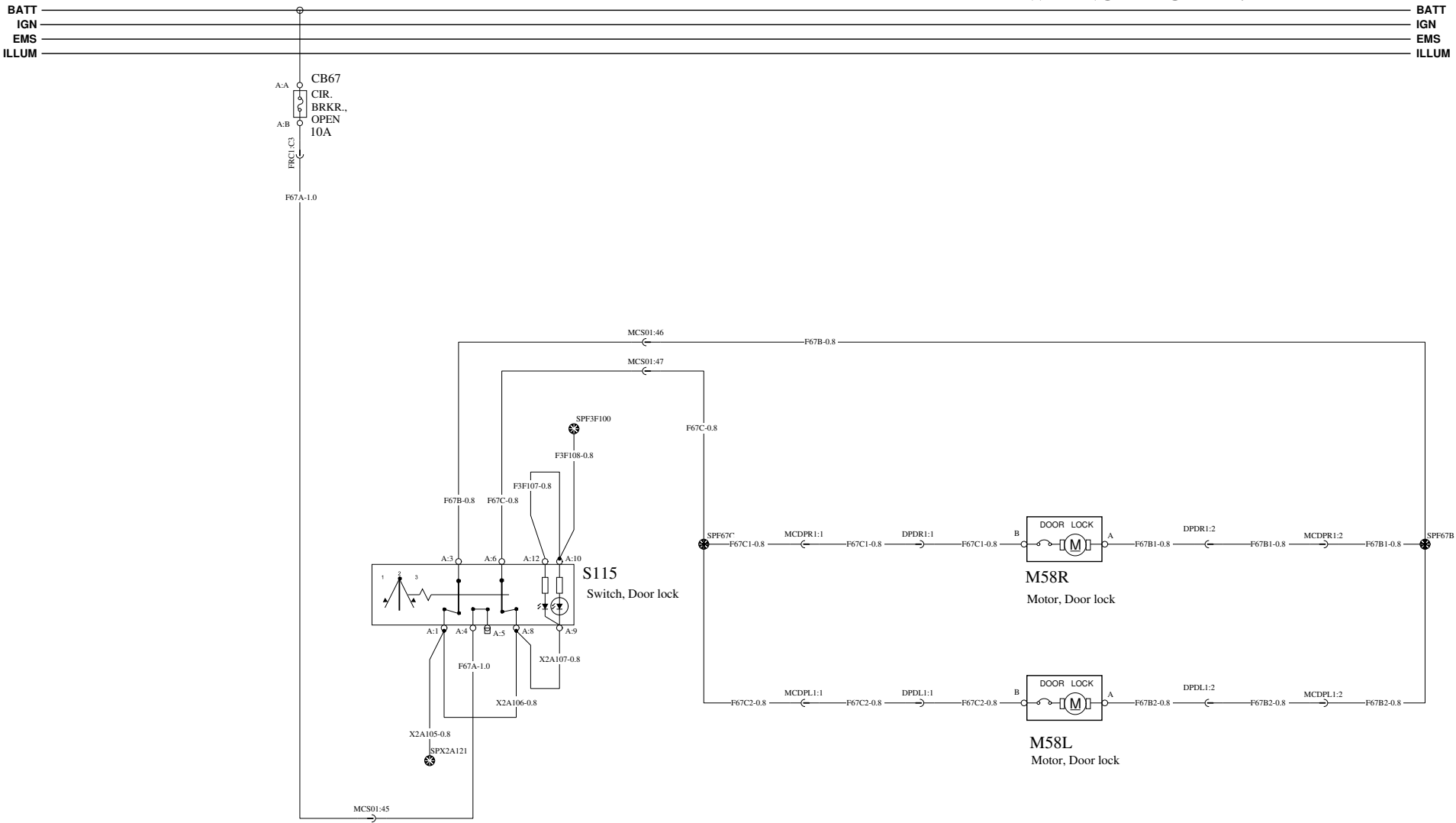



LANE DEPARTURE

WIRING DIAGRAM: JG

BATT  
EMS

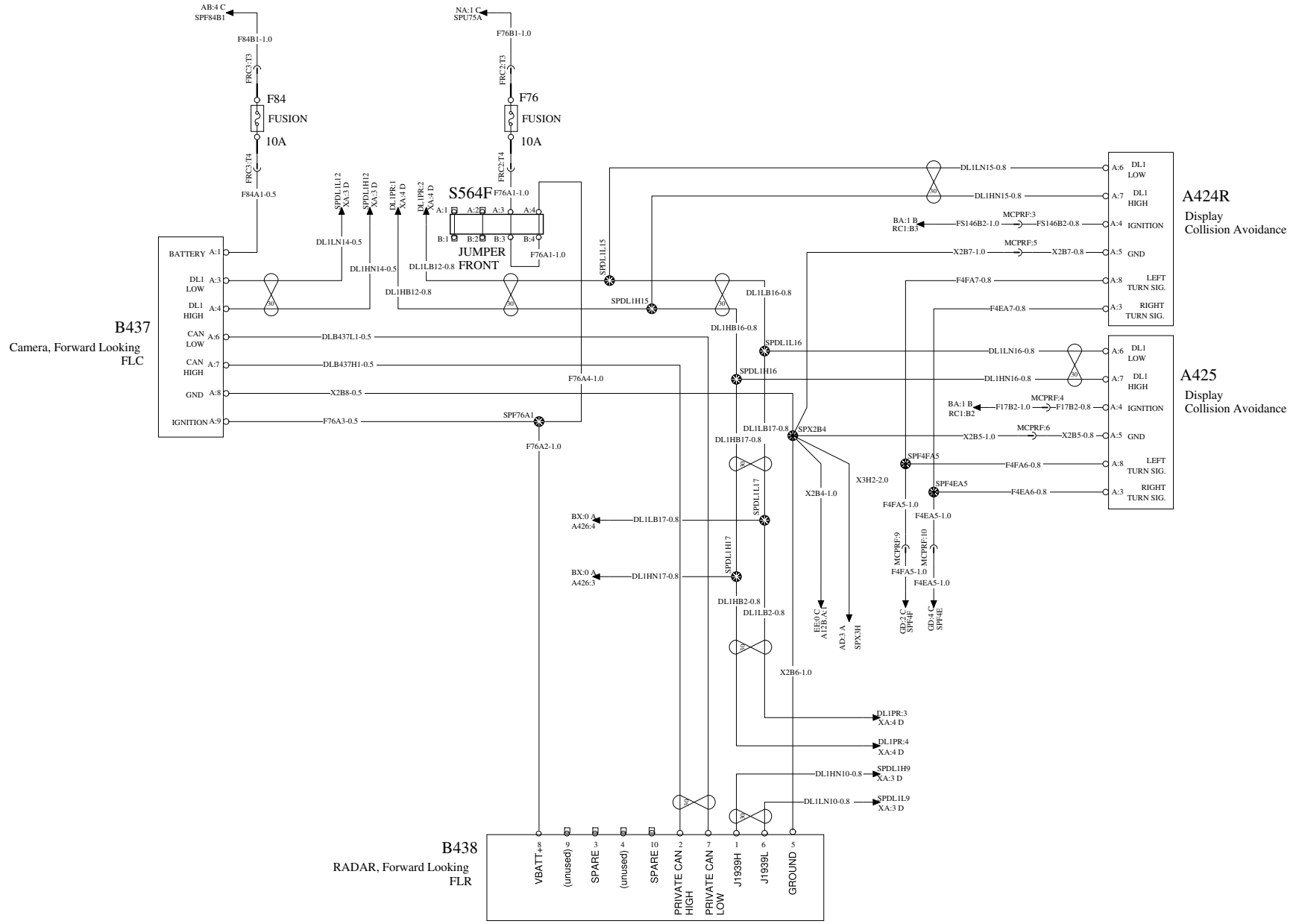

# AUDIO & VISUAL SYSTEMS

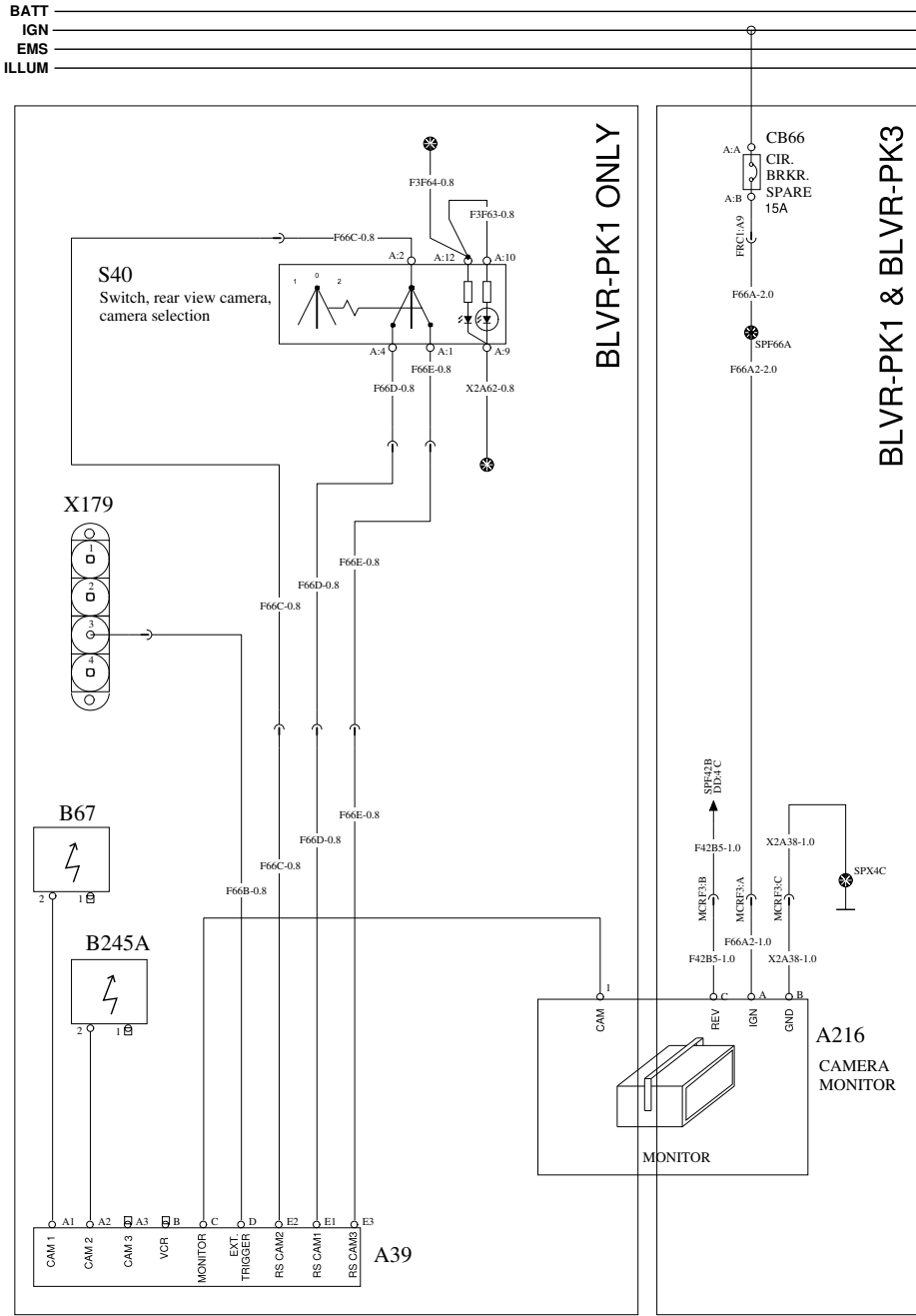

# WIRING DIAGRAM: KA

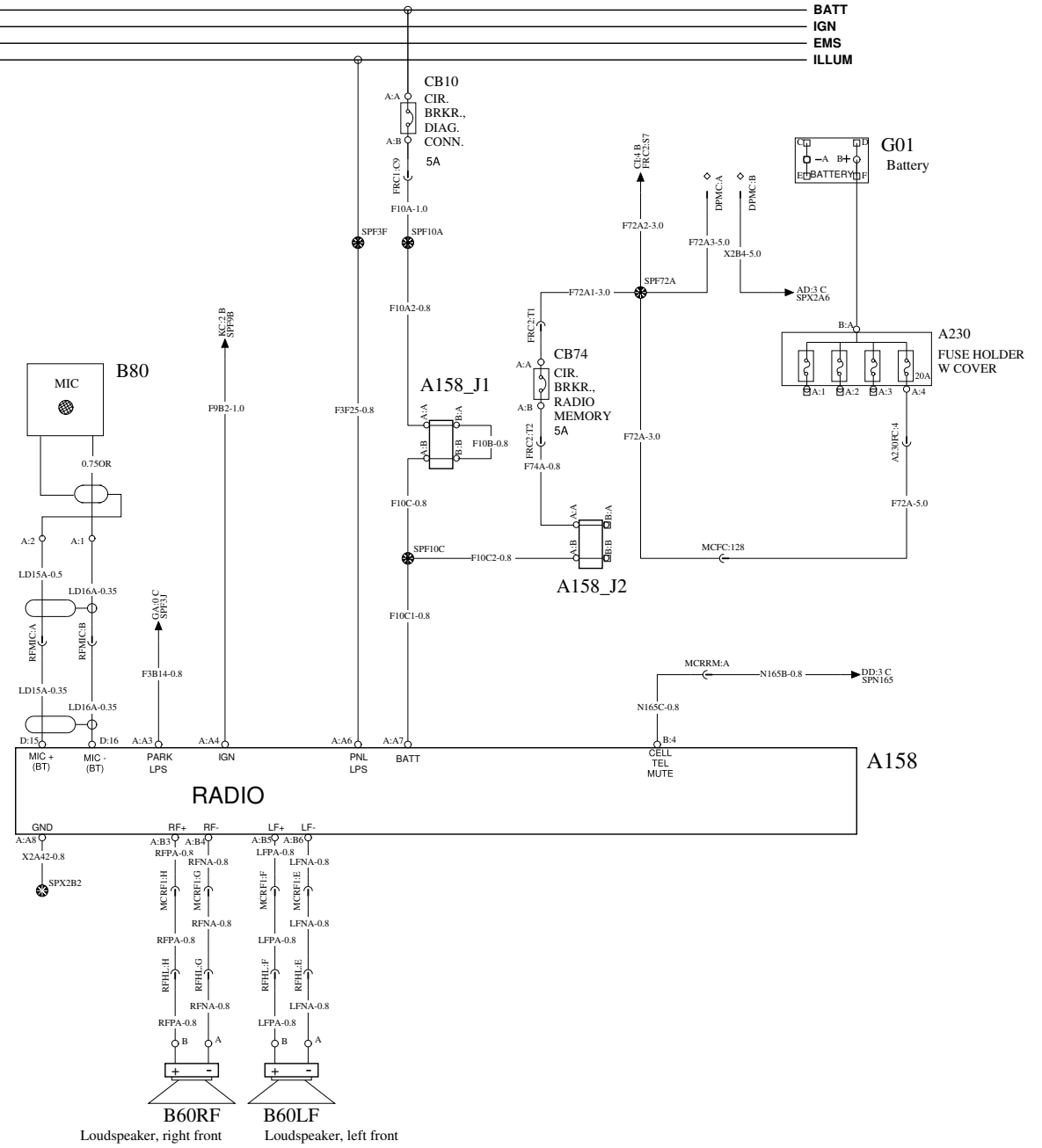

POWER OUTLET CONNECTIONS

WIRING DIAGRAM: KC

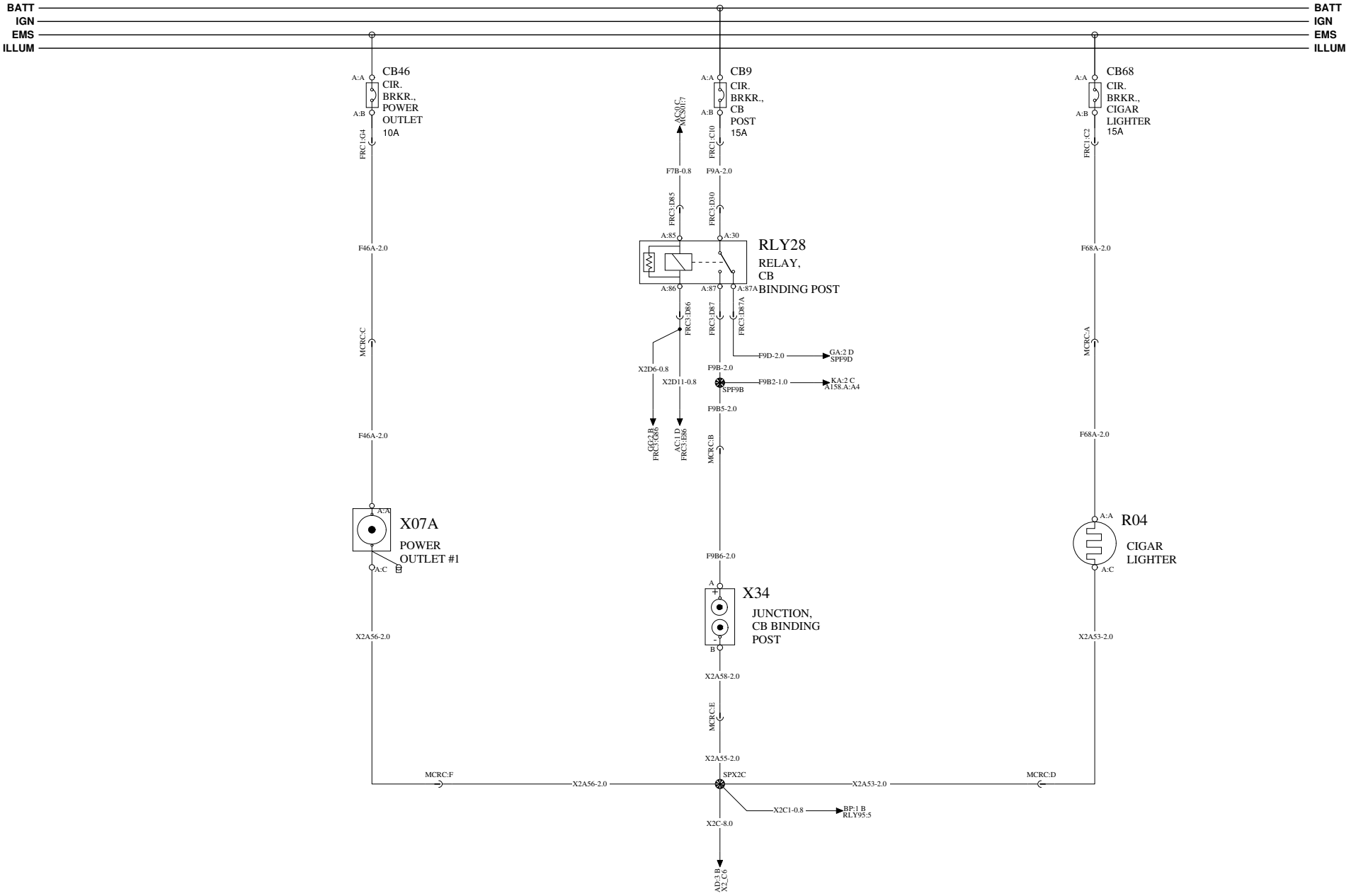

SPARE CONNECTIONS AND FEEDS

WIRING DIAGRAM: NA

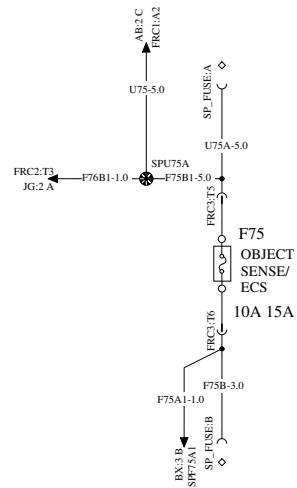
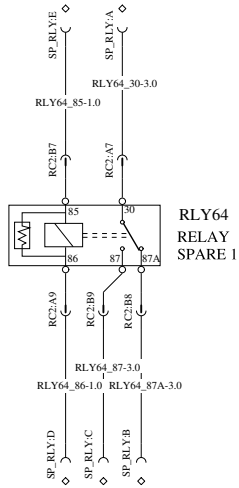
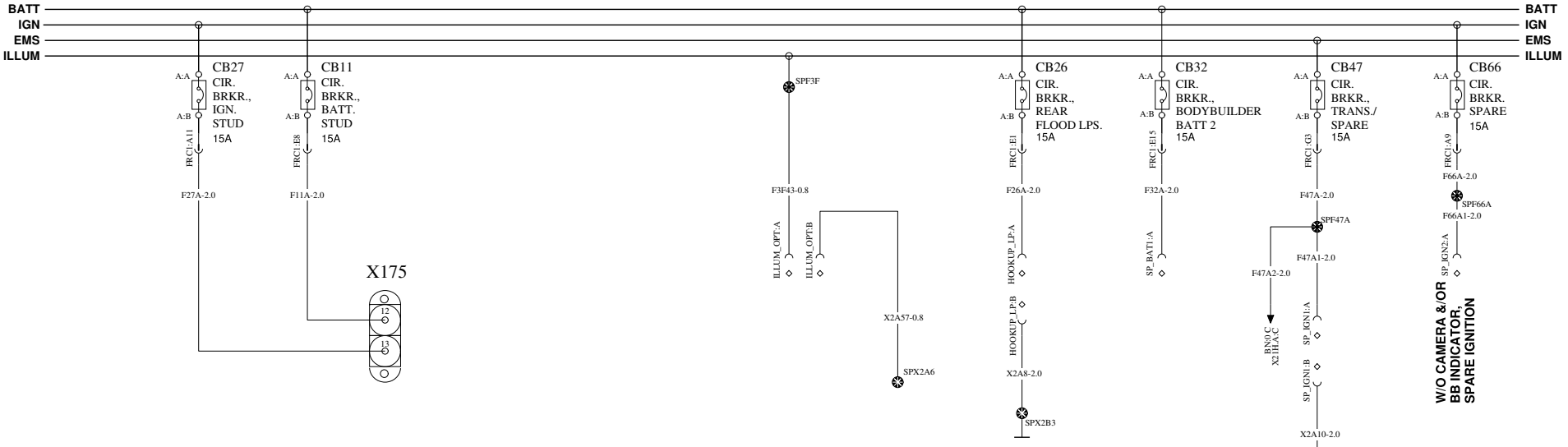

JUNCTION POSTS

WIRING DIAGRAM: NB

BATT  
IGN  
EMS  
ILLUM

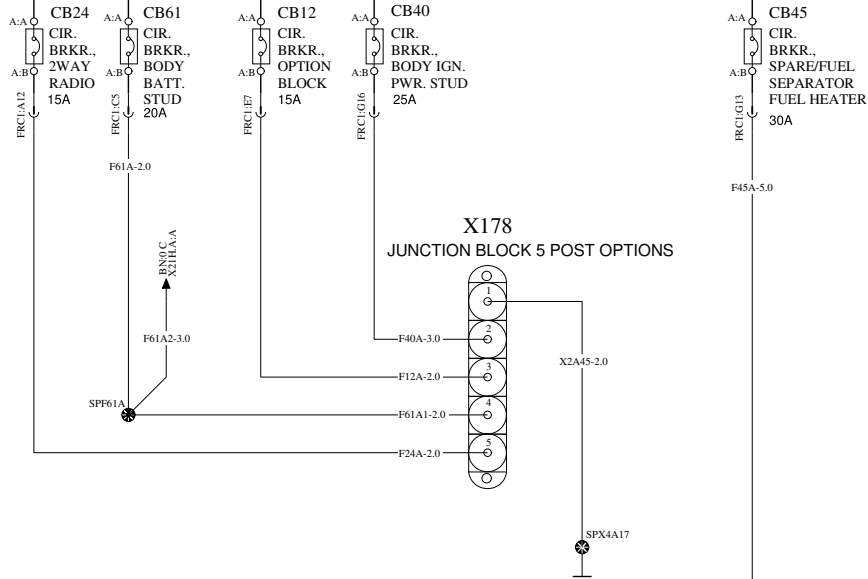

X178  
JUNCTION BLOCK 5 POST OPTIONS

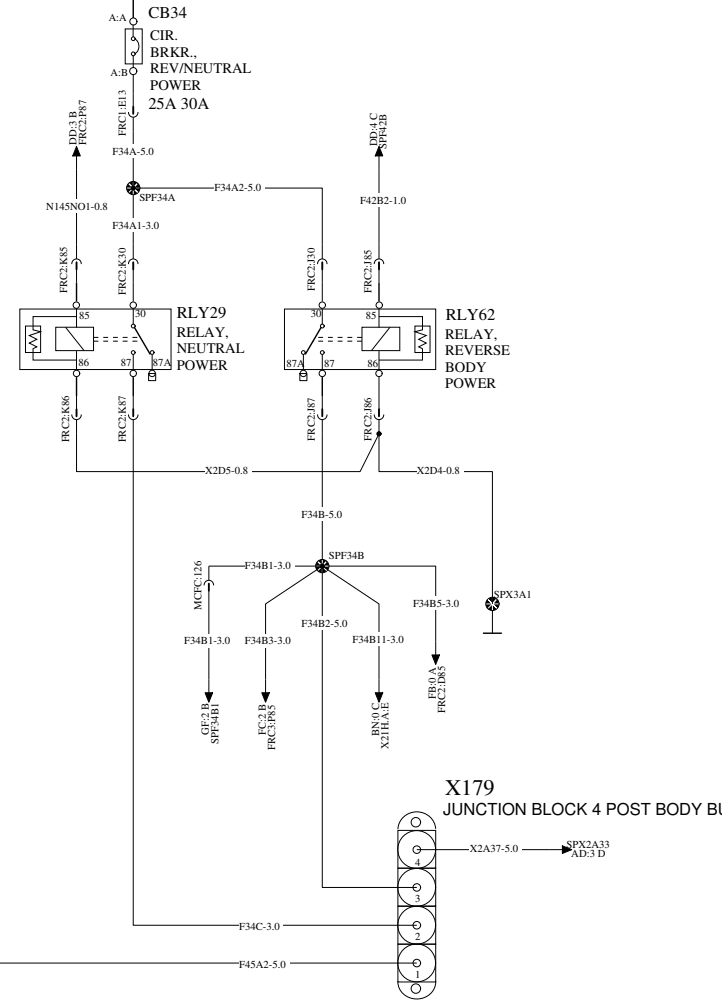

X179  
JUNCTION BLOCK 4 POST BODY BUILDER

OBD - DATA LINK 1 & DIAGNOSTICS - MACK ENGINE

WIRING DIAGRAM: XA

BATT  
IGN  
EMS  
ILLUM

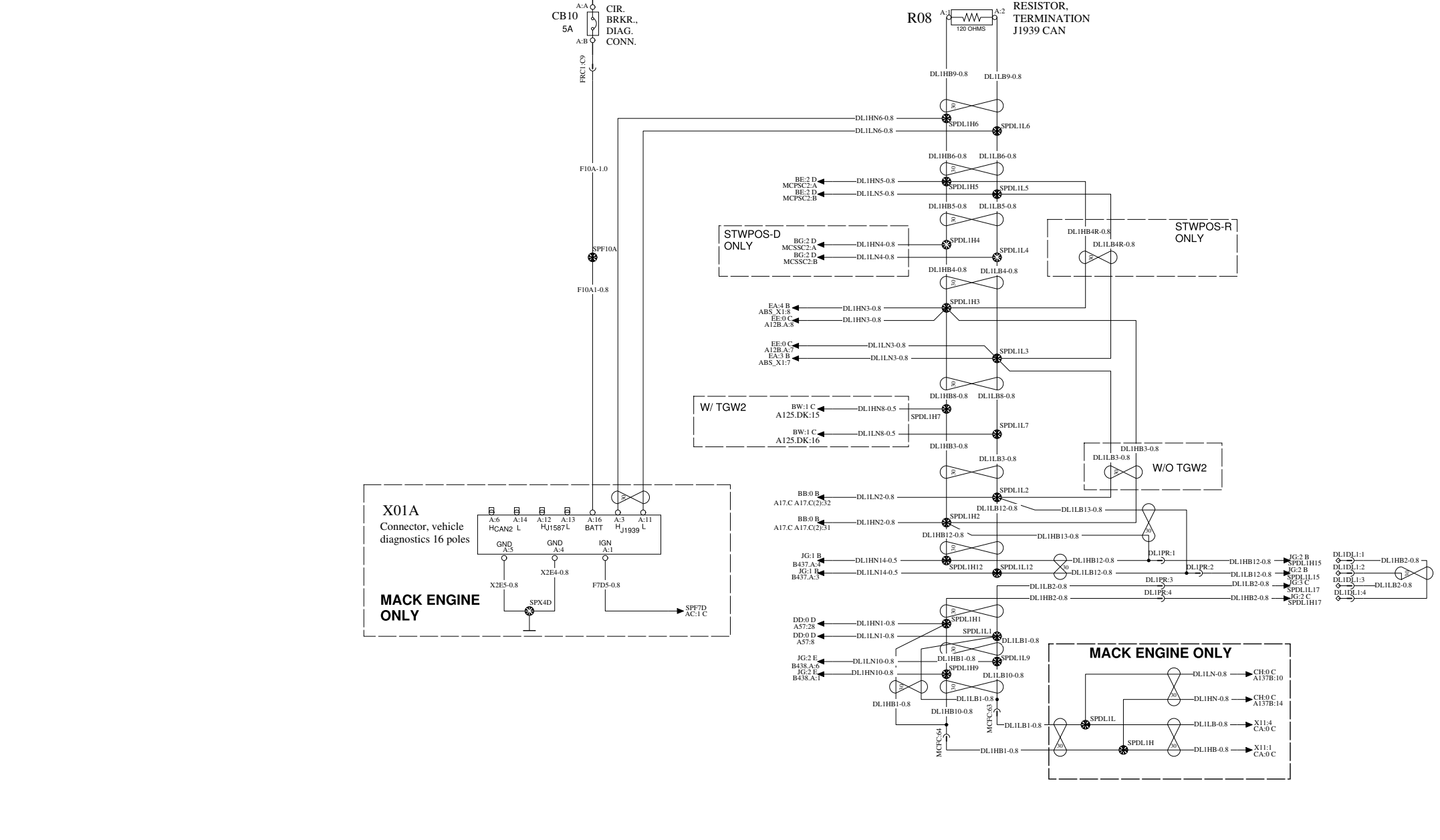

# OBD - DATA LINK 1 & DIAGNOSTICS - 2018 CNG

# WIRING DIAGRAM: XB

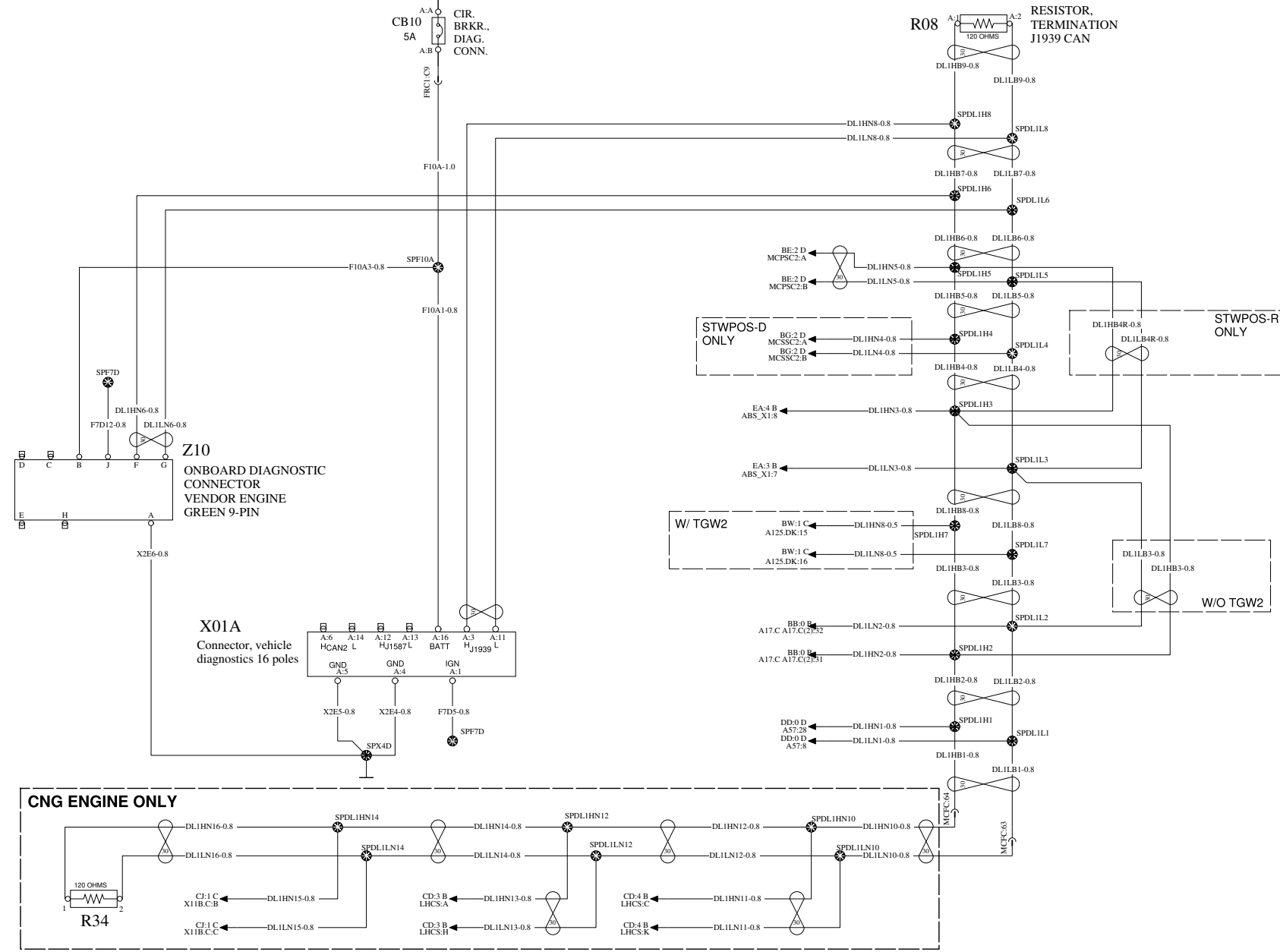
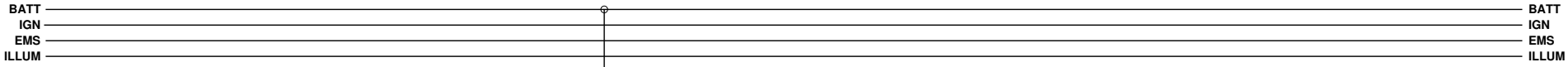

Volvo Truck Corporation		Document title	Document No	Issue	Volume	Page
		WIRING DIAGRAM TYPE OL	24403869	01	1 (2)	54 (57)
		Document type				
		PRODUCT SCHEMATIC				

OBD - DATA LINK 2

WIRING DIAGRAM: XC

BATT  
IGN  
EMS  
ILLUM

BATT  
IGN  
EMS  
ILLUM

W/O TGW2

W/ TGW2

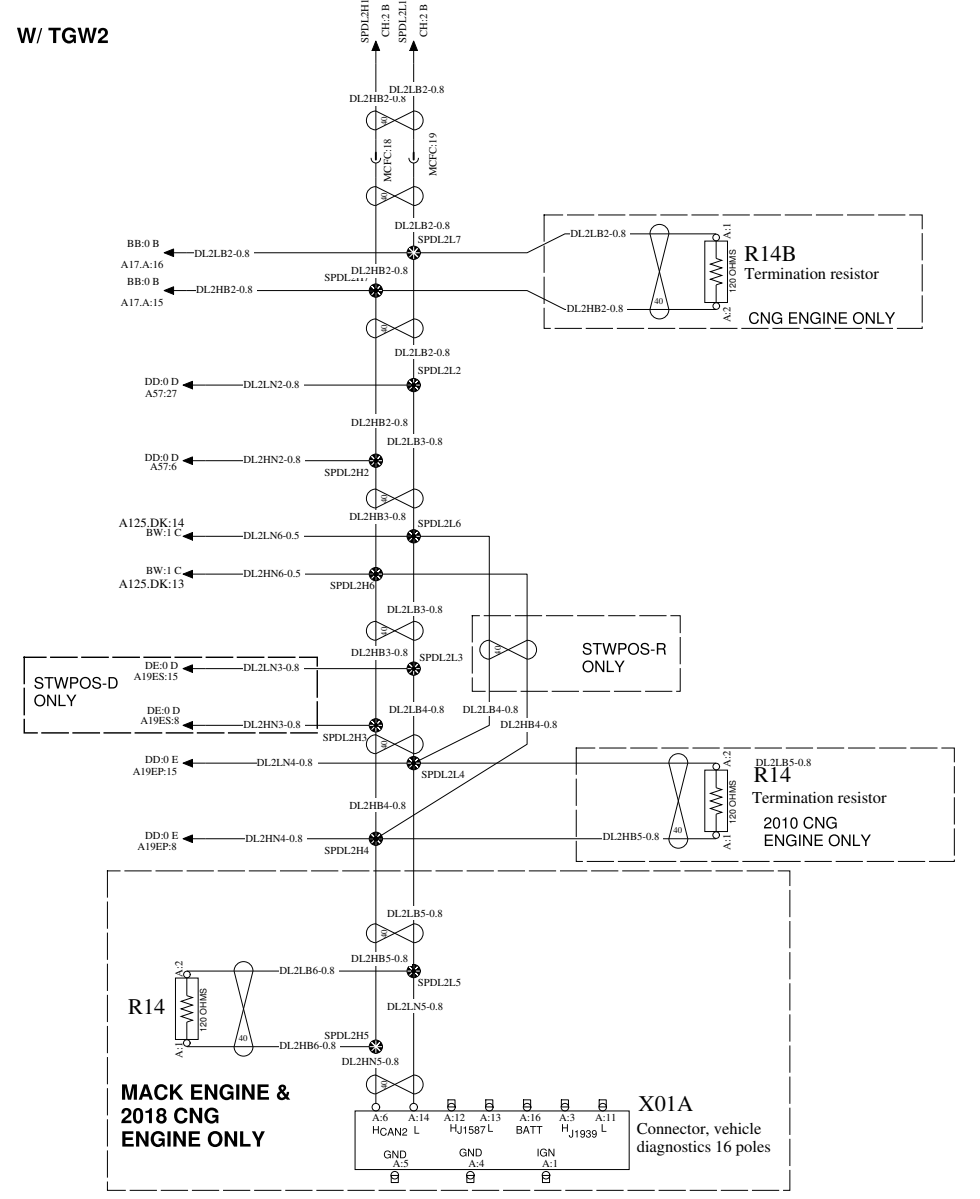
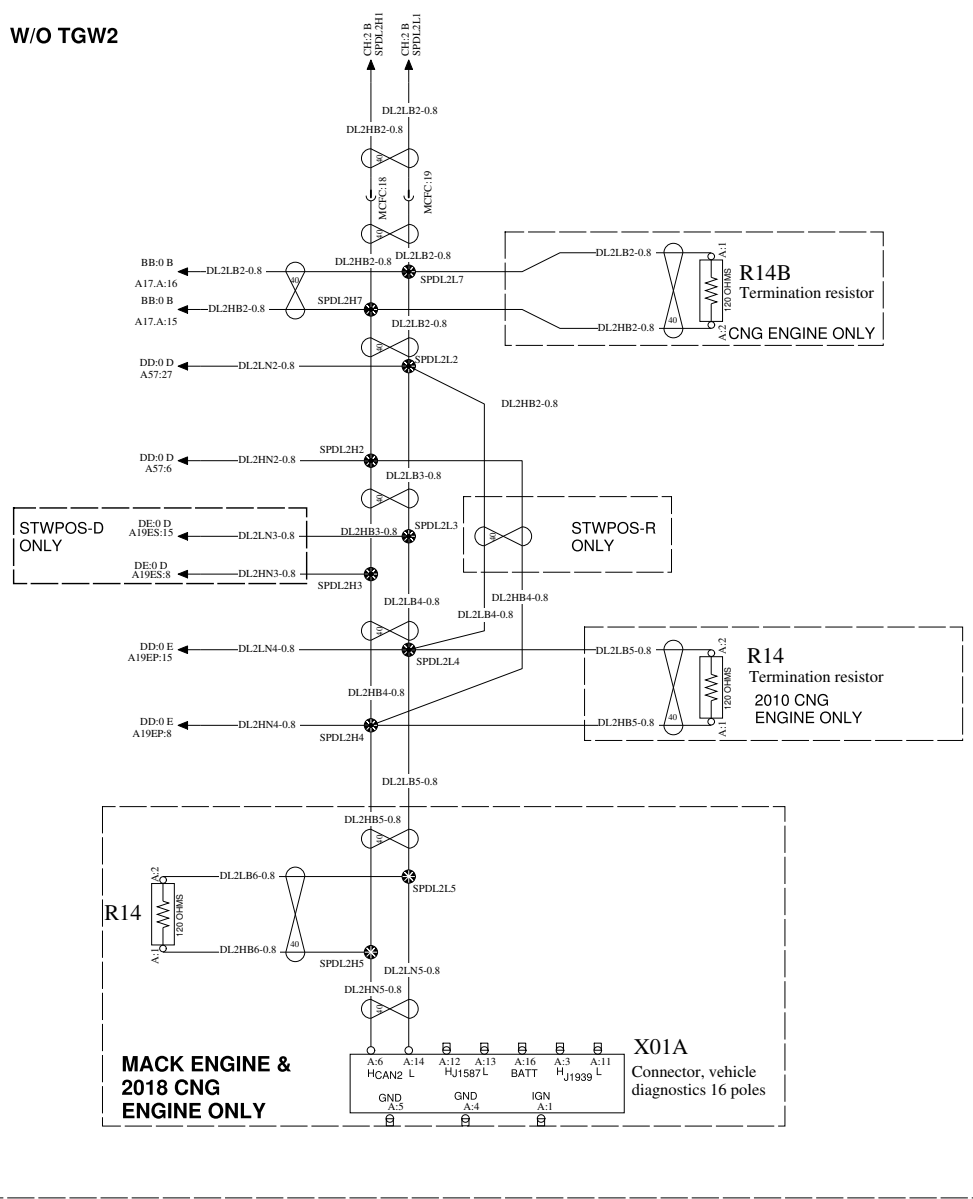



OBD - DATA LINK 4

WIRING DIAGRAM: XD

BATT  
IGN  
EMS  
ILLUM

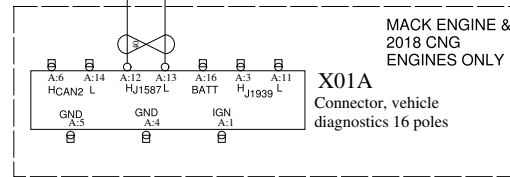
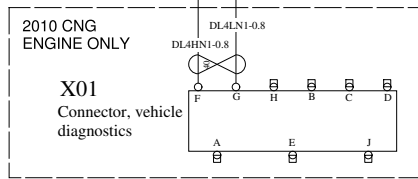
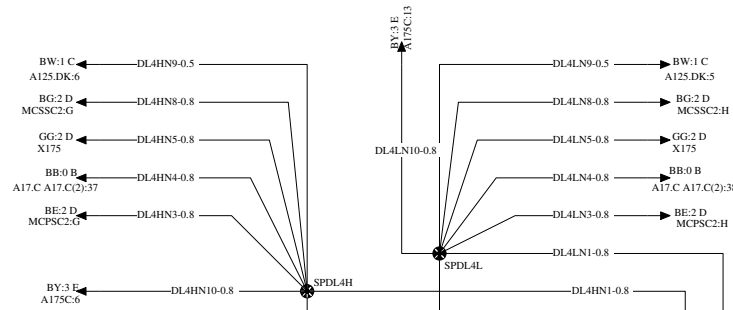

OBD - DATALINK 10

WIRING DIAGRAM: XE

BATT	BATT
IGN	IGN
EMS	EMS
ILLUM	ILLUM

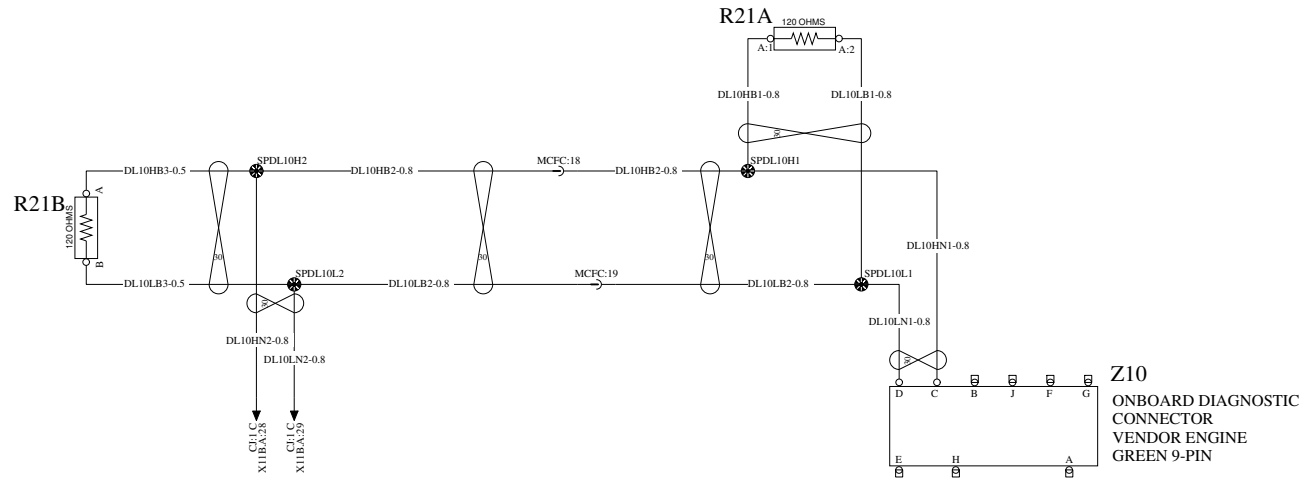

Volvo Truck Corporation

Document title  
WIRING DIAGRAM TYPE OL

Document type  
PRODUCT SCHEMATIC

Document No

24403869

Issue

01

Volume

1 (2)

Page

57 (57)

0

1

2

3

4

## CABLES

HARNESS	PARTNO	PAGE
FRONT_CHASSIS	GXL_21726662	CA 3 B
FRONT_CHASSIS	GXL_21726662	CA 3 E
ROOF	MKFK_0.35_981996	KA 2 C
STEERING_COLUMN	30T_TXL_Y-GN_0.8	BG 2 C
STANTION_HARNESS	GXL_21726662	CD 4 B
FRONT_CHASSIS	RADXL_21726662	XE 2 C
DRIVECAM_OL	30T_TXL_2-W/OR_1.0	BY 2 B
MAIN_CAB	30T_TXL_Y-GN_0.8	BB 1 D
MAIN_CAB	30T_TXL_Y-GN_0.8	BB 1 C
MAIN_CAB	30T_GXL_2_Y/GN_0.8	XB 4 D
MAIN_CAB	30T_GXL_2_Y/GN_0.8	EE 3 C
MAIN_CAB	30T_GXL_2_Y/GN_0.8	XA 3 D
MAIN_CAB	30T_GXL_2_Y/GN_0.8	XA 3 D
MAIN_CAB	30T_TXL_Y-GN_0.8	BB 1 C
PRECO_ROOF	30T_GXL_2_Y/GN_0.8	JG 3 C
STANTION_HARNESS	GXL_21726662	CD 3 B
MAIN_CAB	40T_TXL_2-W/OR_0.5	BW 1 C
FRONT_CHASSIS	RADXL_21726662	XB 3 E
MAIN_CAB	30T_GXL_2_Y/GN_0.8	XA 3 A
MAIN_CAB	30T_GXL_2_Y/GN_0.8	XA 3 D
UREA_TANK_EXTENSION	GXL_21726662	CA 3 D
MAIN_CAB	30T_TXL_Y-GN_0.8	BB 0 C
MAIN_CAB	30T_TXL_2_Y_GN_0.5	JG 1 B
MAIN_CAB	30T_GXL_2_Y/GN_0.8	BE 2 C
MAIN_CAB	30T_GXL_2_Y/GN_0.8	XE 2 D
MAIN_CAB	30T_GXL_2_Y/GN_0.8	XB 2 D
PRECO_ROOF	30T_GXL_2-W/OR_0.8	BX 1 C
PRECO_ROOF	30T_GXL_2_Y/GN_0.8	JG 2 B
MAIN_CAB	30T_GXL_2_Y/GN_0.8	XA 3 D
FRONT_CHASSIS	GXL_21726662	CH 1 B
MAIN_CAB	30T_GXL_2-W/OR_0.8	BX 1 D
MAIN_CAB	30T_GXL_2_Y/GN_0.8	XA 3 B
MAIN_CAB	30T_GXL_2_Y/GN_0.8	XE 2 B
ROOF	30T_TXL_2-W/OR_0.8	BY 2 D
FRONT_CHASSIS	GXL_21726662	XA 4 D
MAIN_CAB	30T_GXL_2_Y/GN_0.8	XB 4 B
PRECO_ROOF	30T_GXL_2_Y/GN_0.8	BX 0 B
PRECO_ROOF	30T_GXL_2_Y/GN_0.8	JG 2 C
MAIN_CAB	30T_GXL_2_Y/GN_0.8	XA 3 D
PRECO_ROOF	30T_GXL_2_Y/GN_0.8	JG 3 B
PRECO_ROOF	30T_GXL_2-W/OR_0.8	BX 1 B
MAIN_CAB	30T_GXL_2_Y/GN_0.8	XA 3 D
MAIN_CAB	30T_GXL_2_Y/GN_0.8	XE 3 C
ROOF	30T_TXL_2-W/OR_0.8	BY 2 C
FRONT_CHASSIS	RADXL_21726662	XB 2 E
MAIN_CAB	30T_GXL_2-W/OR_0.8	BX 1 C
PRECO_ROOF	30T_GXL_2-W/OR_0.8	JG 2 D
MAIN_CAB	30T_TXL_2_Y_GN_0.5	BW 2 C
ROOF	30T_TXL_2-W/OR_0.8	BY 2 C
FRONT_CHASSIS	RADXL_21726662	XB 1 E

HARNESS	PARTNO	PAGE
MAIN_CAB	30T_GXL_2_Y/GN_0.8	XA 3 C
FRONT_CHASSIS	RADXL_21726662	XE 1 C
DRIVECAM_OL	30T_TXL_2-W/OR_0.8	BY 2 B
MAIN_CAB	30T_GXL_2_Y/GN_0.8	XB 4 D
PRECO_ROOF	30T_GXL_2-W/OR_0.8	BX 0 C
MAIN_CAB	30T_GXL_2_Y/GN_0.8	XA 3 B
FRONT_CHASSIS	RADXL_22566647	XE 1 C
DRIVECAM_OL	30T_TXL_2-W/OR_0.8	BY 2 B
FRONT_CHASSIS	RADXL_21726662	XB 3 E
MAIN_CAB	30T_GXL_2_Y/GN_0.8	XA 3 B
DRIVECAM_OL	30T_TXL_2-W/OR_0.8	BY 2 B
FRONT_CHASSIS	RADXL_21726662	XB 4 E
MAIN_CAB	30T_GXL_2_Y/GN_0.8	XA 3 D
MAIN_CAB	30T_GXL_2_Y/GN_0.8	BG 2 D
MAIN_CAB	30T_GXL_2_Y/GN_0.8	XB 1 C
MAIN_CAB	30T_GXL_2_Y/GN_0.8	XA 4 D
FRONT_CHASSIS	GXL_21726662	XA 3 E
MAIN_CAB	30T_GXL_2_Y/GN_0.8	XA 3 B
MAIN_CAB	30T_GXL_2_Y/GN_0.8	XB 4 C
MAIN_CAB	30T_GXL_2_Y/GN_0.8	JG 2 D
MAIN_CAB	30T_GXL_2_Y/GN_0.8	XA 2 C
MAIN_CAB	30T_GXL_2_Y/GN_0.8	XB 4 B
PRECO_ROOF	30T_GXL_2_Y/GN_0.8	JG 2 D
MAIN_CAB	30T_GXL_2_Y/GN_0.8	XB 4 D
PRECO_ROOF	30T_GXL_2_Y/GN_0.8	JG 2 B
FRONT_CHASSIS	GXL_21726662	XA 4 E
MAIN_CAB	30T_GXL_2-W/OR_0.8	BX 1 C
FRONT_CHASSIS	RADXL_21726662	XB 3 E
MAIN_CAB	30T_GXL_2_Y/GN_0.8	XB 4 D
MAIN_CAB	30T_GXL_2_Y/GN_0.8	XB 4 B
MAIN_CAB	30T_GXL_2_Y/GN_0.8	XB 4 A
UREA_TANK	GXL_21726662	CA 3 C
FRONT_CHASSIS	RADXL_21726662	CJ 1 C
UREA_TANK	GXL_21726662	CA 3 C
MAIN_CAB	30T_GXL_2_Y/GN_0.8	XB 4 C
UREA_TANK	GXL_21726662	CA 3 D
MAIN_CAB	30T_GXL_2_Y/GN_0.8	XB 4 B
MAIN_CAB	30T_GXL_2_Y/GN_0.8	XA 3 C
MAIN_CAB	30T_GXL_2_Y/GN_0.8	DD 4 E
UREA_TANK_EXTENSION	GXL_21726662	CA 3 C
MAIN_CAB	30T_GXL_2_Y/GN_0.8	DD 4 D
MAIN_CAB	30T_GXL_2_Y/GN_0.8	XA 3 C
MAIN_CAB	30T_TXL_2_Y_GN_0.5	BW 2 B
MAIN_CAB	30T_GXL_2_Y/GN_0.8	XB 3 B
MAIN_CAB	30T_GXL_2_Y/GN_0.8	BG 2 D
MAIN_CAB	30T_GXL_2_Y/GN_0.8	EA 3 B
MAIN_CAB	30T_GXL_2_Y/GN_0.8	EA 3 B
ABS_JUMPER	30T_GXL_2_Y/GN_0.8	EA 3 C
MAIN_CAB	30T_TXL_Y-GN_0.8	BB 1 C
FRONT_CHASSIS	40T_TXL_2-W/OR_0.8	DC 0 B

Volvo Truck Corporation

Document title  
WIRING DIAGRAM TYPE OL

Document type  
PRODUCT SCHEMATIC

Document No

24403869

Issue

01

Volume

2 (2)

Page

6 (63)

0

1

2

3

4

## CABLES

HARNESS	PARTNO	PAGE
STEERING_COLUMN	40T_TXL_2-W/OR_0.8	BE 2 D
MAIN_CAB	40T_TXL_2-W/OR_0.5	BW 1 C
FRONT_CHASSIS	40T_TXL_2-W/OR_0.8	CH 2 C
FRONT_CHASSIS	40T_GXL_2-W/OR_0.8	EA 2 D
FRONT_CHASSIS	40T_GXL_2-W/OR_0.8	EE 1 D
STEERING_COLUMN	W_W_40t_m_TXL	EF 1 D
MAIN_CAB	40T_TXL_2-W/OR_0.8	DC 0 B
FRONT_CHASSIS	40T_TXL_2-W/OR_0.8	DC 0 B
STEERING_COLUMN	40T_TXL_2-W/OR_0.8	BG 2 C
MAIN_CAB	40T_TXL_2-W/OR_0.8	XC 4 C
MAIN_CAB	40T_TXL_2-W/OR_0.5	BY 2 D
FRONT_CHASSIS	40T_TXL_2-W/OR_0.8	CA 0 D
MAIN_CAB	40T_TXL_2-W/OR_0.8	EA 2 D
MAIN_CAB	40T_GXL_4_W/OR_1.0	EF 1 B
MAIN_CAB	40T_TXL_2-W/OR_0.8	DC 0 B
FRONT_CHASSIS	40T_TXL_2-W/OR_0.8	DC 0 B
MAIN_CAB	40T_TXL_2-W/OR_0.8	XC 1 B
MAIN_CAB	40T_TXL_2-W/OR_0.8	BG 2 D
MAIN_CAB	40T_TXL_2-W/OR_0.8	XC 4 D
DRIVECAM_OL	40T_TXL_2-W/OR_0.8	BY 2 D
FRONT_CHASSIS	40T_TXL_2-W/OR_0.8	CH 3 C
ABS_JUMPER	40T_TXL_2-W/OR_0.8	EA 2 C
MAIN_CAB	40T_GXL_4_W/OR_1.0	EF 1 D
MAIN_CAB	40T_TXL_2-W/OR_0.8	DC 0 B
MAIN_CAB	40T_TXL_2-W/OR_0.8	XC 1 B
MAIN_CAB	40T_TXL_2-W/OR_0.8	BE 2 D
MAIN_CAB	40T_TXL_2-W/OR_0.8	XC 4 C
MAIN_CAB	40T_TXL_2-W/OR_0.8	BY 2 D
REAR_CHASSIS_EXTENSION	40T_GXL_2-W/OR_0.8	EA 2 D
FRONT_CHASSIS	40T_GXL_4_W/OR_1.0	EF 2 D
MAIN_CAB	40T_TXL_2-W/OR_0.8	BB 1 D
MAIN_CAB	40T_TXL_2-W/OR_0.8	XC 4 C
REAR_CHASSIS_EXTENSION	40T_GXL_2-W/OR_0.8	EA 2 D
MAIN_CAB	40T_GXL_4_W/OR_1.0	EF 1 C
REAR_CHASSIS_EXTENSION	40T_GXL_2-W/OR_0.8	EA 0 D
MAIN_CAB	40T_TXL_2-W/OR_0.8	XC 4 B
FRONT_CHASSIS	40T_GXL_2-W/OR_0.8	EA 2 D
FRONT_CHASSIS	40T_GXL_2-W/OR_0.8	EE 2 D
REAR_CHASSIS_EXTENSION	40T_GXL_2-W/OR_0.8	EA 1 D
MAIN_CAB	40T_TXL_2-W/OR_0.8	DE 1 D
AUTOTRANS_TRANS	40T_TXL_2-W/OR_0.8	DC 0 D
MAIN_CAB	40T_TXL_2-W/OR_0.8	XC 3 D
ABS_JUMPER	40T_TXL_2-W/OR_0.8	EA 2 C
FRONT_CHASSIS	40T_GXL_2-W/OR_0.8	EE 2 B
MAIN_CAB	40T_TXL_2-W/OR_0.8	ED 2 D
AUTOTRANS_TRANS	40T_TXL_2-W/OR_0.8	DC 0 D

HARNESS	PARTNO	PAGE
MAIN_CAB	40T_TXL_2-W/OR_0.8	EA 2 D
FRONT_CHASSIS	40T_GXL_2-W/OR_0.8	EE 1 B
AUTOTRANS_TRANS	40T_TXL_2-W/OR_0.8	DC 0 D
MAIN_CAB	40T_TXL_2-W/OR_0.8	XC 4 B
FRONT_CHASSIS	40T_GXL_2-W/OR_0.8	EE 0 B
MAIN_CAB	40T_TXL_2-W/OR_0.8	DD 4 D
AUTOTRANS_TRANS	40T_TXL_2-W/OR_0.8	DC 0 D
MAIN_CAB	40T_TXL_2-W/OR_0.8	EE 0 C
MAIN_CAB	40T_TXL_2-W/OR_0.8	XC 4 E
MAIN_CAB	40T_TXL_2-W/OR_0.8	EE 1 C
MAIN_CAB	40T_TXL_2-W/OR_0.8	DD 2 D
MAIN_CAB	40T_TXL_2-W/OR_0.8	EE 2 C
MAIN_CAB	40T_TXL_2-W/OR_0.8	GG 1 C
MAIN_CAB	40T_TXL_2-W/OR_0.8	XC 4 C
MAIN_CAB	40T_TXL_2-W/OR_0.8	EE 1 D
MAIN_CAB	40T_TXL_2-W/OR_0.8	DE 2 D
MAIN_CAB	40T_TXL_2-W/OR_0.8	EE 2 D
MAIN_CAB	40T_TXL_2-W/OR_0.8	DD 3 E
REAR_CHASSIS_EXTENSION	40T_GXL_W/OR_1.0	EE 0 B
MAIN_CAB	40T_TXL_2-W/OR_0.8	XC 1 D
REAR_CHASSIS_EXTENSION	40T_GXL_W/OR_1.0	EE 1 D
MAIN_CAB	40T_TXL_2-W/OR_0.8	XD 2 C
REAR_CHASSIS_EXTENSION	40T_GXL_W/OR_1.0	EE 2 D
MAIN_CAB	40T_TXL_2-W/OR_0.8	XC 1 D
FRONT_CHASSIS	40T_GXL_2-W/OR_0.8	EE 4 D
MAIN_CAB	40T_TXL_2-W/OR_0.8	XC 2 B
FRONT_CHASSIS	40T_TXL_2-W/OR_0.8	XC 1 A
MAIN_CAB	40T_TXL_2-W/OR_0.8	EE 4 D
MAIN_CAB	40T_TXL_2-W/OR_0.8	XC 2 C
REAR_CHASSIS_EXTENSION	40T_GXL_W/OR_1.0	EE 4 D
MAIN_CAB	40T_TXL_2-W/OR_0.8	XC 1 C
MAIN_CAB	40T_TXL_2-W/OR_0.8	XC 1 B
MAIN_CAB	40T_TXL_2-W/OR_0.8	XC 2 C
MAIN_CAB	40T_TXL_2-W/OR_0.8	XD 3 C
MAIN_CAB	40T_TXL_2-W/OR_0.8	XC 1 C
MAIN_CAB	40T_TXL_2-W/OR_0.8	XC 1 D
MAIN_CAB	40T_TXL_2-W/OR_0.8	EA 1 D
ABS_JUMPER	40T_TXL_2-W/OR_0.8	EA 1 C
ABS_JUMPER	40T_TXL_2-W/OR_0.8	EA 0 C
MAIN_CAB	40T_TXL_2-W/OR_0.8	EA 0 D
FRONT_CHASSIS	40T_GXL_2-W/OR_0.8	EA 1 B
ABS_JUMPER	40T_TXL_2-W/OR_0.8	EA 1 C
MAIN_CAB	40T_TXL_2-W/OR_0.8	EA 1 B
ABS_JUMPER	40T_TXL_2-W/OR_0.8	EA 1 C
MAIN_CAB	40T_TXL_2-W/OR_0.8	EA 1 B
FRONT_CHASSIS	40T_GXL_2-W/OR_0.8	EA 1 B

0

1

2

3

4

## COMPONENTS

COMPONENT	DESCRIPTION	PAGE
A03	Instrument cluster	BE 0 D
A03_Z	GAUGE FUEL LEVEL LNG	CG 1 B
A03D	GAUGE DIESEL LEVEL & DEF LEVEL	BE 3 D
A03E	GAUGE PYROMETER	BE 3 E
A12A	Control unit, ABS ( Anti-lock Brake Syst	EA 0 C
A12B	CONTROL UNIT, ABS (ANTI-LOCK BRAKE SYS.)	EE 0 C
A12B	CONTROL UNIT, ABS (ANTI-LOCK BRAKE SYS.)	EF 0 A
A17	Control unit, VECU (Vehicle ECU)	AC 1 A
A17	Control unit, VECU (Vehicle ECU)	BA 1 D
A17	Control unit, VECU (Vehicle ECU)	BB 0 B
A17	Control unit, VECU (Vehicle ECU)	BC 1 D
A17	Control unit, VECU (Vehicle ECU)	BD 1 C
A17	Control unit, VECU (Vehicle ECU)	BQ 1 A
A17	Control unit, VECU (Vehicle ECU)	GD 2 A
A17	Control unit, VECU (Vehicle ECU)	HA 0 D
A19EP	CONTROL UNIT ALLISON GEAR SELECTOR PRIMARY	DD 0 E
A19ES	CONTROL UNIT, ALLISON GEAR SELECTOR SECON	DE 0 D
A34	Control unit, climate unit	HA 1 A
A39	Control unit, camera	KA 0 E
A57	Control unit, Allison Transmission	DC 0 A
A57	Control unit, Allison Transmission	DD 0 D
A58	TRANSMISSION ALLISON	DC 0 D
A83	Control unit, Daytime running lights	GD 2 B
A92A	CONTROL UNIT AUX. COOLING FAN	CD 2 C
A92B	CONTROL UNIT AUX. COOLING FAN	CD 3 C
A99	Component group, transmission and retarde	DC 3 D
A124	COMPONENT GROUP, STARTER MOTOR, M04 & K65	AC 3 A
A124	COMPONENT GROUP, STARTER MOTOR, M04 & K65	AD 2 A
A125	Control unit, TGW (Telematics Gateway)	BW 1 C
A137B	Contol Module, ACM (Adblue control modu	CH 0 C
A138	PUMP UNIT, ADBLUE	CH 1 E
A153	Instrument Cluster	BG 0 C
A153A	GAUGE FUEL	BG 3 D
A153B	GAUGE PYROMETER	BG 3 E
A158	Radio	KA 2 C
A158_J1	JUMPER BATTERY FEED	KA 3 B
A158_J2	JUMPER BATTERY FEED	KA 3 C
A175A	TMC 1226 TESP	BY 1 E
A175C	CONNECTOR TMC RP 1226	BY 3 E
A215	FLASHER	GA 2 A
A216	CAMERA MONITOR	KA 1 D
A217	GAUGE LIFT AXLE PUSHER	BE 4 C
A223	CONTROL UNIT MEMORY MIRROR	ID 1 E
A424R	Display Collision Avoidance	JG 4 B
A425	Display Collision Avoidance	JG 4 B
A426	Display Object Detection	BX 0 A
B06T1	SENSOR PRIMARY AIR	BE 1 D
B06T2	SENSOR SECONDARY AIR	BE 1 D
B07	Sensor, fuel level	BE 1 D
B07A	SENSOR LNG FUEL LEVEL	CG 1 D

COMPONENT	DESCRIPTION	PAGE
B09	SENSOR TRANSMISSION TEMPERATURE	BE 2 D
B13	SENSOR WHEEL SPD LH FRT AXLE	EA 1 B
B13	SENSOR WHEEL SPD LH FRT AXLE	EE 2 B
B14	SENSOR WHEEL SPD RH FRT AXLE	EA 1 B
B14	SENSOR WHEEL SPD RH FRT AXLE	EE 1 B
B15	SENSOR WHEEL SPD LH RR RR AXLE	EA 0 D
B15	SENSOR WHEEL SPD LH RR RR AXLE	EE 0 B
B16	SENSOR WHEEL SPD RH RR RR AXLE	EA 1 D
B16	SENSOR WHEEL SPD RH RR RR AXLE	EE 4 D
B17	Sensor, wheel speed, lhs., 2:nd driven r	EA 2 E
B17	Sensor, wheel speed, lhs., 2:nd driven r	EE 1 D
B18	Sensor, wheel speed, rhs., 2:nd driven r	EA 2 E
B18	Sensor, wheel speed, rhs., 2:nd driven r	EE 2 D
B22	SENSOR OUTDOOR TEMPERATURE	BE 0 D
B22C	SENSOR AMPIENT AIR TEMP	CJ 3 E
B23A	Sensor, oil temperature, retarder	DC 3 D
B25	Sensor, accelerator pedal	BB 3 D
B25	Sensor, accelerator pedal	BQ 3 C
B25L	SENSOR, ACCELERATOR PEDAL LEFT	BB 2 D
B49	Sensor, steering angle	EF 1 E
B50	Sensor, yaw-rate	EF 2 D
B52	Sensor, water level, water separator	CA 2 E
B60LF	Loudspeaker, left front	KA 2 E
B60RF	Loudspeaker, right front	KA 2 E
B67	Rear view camera	KA 0 D
B80	Handsfree, Loudspeaker, Microphone	KA 2 C
B99	Sensor, urea quality / temp	CA 3 C
B121	Sensor, Low level washer fluid	BE 3 A
B122A	SENSOR EXHAUST TEMPERATURE CATALYST	CJ 3 D
B122B	SENSOR CATALYST OUTLET TEMP.2	CJ 3 D
B123A	SENSOR COOLANT LEVEL	CJ 2 D
B124FR	SENSOR, OIL TEMP., FRONT REAR AXLE	BE 0 E
B124RR	SENSOR, OIL TEMP. REAR REAR AXLE	BE 0 E
B133	Sensor, Air filter restriction	BE 1 A
B152	Sensor, Brake airpressure, front	EF 3 C
B153	Sensor, Brake airpressure, rear	EF 3 C
B185A	SENSOR OXYGEN OUTLET EGO	CJ 3 D
B245A	Camera, accessory	KA 0 D
B272	Sensor, Pressure Crankcase	CJ 2 E
B300B	METHANE SENSOR ENGINE	CI 1 C
B319	SENSOR ALARM CO	CI 0 D
B322	Sensor, Air Pressure, Park Brake	BA 1 E
B431	SENSOR OBJECT FRONT	BX 0 D
B432R	SENSOR OBJECT RIGHT	BX 2 D
B433L	SENSOR OBJECT LEFT	BX 2 D
B434CR	SENSOR OBJECT REAR	BX 3 D
B437	Camera, Forward Looking FLC	JG 1 B
B438	RADAR, Forward Looking FLR	JG 2 E
E11LA	Lamp, side marker light, left side 1	GD 2 E
E11LB	Lamp, side marker light, left side 2	GD 2 D

Volvo Truck Corporation

Document title  
WIRING DIAGRAM TYPE OL

Document type  
PRODUCT SCHEMATIC

Document No  
24403869

Issue  
01

Volume  
2 (2)

Page  
2 (63)

0

1

2

3

4

0

1

2

3

4

## COMPONENTS

COMPONENT	DESCRIPTION	PAGE
E11RA	Lamp, side marker light, right side 1	GD 4 D
E11RB	Lamp, side marker light, right side 2	GD 4 D
E12L	Lamp, roof position light, left	GA 3 D
E12R	Lamp, roof position light, right	GA 4 D
E14L	Lamp, beacon warning lamp	GD 2 D
E14R	Lamp, beacon warning lamp	GD 3 D
E17L	Lamp, interior light	GH 4 B
E17R	Lamp, interior light	GH 4 B
E18L	Lamp, reading light	GH 2 B
E18R	Lamp, reading light	GH 3 B
E19C	Lamp, identification light, roof, center	GA 1 E
E19L	Lamp, identification light, roof, left	GA 0 E
E19R	Lamp, identification light, roof, right	GA 1 E
E27L	Tail lamp module, left	GF 1 C
E27R	Tail lamp module, left	GF 2 C
E30L	Lamp, full- and dipped beams, left	GD 0 D
E30R	Lamp, full- and dipped beams, right	GD 1 D
E32	Climate unit	HA 1 D
E35	HVAC Unit, Heat, Ventilation and Air Cond	HA 4 D
E57	Lamp, Main switch interface	GA 4 D
E195		BX 1 D
E195F	Light, LED Strip Driver Warning	BX 1 D
EL3L	Lamp, Cab/body working light, left	GD 0 C
EL3R	Lamp, Cab/body working light, right	GD 1 C
FM3	FUSE MAIN PWR. CAB	AC 3 D
FM3_A1	MAIN CIRCUIT BREAKER	AC 4 D
G01	Battery	AB 0 D
G01	Battery	AC 3 C
G01	Battery	AD 2 B
G01	Battery	BN 0 B
G01	Battery	CH 0 B
G01	Battery	CJ 5 A
G01	Battery	KA 4 A
G02	Alternator	AC 4 B
G02	Alternator	AD 0 A
G02	Alternator	BP 0 A
H02	Horn	GQ 3 C
H02A	Horn	GQ 2 D
H02B	Horn	GQ 3 D
H03	Reverse warner, acoustic	GF 3 B
H16	METHANE FUME DETECTOR	CI 1 B
H17	METHANE DETECTION STATUS	CI 3 B
M01L	MOTOR WINDSHIELD WIPER LH	GP 3 C
M01R	MOTOR WINDSHIELD WIPER RH	GP 2 C
M02	MOTOR WS. WASHER PUMP	GP 0 C
M78L	MOTOR MIRROR LEFT SIDE	IC 0 D
M78L	MOTOR MIRROR LEFT SIDE	ID 0 B
M78R	MOTOR MIRROR RIGHT SIDE	IC 3 C
M78R	MOTOR MIRROR RIGHT SIDE	ID 3 B
M120A	MOTOR, AUX. COOLING FAN #1	CD 0 E

COMPONENT	DESCRIPTION	PAGE
M120B	MOTOR, AUX. COOLING FAN #2	CD 1 E
M121A	MOTOR AUX. COOLING FAN #1	CD 2 D
M121B	MOTOR AUX. COOLING FAN #2	CD 3 D
R01	HEATER, ENGINE PREHEAT	AD 0 A
R04	CIGAR LIGHTER	KC 3 C
R05	Heater, air dryer	FA 3 C
R05A	AIR DRYER, HEATED	FA 2 C
R05B	AIR DRYER, HEATED	FA 0 C
R08	RESISTOR, TERMINATION J1939 CAN	XA 3 A
R08	RESISTOR, TERMINATION J1939 CAN	XB 4 A
R08B	TERM RESISTOR	BY 2 B
R08D	Terminating Resistor	BX 0 C
R08E	Terminating Resistor	BX 4 C
R09	HEATER, FUEL WATER SEPARATOR	CC 1 C
R14	Termination resistor	XC 2 C
R14B	Termination resistor	XC 2 B
R19A	HEATER HEATED DRAIN VALVE COOLING TANK	FA 0 C
R19B	HEATER HEATED DRAIN VALVE WET TANK	FA 1 C
R21A	TERM RESISTOR	XE 2 B
R21B	TERM RESISTOR	XE 1 B
R29	Heater, NOxCare tank to pump hose	CH 3 E
R31	Heater, NOxCare pump to injector hose	CH 3 D
R34	Termination resistor	XB 1 E
R39A	RESISTOR, CUMMINS PULL UP IVS	BE 2 C
R39B	RESISTOR CUMMINS PULL DOWN FUEL LEVEL	BE 1 D
R78	HEATER ENGINE BLOCK COOLANT	CC 2 C
RLY63_JMP	JUMPER, CLEARANCE LIGHTS	GA 2 E
S01A	SWITCH, MAIN LIGHTING	GA 0 B
S03	Switch, loading lamps / working lamps	GD 4 A
S05A	Switch, interior light, selector type	GH 4 D
S05B	Switch, interior light, selector type	GH 2 D
S05C	Switch, interior light, selector type	GH 3 D
S07	Switch, engine brake, selector type	BA 3 C
S08	Switch, differential gear lock, rear whe	BD 1 B
S09A	Switch, differential lock, rear inter-axl	FB 4 B
S13L	SWITCH, DIRECTIONAL SIGNAL LEFT	GA 2 C
S13R	SWITCH, DIRECTIONAL SIGNAL RIGHT	GH 0 D
S14L	SWITCH, HORN LEFT SIDE	GQ 0 C
S14R	SWITCH, HORN RIGHT SIDE	GQ 1 C
S019A	SWITCH, POWER DIVIDER LOCKOUT	FB 3 B
S28A	Switch, power take off 1	FD 0 B
S28D	Switch, power take off 4	FC 1 B
S30	Switch unit, multi-function display	BE 1 B
S30A	SWITCH 1 LEFT IC DISPLAY	BE 2 A
S30B	SWITCH RIGHT ICDISPLAY	BG 1 A
S30C	SWITCH 1 RIGHT IC DISPLAY	BG 2 A
S31	Switch, TCS ( Traction Control System )	EA 2 A
S31	Switch, TCS ( Traction Control System )	EE 3 B
S40	Switch, rear view camera, camera selecti	KA 0 B
S43	Pressure switch, parking brake indicator	BA 2 E

Volvo Truck Corporation

Document title  
WIRING DIAGRAM TYPE OLDocument type  
PRODUCT SCHEMATIC

Document No

24403869

Issue

01

Volume

2 (2)

Page

3 (63)

0

1

2

3

4

0

1

2

3

4

## COMPONENTS

COMPONENT	DESCRIPTION	PAGE
S43D	SW. PRESS PARK BRAKE BODYBUILDER	BP 1 B
S44	Position switch, door, interior light, N	GH 4 E
S44L	SWITCH DOOR LEFT	GH 3 E
S48P	SWITCH PRESSURE SERVICE BRAKE PRIMARY	GA 4 B
S48PL	SWITCH SERVICE BRAKE PRIMARY N/O LEFT	DE 3 C
S48PR	SWITCH SERVICE BRAKE PRIMARY N/O RIGHT	DE 2 C
S48S	SWITCH PRESSURE SERVICE BRAKE SECONDARY	GA 4 B
S48SL	SWITCH SERVICE BRAKE SECONDARY N/O LEFT	DE 4 C
S48SR	SWITCH SERVICE BRAKE SECONDARY N/O RIGHT	DE 3 C
S54	Position switch, differential gear lock, BE	4 B
S71	Pressure switch, compressor charging, NO	HA 0 C
S103	Switch, heated mirror, mirror adjustment	IC 0 B
S103	Switch, heated mirror, mirror adjustment	ID 2 B
S105	Switch, Hazard warning light	GH 2 D
S106PS	SWITCH, PASSENGER POWER WINDOW	IE 2 B
S107	SWITCH, DRIVER POWER WINDOW	IE 0 B
S115	Switch, Door lock	IF 1 C
S117	Position switch, differential lock, rear	BE 4 B
S123	Switch, Mirror defrost	IC 2 B
S123	Switch, Mirror defrost	ID 1 B
S130	Switch, Air suspension	FB 2 B
S146	Switch, R/+ and S/-	BA 0 C
S146B	SWITCH RIGHT R/+S-	BA 1 C
S147A	Switch, RPM regulation	BA 2 C
S147B	Switch, RPM regulation	BA 3 C
S169	Switch, Battery Main Switch	AC 3 D
S190	Switch, pressure sensor / airconditioning	HA 0 D
S217	Switch, ignition, selector type (dashboar	AC 0 C
S218	Stalk switch, windshield wiper, selector	GP 0 B
S314	SWITCH, RETARDER	DD 1 B
S330	SWITCH, BODY BUILDER PARK BRAKE	BB 0 E
S330	SWITCH, BODY BUILDER PARK BRAKE	BQ 0 C
S330JMP	SWITCH, BODY BUILDER PARK BRAKE JUMPER	BB 1 E
S330JMP	SWITCH, BODY BUILDER PARK BRAKE JUMPER	BQ 2 C
S331	SWITCH, PARKER PTO ENGAGED	FD 1 C
S332	SWITCH, DIMMER	GA 1 B
S339	SWITCH, MASTER LEFT/RIGHT DRIVE	BB 0 A
S340	SWITCH, WORK BRAKE PRIMARY 1	DE 1 C
S340A	SWITCH, WORK BRAKE PRIMARY 2	DE 0 B
S340B	SWITCH WORK BRAKE SECONDARY 1	DE 1 B
S340C	SWITCH, WORK BRAKE SECONDARY 2	DE 0 B
S341A	SWITCH TAG AXLE LIFT	FB 0 C
S341B	SWITCH PUSHER AXLE LIFT	FB 0 B
S344	SWITCH PRESSURE PRIMARY LOW AIR	BF 1 C
S344A	SWITCH PRESSURE SECONDARY LOW AIR	BF 2 C
S347	SWITCH MIRROR MEMORY	ID 2 B
S493L	SWITCH BRAKE AUTO NEUTRAL LEFT	DD 0 B
S493R	SWITCH BRAKE AUTO NEUTRAL RIGHT	DD 0 B
S564F	JUMPER FRONT	BX 1 E
S564F	JUMPER FRONT	JG 2 B

COMPONENT	DESCRIPTION	PAGE
S564G	JUMPER FRONT	BX 2 A
V03	Diode	GD 1 C
V08	Diode	BA 1 B
V09	Diode	BA 2 B
V33	Diode	BF 2 C
V34	Diode	DD 3 C
V35	DIODE, METHANE DETECTION	CI 0 D
X0C	SPLICE PACK, ILLUMINATION, SEE DIAGRAM	GH BA 3 A
X0C	SPLICE PACK, ILLUMINATION, SEE DIAGRAM	GH GH 4 A
X0C	SPLICE PACK, ILLUMINATION, SEE DIAGRAM	GH HA 1 A
X01	Connector, vehicle diagnostics	XD 2 C
X01A	Connector, vehicle diagnostics 16 poles	XA 1 C
X01A	Connector, vehicle diagnostics 16 poles	XB 2 D
X01A	Connector, vehicle diagnostics 16 poles	XC 1 D
X01A	Connector, vehicle diagnostics 16 poles	XD 2 C
X06D	CONNECTOR ALLISON BODY BUILDER	BH 0 C
X07A	POWER OUTLET #1	KC 1 C
X10	B+ pass through, Cab	AC 3 E
X11	Connector, Engine	CA 0 C
X11	Connector, Engine	HA 0 E
X11B	CONNECTORS CUMMINS '18 ISL G ENGINE	CJ 1 C
X21B	Socket, Body builder connector	BC 0 C
X21F	BODYLINK TMC RP170 POWERTRAIN	BP 0 D
X21G	BODYLINK TMC RP170 LIGHTING	BN 2 C
X21H	BODYLINK TMC RP170 POWER	BN 0 C
X34	JUNCTION, CB BINDING POST	KC 2 C
X71	GROUND, ENGINE BLOCK, ALTERNATOR, PRE-HE	AD 0 D
X110	Split Connector, ground	AD 2 B
X111	Split Connector, ground	AD 4 C
X111	Split Connector, ground	BC 0 C
X111	Split Connector, ground	CI 1 D
X111	Split Connector, ground	GD 2 B
X111	Split Connector, ground	HA 1 B
X135	Chassis Ground Stud	AD 1 C
X136	Cab Passthrough Ground Stud	AD 2 C
X137	Cab Ground Stud	AD 2 C
X137A	STUD CAB GROUND	AD 2 D
X140	Battery Box Ground Stud	AD 1 B
X141	CONNECTOR SHORE POWER BLOCK HEATER	CC 2 B
X175	JUNCTION BLOCK 14 POST MAIN	GG 2 D
X175	JUNCTION BLOCK 14 POST MAIN	NA 1 A
X178	JUNCTION BLOCK 5 POST OPTIONS	NB 1 B
X179	JUNCTION BLOCK 4 POST BODY BUILDER	KA 0 C
X179	JUNCTION BLOCK 4 POST BODY BUILDER	NB 3 D
X194	CONNECTOR, TGW BODYBUILDER INTERFACE	BW 1 D
X197	CONNECTOR EATS	BE 1 A
X197	CONNECTOR EATS	CA 2 B
X197	CONNECTOR EATS	CH 0 D
Y05	Solenoid valve, bogie lift	FB 0 D
Y11	Solenoid valve unit, ABS, front left	EA 0 B

Volvo Truck Corporation

Document title  
WIRING DIAGRAM TYPE OL

Document type  
PRODUCT SCHEMATIC

Document No

24403869

Issue

01

Volume

2 (2)

Page

4 (63)

0

1

2

3

4

0

1

2

3

4

## COMPONENTS

COMPONENT	DESCRIPTION	PAGE
Y11	Solenoid valve unit, ABS, front left	EE 1 B
Y12	Solenoid valve unit, ABS, front right	EA 1 B
Y12	Solenoid valve unit, ABS, front right	EE 0 B
Y13	Solenoid valve unit, ABS, rear left	EA 1 D
Y13	Solenoid valve unit, ABS, rear left	EE 1 B
Y14	Solenoid valve unit, ABS, rear right	EA 2 D
Y14	Solenoid valve unit, ABS, rear right	EE 0 E
Y15	Solenoid valve unit, ABS, lhs. 3:rd axle	EA 3 D
Y15	Solenoid valve unit, ABS, lhs. 3:rd axle	EE 2 E
Y16	Solenoid valve unit, ABS, rhs. 3:rd axle	EA 3 D
Y16	Solenoid valve unit, ABS, rhs. 3:rd axle	EE 2 E
Y18A	Solenoid valve, PTO1 (Power Take Off)	FC 1 D
Y35	Solenoid valve, engine cooling fan	CA 1 C

COMPONENT	DESCRIPTION	PAGE
Y35E	SOLENOID ENGINE FAN E-VISCO	CJ 1 D
Y42	Clutch, magnetic, air conditioning compr	HA 0 E
Y51	Solenoid valve, Air dryer	FA 4 C
Y57	Solenoid valve, Automatic Traction Contr	EA 1 D
Y57	Solenoid valve, Automatic Traction Contr	EE 3 E
Y57C	SOLENOID VALVE SA TRACTION HSA	EF 0 C
Y62	Solenoid valve, TCM backup	DC 0 C
Y81	Solenoid valve, AdBlue tank heating	CH 2 D
Y95	SOLENOID HIGH NG PRESSURE LOCKOFF	CG 2 D
Y137	Mega valve unit	FB 1 D
Y168	SOLENOID, PARKER PTO	FD 3 C
Z10	ONBOARD DIAGNOSTIC CONNECTOR VENDOR ENGIN	XB 1 C
Z10	ONBOARD DIAGNOSTIC CONNECTOR VENDOR ENGIN	XE 3 C

Volvo Truck Corporation

Document title  
WIRING DIAGRAM TYPE OLDocument type  
PRODUCT SCHEMATIC

Document No

24403869

Issue

01

Volume

2 (2)

Page

5 (63)

0

1

2

3

4



FUSES AND CIRCUIT BREAKERS

FUSE	DESCRIPTION	PAGE
F13 (15A/20A)	FUSE ABS BATT	AA 3 B
F13 (15A/20A)	FUSE ABS BATT	EA 3 A
F13 (15A/20A)	FUSE ABS BATT	EE 2 A
F14 (30A)	FUSE, OPEN	AA 3 B
F14 (30A)	FUSE, OPEN	CD 2 A
F16 (10A)	FUSE, VECU (EMS)	AB 1 C
F16 (10A)	FUSE, VECU (EMS)	BA 0 A
F17 (10A)	FUSE, CONTROL/SW INPUTS	AB 1 C
F17 (10A)	FUSE, CONTROL/SW INPUTS	BA 2 A
F19 (5A)	FUSE INST. CLUSTER	AA 3 B
F19 (5A)	FUSE INST. CLUSTER	BE 0 A
F25 ( )	FUSE HVAC CAB	AB 4 D
F28 ( )	FUSE, ALT SENSE	AC 3 B
F31 (10A)	FUSE TRANS SPARE	AB 1 C
F31 (10A)	FUSE TRANS SPARE	DD 3 A
F38 (30A)	FUSE ENGINE CONTROL UNIT	AA 1 D
F38 (30A)	FUSE ENGINE CONTROL UNIT	CA 0 A
F41 (20A)	FUSE, ENGINE ACC.	AA 1 D
F41 (20A)	FUSE, ENGINE ACC.	CG 2 A
F43 (15A)	FUSE ENGINE COMP #2	AA 2 D
F43 (15A)	FUSE ENGINE COMP #2	CA 1 B
F48 ( )	FUSE LED DRL	GD 4 C
F49 (10A)	FUSE, ABS	AA 0 D

FUSE	DESCRIPTION	PAGE
F49 (10A)	FUSE, ABS	EA 3 A
F49 (10A)	FUSE, ABS	EE 2 A
F60 (15A)	FUSE, ENG COMP #1	AB 3 B
F60 (15A)	FUSE, ENG COMP #1	CA 0 A
F60 (15A)	FUSE, ENG COMP #1	CJ 3 A
F62 (30A)	FUSE, EAT BATT.	AB 3 B
F62 (30A)	FUSE, EAT BATT.	CD 3 A
F63 (5A)	FUSE, INSTR CLUSTER (EMS)	AB 2 C
F63 (5A)	FUSE, INSTR CLUSTER (EMS)	BE 0 A
F64 (10A)	FUSE, DPF, IGN	AB 2 C
F69 (5A)	FUSE, EAT EMS	AB 3 C
F69 (5A)	FUSE, EAT EMS	CH 0 A
F71 (10A)	FUSE, TRANS (BATT)	AB 4 B
F71 (10A)	FUSE, TRANS (BATT)	DD 0 A
F75 ( )	OBJECT SENSE/ ECS	NA 1 C
F76 ( )	FUSION	JG 2 A
F77 ( )	FUSE SPARE 3	HA 1 B
F80 (5A)	FUSE CUMMINS ECU	CJ 2 B
F81 ( )	FUSE, METHANE DETECTOR	CI 4 B
F82 ( )	TGW	BW 1 B
F84 ( )	FUSION	JG 1 A
FM5 (1A)	RCIOM power supply 1	CG 2 C

Volvo Truck Corporation

Document title  
WIRING DIAGRAM TYPE OL

Document type  
PRODUCT SCHEMATIC

Document No

24403869

Issue

01

Volume

2 (2)

Page

10 (63)

0

1

2

3

4

## INLINES

INLINE	HARNESS	PN
6SABS	REAR_CHASSIS_EXTENSION	25177271
6SABS	FRONT_CHASSIS	25177270
A230FC(1)	FRONT_CHASSIS	22183815
A230FC(2)	FRONT_CHASSIS	22183815
ABS_X1	MAIN_CAB	20737547
ABS_X1	ABS_JUMPER	21401239
ABS_X2	AUTOTRANS_ABS_CAB	20367826
ABS_X2	ABS_JUMPER	3987482
ABS_X3	MAIN_CAB	20367825
ABS_X3	ABS_JUMPER	3987481
ALLISON	AUTOTRANS_TRANS	21794150
ALLISON	FRONT_CHASSIS	21794151
B52A	FRONT_CHASSIS	8067321
B52A	FUEL_SENDER_EXT	25497124
BB_PK_BK	MAIN_CAB	25159660
BB_PK_BK	BB_PARK_BK	20897227
BBM_1939_plug	MAIN_CAB	8397678
BBM_1939_socket	MAIN_CAB	8397681
BBMJ1939_OPTA	DRIVECAM_OL	8397678
BBMJ1939_OPTA	MAIN_CAB	8397681
BBMJ1939_OPTB	MAIN_CAB	8397678
BBMJ1939_OPTB	DRIVECAM_OL	8397681
CDPF	FRONT_CHASSIS	20388115
CDPF	CNG_RH_STANTION	20388011
CNGND1	GROUND_CUMMINS	21879134
CNGND1	FRONT_CHASSIS	21879132
DL1DL1	MAIN_CAB	20414451
DL1DL1	XXX	874397
DL1PR	PRECO_ROOF	20414451
DL1PR	MAIN_CAB	874397
DPDL1_plug	DOOR_LEFT	8067321
DPDL1_socket	DOOR_LEFT	8067319
DPDL2_plug	DOOR_LEFT	8067321
DPDL2_socket	DOOR_LEFT	8067319
DPDL3_plug	DOOR_LEFT	20964476
DPDL3_socket	DOOR_LEFT	25497605
DPDL4_plug	DOOR_LEFT	20897604
DPDL4_socket	DOOR_LEFT	20964475
DPDR1_plug	DOOR_RIGHT	8067321
DPDR1_socket	DOOR_RIGHT	8067319
DPDR3_plug	DOOR_RIGHT	20964476
DPDR3_socket	DOOR_RIGHT	25497605
DPDR4_plug	DOOR_RIGHT	20897604
DPDR4_socket	DOOR_RIGHT	20964475
DPDR_plug	DOOR_RIGHT	8067321
DPDR_socket	DOOR_RIGHT	8067319
DPMC_plug	MAIN_CAB	8397837
DPMC_socket	MAIN_CAB	8397839
DSFC	REAR_CHASSIS_EXTENSION	21095816
DSFC	DS_HARNESS	25192110

INLINE	HARNESS	PN
FCALT	BB_CAB_C	25100386
FCALT	BODY_BUILDER_CHASSIS	25100395
FCAR	STANTION_HARNESS	8122616
FCAR	AIR_RESTRICTION	20378258
FCBL	FRONT_CHASSIS	8397314
FCBL	BB_CAB_C	25024035
FCCE	FRONT_CHASSIS	21794150
FCCE	REAR_CHASSIS_EXTENSION	21794151
FCEFS	FRONT_CHASSIS	8397384
FCEFS	ENGINE_FAN_HARNESS	8397382
FCFS	FRONT_CHASSIS	8122616
FCFS	FUEL_SENDER_EXT	20378258
FCFS2	FRONT_CHASSIS	8397384
FCFS2	EVISCOUS_JUMPER	8397382
FCLA	FRONT_CHASSIS	8075978
FCLA	LIFT_AXLE	8075980
FCRP170A	BB_CAB_C	23215878
FCRP170A	BB_CAB_B	23215876
FCSH	STANTION_HARNESS	20437604
FCSH	FRONT_CHASSIS	21109928
FCSP	REAR_CHASSIS_EXTENSION	20388115
FCSP	{AIR SOLENOID PACK}	20388011
FCUT	UREA_TANK_EXTENSION	21470573
FCUT	UREA_TANK	21470571
FCUTEXT	FRONT_CHASSIS	22506964
FCUTEXT	UREA_TANK_EXTENSION	21470571
FRC1	MAIN_CAB	22646267
FRC2	MAIN_CAB	25497246
FRC3	MAIN_CAB	25497246
G01_A1	CAB_POWER	20989336
G01_A4	CAB_POWER	20989336
G01_F	FRONT_CHASSIS	21153724
H02DHJ	DUAL_HORN_JUMPER	8397401
H02DHJ	FRONT_CHASSIS	25090155
HOOKUP_LP	MAIN_CAB	25159660
HOOKUP_LP	XXX	20897227
ILLUM_OPT	MAIN_CAB	8397678
ILLUM_OPT	{}	8397681
ILLUM_OPT1	MAIN_CAB	8397678
ILLUM_OPT1	LIFT_AXLE_GAUGE	8397681
ILLUM_OPT2	LIFT_AXLE_GAUGE	8397678
ILLUM_OPT2	MAIN_CAB	8397681
ILLUM_OPT6	MAIN_CAB	8397678
ILLUM_OPT6	PARKER_PTO_OVERLAY	8397681
ILLUM_OPT7	PARKER_PTO_OVERLAY	8397678
ILLUM_OPT7	MAIN_CAB	8397681
IMS	FRONT_CHASSIS	8397384
IMS	STARTER_IMS_TERMINAL	8397382
LHCS	FRONT_CHASSIS	25101063
LHCS	STANTION_HARNESS	20815300

INLINE	HARNESS	PN
LHSP	FRONT_CHASSIS	8397837
LHSP	STANTION_HARNESS	8397839
MCAF	AUX_FAN	25078072
MCAF	MAIN_CAB	25023589
MCCOD	ROOF	8067321
MCCOD	MAIN_CAB	25497124
MCCS_plug	MAIN_CAB	8397686
MCCS_socket	MAIN_CAB	8397685
MCDPL1	MAIN_CAB	8067321
MCDPL1	DOOR_LEFT	8067319
MCDPL2	DOOR_LEFT	8067321
MCDPL2	MAIN_CAB	8067319
MCDPL3	DOOR_LEFT	20964476
MCDPL3	PWR_MIRROR_CAB	25497605
MCDPL4	DOOR_LEFT	20897604
MCDPL4	PWR_MIRROR_CAB	20964475
MCDPR1	MAIN_CAB	8067321
MCDPR1	DOOR_RIGHT	8067319
MCDPR2	DOOR_RIGHT	8067321
MCDPR2	MAIN_CAB	8067319
MCDPR3	DOOR_RIGHT	20964476
MCDPR3	PWR_MIRROR_CAB	25497605
MCDPR4	DOOR_RIGHT	20897604
MCDPR4	PWR_MIRROR_CAB	20964475
MCDSL	MAIN_CAB	8397678
MCDSL	DOOR_SWITCH_LEFT	8397681
MCDSR	MAIN_CAB	8397678
MCDSR	DOOR_SWITCH_RIGHT	8397681
MCFC	MAIN_CAB	21470537
MCFC	FRONT_CHASSIS	21771075
MCFC2	MAIN_CAB	25177198
MCFC2	FRONT_CHASSIS	25177196
MCFG	FUEL_GAUGE_JUMPER	8075754
MCFG	MAIN_CAB	8075755
MCHVAC	MAIN_CAB	20722781
MCHVAC1_plug	MAIN_CAB	22260611
MCHVAC1_socket	MAIN_CAB	22260613
MCHVAC2_plug	MAIN_CAB	20367824
MCHVAC2_socket	MAIN_CAB	3987480
MCHVAC3_plug	MAIN_CAB	21084327
MCHVAC3_socket	MAIN_CAB	21123497
MCMD	ROOF	20964476
MCMD	MAIN_CAB	25497605
MCMIR_plug	MAIN_CAB	8397401
MCMIR_socket	MAIN_CAB	8397402
MCMIRMEM_plug	MAIN_CAB	8397401
MCMIRMEM_socket	MAIN_CAB	8397402
MCPM1	MAIN_CAB	21400841
MCPM1	PWR_MIRROR_CAB	21400731
MCPM2	MAIN_CAB	8397342

Volvo Truck Corporation

Document title  
WIRING DIAGRAM TYPE OLDocument type  
PRODUCT SCHEMATIC

Document No

24403869

Issue

01

Volume

2 (2)

Page

8 (63)

0

1

2

3

4

INLINES

INLINE	HARNESS	PN
MCPM2	PWR_MIRROR_CAB	8397343
MCPRF	PRECO_ROOF	874404
MCPRF	MAIN_CAB	874405
MCPSC1	STEERING_COLUMN	21401238
MCPSC1	MAIN_CAB	21401216
MCPSC2	STEERING_COLUMN	22040863
MCPSC2	MAIN_CAB	22040862
MCPSC3	STEERING_COLUMN	22040864
MCPSC3	MAIN_CAB	22040861
MCRC	MAIN_CAB	8397342
MCRC	REAR_CONSOLE	8397343
MCRF1	MAIN_CAB	8397422
MCRF1	ROOF	8397416
MCRF2	MAIN_CAB	8397342
MCRF2	ROOF	8397343
MCRF3	MAIN_CAB	8397348
MCRF3	ROOF	8397349
MCRFC_plug	ROOF	20824322
MCRFC_socket	ROOF	20824324
MCRP170A	MAIN_CAB	23215878
MCRP170A	BB_CAB_B	23215876
MCRRM_plug	MAIN_CAB	8397686
MCRRM_socket	MAIN_CAB	8397685
MCS01	SWITCH_OVERLAY	22082341

INLINE	HARNESS	PN
MCS01	MAIN_CAB	22082345
MCS02	SWITCH_OVERLAY	22082343
MCS02	MAIN_CAB	22082346
MCSSC1	STEERING_COLUMN	21401238
MCSSC1	MAIN_CAB	21401216
MCSSC2	STEERING_COLUMN	22040863
MCSSC2	MAIN_CAB	22040862
MCTL	REAR_CHASSIS_EXTENSION	8397314
MCTL	TAIL_LAMP	25024035
MCWB1	WASHER_BOTTLE	8397678
MCWB1	MAIN_CAB	8397681
MCWB2	MAIN_CAB	8397678
MCWB2	WASHER_BOTTLE	8397681
PMCPR	PRECO_ROOF	21015672
PMCPR	MAIN_CAB	21015673
PPCO	MAIN_CAB	8075978
PPCO	PARKER_PTO_OVERLAY	8075980
PRCFC	PRECO_REAR	992170
PRCFC	FRONT_CHASSIS	992167
PSCTS	STEERING_COLUMN	3186493
PSCTS	MAIN_CAB	20378994
RC1	MAIN_CAB	25168565
RC2	MAIN_CAB	25168565
RC6	MAIN_CAB	25168565

INLINE	HARNESS	PN
RCOLAY	DRIVECAM_OL	20735002
RCOLAY	MAIN_CAB	20735004
RFHL	ROOF	8397422
RFHL	HEADLINER	8397416
RFMIC	MAIN_CAB	982165
RFMIC	ROOF	20377693
RLY35_plug	MAIN_CAB	8098092
RLY89_plug	MAIN_CAB	8098092
SP_BAT1	MAIN_CAB	8397401
SP_BAT1	{}	8397402
SP_FUSE	MAIN_CAB	8397345
SP_FUSE	{}	8397350
SP_IGN1	MAIN_CAB	25159660
SP_IGN1	AUX_FAN	20897227
SP_IGN2	MAIN_CAB	8397401
SP_IGN2	BB_CAB_A	8397402
SP_RLY	MAIN_CAB	8397422
SP_RLY	BB_CAB_A	8397416
SSCTS	STEERING_COLUMN	20378994
SSCTS	MAIN_CAB	3186493
TRPTO	PTO	8397385
TRPTO	AUTOTRANS_TRANS	8397383
WL	MAIN_CAB	8397348
WL	WORKLAMP_ROOF	8397349

Volvo Truck Corporation

Document title  
WIRING DIAGRAM TYPE OL

Document type  
PRODUCT SCHEMATIC

Document No  
24403869

Issue  
01

Volume  
2 (2)

Page  
9 (63)

## REFERENCES

REF	DESCRIPTION	PAGE
6SABS:A		EA 2 D
6SABS:A		EE 1 D
6SABS:B		EA 2 D
6SABS:B		EE 1 D
6SABS:C		EA 2 D
6SABS:C		EE 2 D
6SABS:D		EA 2 D
6SABS:D		EE 2 D
6SABS:E		EA 3 D
6SABS:E		EE 2 D
6SABS:F		EA 3 E
6SABS:F		EE 2 D
6SABS:G		EA 3 D
6SABS:G		EE 2 D
6SABS:H		EA 3 D
6SABS:H		EE 2 D
6SABS:J		EA 4 E
6SABS:J		EE 2 D
6SABS:K		EA 3 D
6SABS:K		EE 3 D
A03	Instrument cluster	BE 0 D
A03_Z	GAUGE FUEL LEVEL LNG	CG 1 B
A03D	GAUGE DIESEL LEVEL & DEF LEVEL	BE 3 D
A03E	GAUGE PYROMETER	BE 3 E
A12A	Control unit, ABS ( Anti-lock Brake Syst	EA 0 C
A12B	CONTROL UNIT, ABS (ANTI-LOCK BRAKE SYS.)	EE 0 C
A12B	CONTROL UNIT, ABS (ANTI-LOCK BRAKE SYS.)	EF 0 A
A17	Control unit, VECU (Vehicle ECU)	AC 1 A
A17	Control unit, VECU (Vehicle ECU)	BA 1 D
A17	Control unit, VECU (Vehicle ECU)	BB 0 B
A17	Control unit, VECU (Vehicle ECU)	BC 1 D
A17	Control unit, VECU (Vehicle ECU)	BD 1 C
A17	Control unit, VECU (Vehicle ECU)	BQ 1 A
A17	Control unit, VECU (Vehicle ECU)	GD 2 A
A17	Control unit, VECU (Vehicle ECU)	HA 0 D
A19EP	CONTROL UNIT ALLISON GEAR SELECTOR PRIMARY	DD 0 E
A19ES	CONTROL UNIT, ALLISON GEAR SELECTOR SECON	DE 0 D
A34	Control unit, climate unit	HA 1 A
A39	Control unit, camera	KA 0 E
A57	Control unit, Allison Transmission	DC 0 A
A57	Control unit, Allison Transmission	DD 0 D
A58	TRANSMISSION ALLISON	DC 0 D
A83	Control unit, Daytime running lights	GD 2 B
A92A	CONTROL UNIT AUX. COOLING FAN	CD 2 C
A92B	CONTROL UNIT AUX. COOLING FAN	CD 3 C
A99	Component group, transmission and retarde	DC 3 D
A124	COMPONENT GROUP, STARTER MOTOR, M04 & K65	AC 3 A
A124	COMPONENT GROUP, STARTER MOTOR, M04 & K65	AD 2 A
A125	Control unit, TGW (Telematics Gateway)	BW 1 C
A137B	Contol Module, ACM (Adblue control modu	CH 0 C

Volvo Truck Corporation

Document title  
WIRING DIAGRAM TYPE OLDocument type  
PRODUCT SCHEMATIC

Document No

24403869

Issue

01

Volume

2 (2)

Page

14 (63)

0

1

2

3

4

## REFERENCES

REF	DESCRIPTION	PAGE
A138	PUMP UNIT, ADBLUE	CH 1 E
A153	Instrument Cluster	BG 0 C
A153A	GAUGE FUEL	BG 3 D
A153B	GAUGE PYROMETER	BG 3 E
A158	Radio	KA 2 C
A158_J1	JUMPER BATTERY FEED	KA 3 B
A158_J2	JUMPER BATTERY FEED	KA 3 C
A175A	TMC 1226 TESP	BY 1 E
A175C	CONNECTOR TMC RP 1226	BY 3 E
A215	FLASHER	GA 2 A
A216	CAMERA MONITOR	KA 1 D
A217	GAUGE LIFT AXLE PUSHER	BE 4 C
A223	CONTROL UNIT MEMORY MIRROR	ID 1 E
A230	FUSE HOLDER W COVER	AB 0 D
A230	FUSE HOLDER W COVER	CJ 4 B
A230	FUSE HOLDER W COVER	KA 4 B
A230A	FUSE HOLDER 4 FUSES	BN 1 B
A230A	FUSE HOLDER 4 FUSES	CH 0 A
A230FC:1		BN 1 B
A230FC:2		AB 0 D
A230FC:3		CH 0 B
A230FC:3		CJ 4 B
A230FC:4		KA 4 B
A424R	Display Collision Avoidance	JG 4 B
A425	Display Collision Avoidance	JG 4 B
A426	Display Object Detection	BX 0 A
ABS_X1:1		EA 2 B
ABS_X1:3		EA 3 B
ABS_X1:4		EA 1 C
ABS_X1:5		EA 1 C
ABS_X1:6		EA 2 B
ABS_X1:7		EA 3 B
ABS_X1:8		EA 4 B
ABS_X1:10		EA 1 C
ABS_X1:11		EA 1 C
ABS_X1:16		EA 3 B
ABS_X2:1		EA 1 B
ABS_X2:2		EA 0 B
ABS_X2:3		EA 0 A
ABS_X2:4		EA 1 B
ABS_X2:5		EA 1 B
ABS_X2:6		EA 1 A
ABS_X2:7		EA 1 B
ABS_X2:8		EA 1 B
ABS_X2:9		EA 0 D
ABS_X2:10		EA 2 C
ABS_X2:11		EA 1 B
ABS_X2:12		EA 0 D
ABS_X2:13		EA 1 C
ABS_X2:14		EA 1 B

Volvo Truck Corporation

Document title  
WIRING DIAGRAM TYPE OLDocument type  
PRODUCT SCHEMATIC

Document No

24403869

Issue

01

Volume

2 (2)

Page

15 (63)

0

1

2

3

4

0

1

2

3

4

## REFERENCES

REF	DESCRIPTION	PAGE
ABS_X2:15		EA 0 C
ABS_X2:16		EA 1 C
ABS_X2:17		EA 1 C
ABS_X2:18		EA 1 C
ABS_X3:4		EA 3 C
ABS_X3:6		EA 4 E
ABS_X3:7		EA 3 C
ABS_X3:9		EA 3 E
ABS_X3:10		EA 3 C
ABS_X3:11		EA 2 C
ABS_X3:12		EA 2 C
ABS_X3:13		EA 3 C
ABS_X3:14		EA 2 C
ABS_X3:15		EA 2 C
ALLISON:1		DC 2 C
ALLISON:2		DC 2 C
ALLISON:3		DC 1 C
ALLISON:4		DC 2 C
ALLISON:5		DC 0 B
ALLISON:6		DC 1 C
ALLISON:7		DC 1 C
ALLISON:8		DC 1 C
ALLISON:9		DC 1 C
ALLISON:10		DC 0 C
ALLISON:11		DC 0 C
ALLISON:12		DC 1 C
ALLISON:13		DC 1 C
ALLISON:14		DC 2 C
ALLISON:15		DC 2 C
ALLISON:16		DC 2 C
ALLISON:17		DC 0 C
ALLISON:18		DC 0 C
ALLISON:19		DC 1 C
ALLISON:20		DC 1 C
ALLISON:21		DC 2 C
ALLISON:22		DC 2 C
ALLISON:23		DC 2 C
ALLISON:24		DC 1 C
ALLISON:27		DC 0 B
ALLISON:28		BE 2 D
ALLISON:29		BE 2 E
ALLISON:30		DC 0 C
ALLISON:31		DC 0 C
ALLISON:32		FD 1 B
ALLISON:33		FD 1 C
ALLISON:34		FD 2 E
B06T1	SENSOR PRIMARY AIR	BE 1 D
B06T2	SENSOR SECONDARY AIR	BE 1 D
B07	Sensor, fuel level	BE 1 D
B07A	SENSOR LNG FUEL LEVEL	CG 1 D

Volvo Truck Corporation

Document title  
WIRING DIAGRAM TYPE OL

Document No

Issue

Volume

Page

Document type  
PRODUCT SCHEMATIC

24403869

01

2 (2)

16 (63)

0

1

2

3

4

0

1

2

3

4

## REFERENCES

REF	DESCRIPTION	PAGE
B09	SENSOR TRANSMISSION TEMPERATURE	BE 2 D
B13	SENSOR WHEEL SPD LH FRT AXLE	EA 1 B
B13	SENSOR WHEEL SPD LH FRT AXLE	EE 2 B
B14	SENSOR WHEEL SPD RH FRT AXLE	EA 1 B
B14	SENSOR WHEEL SPD RH FRT AXLE	EE 1 B
B15	SENSOR WHEEL SPD LH RR RR AXLE	EA 0 D
B15	SENSOR WHEEL SPD LH RR RR AXLE	EE 0 B
B16	SENSOR WHEEL SPD RH RR RR AXLE	EA 1 D
B16	SENSOR WHEEL SPD RH RR RR AXLE	EE 4 D
B17	Sensor, wheel speed, lhs., 2:nd driven r	EA 2 E
B17	Sensor, wheel speed, lhs., 2:nd driven r	EE 1 D
B18	Sensor, wheel speed, rhs., 2:nd driven r	EA 2 E
B18	Sensor, wheel speed, rhs., 2:nd driven r	EE 2 D
B22	SENSOR OUTDOOR TEMPERATURE	BE 0 D
B22C	SENSOR AMBIENT AIR TEMP	CJ 3 E
B23A	Sensor, oil temperature, retarder	DC 3 D
B25	Sensor, accelerator pedal	BB 3 D
B25	Sensor, accelerator pedal	BQ 3 C
B25L	SENSOR, ACCELERATOR PEDAL LEFT	BB 2 D
B49	Sensor, steering angle	EF 1 E
B50	Sensor, yaw-rate	EF 2 D
B52	Sensor, water level, water separator	CA 2 E
B52A:1		CA 2 D
B52A:2		CA 2 D
B60LF	Loudspeaker, left front	KA 2 E
B60RF	Loudspeaker, right front	KA 2 E
B67	Rear view camera	KA 0 D
B80	Handsfree, Loudspeaker, Microphone	KA 2 C
B99	Sensor, urea quality / temp	CA 3 C
B121	Sensor, Low level washer fluid	BE 3 A
B122A	SENSOR EXHAUST TEMPERATURE CATALYST	CJ 3 D
B122B	SENSOR CATALYST OUTLET TEMP.2	CJ 3 D
B123A	SENSOR COOLANT LEVEL	CJ 2 D
B124FR	SENSOR, OIL TEMP., FRONT REAR AXLE	BE 0 E
B124RR	SENSOR, OIL TEMP. REAR REAR AXLE	BE 0 E
B133	Sensor, Air filter restriction	BE 1 A
B152	Sensor, Brake airpressure, front	EF 3 C
B153	Sensor, Brake airpressure, rear	EF 3 C
B185A	SENSOR OXYGEN OUTLET EGO	CJ 3 D
B245A	Camera, accessory	KA 0 D
B272	Sensor, Pressure Crankcase	CJ 2 E
B300B	METHANE SENSOR ENGINE	CI 1 C
B319	SENSOR ALARM CO	CI 0 D
B322	Sensor, Air Pressure, Park Brake	BA 1 E
B431	SENSOR OBJECT FRONT	BX 0 D
B432R	SENSOR OBJECT RIGHT	BX 2 D
B433L	SENSOR OBJECT LEFT	BX 2 D
B434CR	SENSOR OBJECT REAR	BX 3 D
B437	Camera, Forward Looking FLC	JG 1 B
B438	RADAR, Forward Looking FLR	JG 2 E

Volvo Truck Corporation

Document title  
WIRING DIAGRAM TYPE OLDocument type  
PRODUCT SCHEMATIC

Document No

24403869

Issue

01

Volume

2 (2)

Page

17 (63)

0

1

2

3

4

0

1

2

3

4

## REFERENCES

REF	DESCRIPTION	PAGE
BB_PK_BK:A		BB 1 E
BB_PK_BK:A		BQ 1 C
BB_PK_BK:B		BB 1 E
BB_PK_BK:B		BQ 1 C
BBM_1939:A		BB 1 D
BBM_1939:B		BB 1 D
BBMJ1939_OPTA:A		BY 2 B
BBMJ1939_OPTA:B		BY 2 B
BBMJ1939_OPTB:A		BY 2 A
BBMJ1939_OPTB:B		BY 2 A
CB2	CIR. BRKR., HDLMPS. HI, DRL	AA 0 B
CB2	CIR. BRKR., HDLMPS. HI, DRL	GA 1 A
CB3	CIR. BRKR., PARK, TAIL MARKER LPS.	AA 0 B
CB3	CIR. BRKR., PARK, TAIL MARKER LPS.	GA 0 A
CB4	CIR. BRKR., TURN LPS. FLASHER	AA 1 B
CB4	CIR. BRKR., TURN LPS. FLASHER	GA 2 A
CB5	CIRCUIT BREAKER, TRACTOR STOP LPS.	AA 1 B
CB5	CIRCUIT BREAKER, TRACTOR STOP LPS.	GA 4 A
CB6	CIRCUIT BREAKER, DOME COURTESY LPS.	AA 1 B
CB6	CIRCUIT BREAKER, DOME COURTESY LPS.	GH 3 A
CB7	CIRCUIT BREAKER, KEY SW.	AA 1 B
CB7	CIRCUIT BREAKER, KEY SW.	AC 0 A
CB8	CIR. BRKR., AIR SOL.	AA 0 C
CB8	CIR. BRKR., AIR SOL.	FB 2 A
CB9	CIR. BRKR., CB POST	AA 2 B
CB9	CIR. BRKR., CB POST	KC 2 A
CB10	CIR. BRKR., DIAG. CONN.	AA 2 B
CB10	CIR. BRKR., DIAG. CONN.	KA 3 A
CB10	CIR. BRKR., DIAG. CONN.	XA 2 A
CB10	CIR. BRKR., DIAG. CONN.	XB 2 A
CB11	CIR. BRKR., BATT. STUD	AA 2 B
CB11	CIR. BRKR., BATT. STUD	BY 1 B
CB11	CIR. BRKR., BATT. STUD	GG 1 A
CB11	CIR. BRKR., BATT. STUD	NA 0 A
CB12	CIR. BRKR., OPTION BLOCK	AA 2 B
CB12	CIR. BRKR., OPTION BLOCK	NB 1 A
CB15	CIR. BRKR., BEACON LAMPS	AA 3 B
CB15	CIR. BRKR., BEACON LAMPS	FC 1 A
CB18	CIR. BRKR. DCL(CDS) EMS POWER	AB 1 C
CB18	CIR. BRKR. DCL(CDS) EMS POWER	BC 2 A
CB20	CIR. BRKR., MOTO. MIRRORS	AA 4 B
CB20	CIR. BRKR., MOTO. MIRRORS	IC 0 A
CB20	CIR. BRKR., MOTO. MIRRORS	ID 2 A
CB21	CIR. BRKR., LH WS WIPER	AA 0 C
CB21	CIR. BRKR., LH WS WIPER	GP 4 A
CB22	CIR. BRKR., RH WS WIPER	AA 0 C
CB22	CIR. BRKR., RH WS WIPER	GP 2 A
CB23	CIR. BRKR., WS WIPER/ WASHER	AA 1 C
CB23	CIR. BRKR., WS WIPER/ WASHER	GP 0 A
CB24	CIR. BRKR., 2WAY RADIO	AA 1 C

Volvo Truck Corporation

Document title  
WIRING DIAGRAM TYPE OLDocument type  
PRODUCT SCHEMATIC

Document No

24403869

Issue

01

Volume

2 (2)

Page

18 (63)

0

1

2

3

4



0

1

2

3

4

## REFERENCES

REF	DESCRIPTION	PAGE
CB24	CIR. BRKR., 2WAY RADIO	NB 0 A
CB26	CIR. BRKR., REAR FLOOD LPS.	AA 4 B
CB26	CIR. BRKR., REAR FLOOD LPS.	NA 2 A
CB27	CIR. BRKR., IGN. STUD	AA 1 C
CB27	CIR. BRKR., IGN. STUD	GG 1 A
CB27	CIR. BRKR., IGN. STUD	NA 0 A
CB29	CIR. BRKR., EMS RELAYS	AA 4 B
CB30	CIR. BRKR., MUNCIE LIVE PACK	AA 1 C
CB30	CIR. BRKR., MUNCIE LIVE PACK	FC 1 A
CB32	CIR. BRKR., BODYBUILDER BATT 2	AB 0 B
CB32	CIR. BRKR., BODYBUILDER BATT 2	NA 3 A
CB33	CIR. BRKR., TRAILER STOP LPS.	AB 0 B
CB33	CIR. BRKR., TRAILER STOP LPS.	GG 3 A
CB34	CIR. BRKR., REV/NEUTRAL POWER	AB 1 B
CB34	CIR. BRKR., REV/NEUTRAL POWER	NB 3 A
CB35	CIR. BRKR., CAB & TRLR. CLEARANCE LPS.	AB 1 B
CB35	CIR. BRKR., CAB & TRLR. CLEARANCE LPS.	GA 2 A
CB36	CIR. BRKR. HORN	AB 1 B
CB36	CIR. BRKR. HORN	GQ 3 A
CB37	CIR. BRKR., TRLR. TAIL LPS.	AB 2 B
CB37	CIR. BRKR., TRLR. TAIL LPS.	GG 2 A
CB39	CIR. BRKR., TRAILER ABS PWR	AA 1 D
CB39	CIR. BRKR., TRAILER ABS PWR	GG 1 A
CB40	CIR. BRKR., BODY IGN. PWR. STUD	AA 4 D
CB40	CIR. BRKR., BODY IGN. PWR. STUD	NB 1 A
CB42	CIR. BRKR., BACKUP LPS.	AA 4 D
CB42	CIR. BRKR., BACKUP LPS.	DD 4 A
CB44	CIR. BRKR., HTD. AIR DRYER /HTD. DRAIN VA	AA 4 D
CB44	CIR. BRKR., HTD. AIR DRYER /HTD. DRAIN VA	FA 2 A
CB45	CIR. BRKR., SPARE/FUEL SEPARATOR FUEL HEA	AA 3 D
CB45	CIR. BRKR., SPARE/FUEL SEPARATOR FUEL HEA	NB 2 A
CB46	CIR. BRKR., POWER OUTLET	AA 1 D
CB46	CIR. BRKR., POWER OUTLET	KC 1 A
CB47	CIR. BRKR., TRANS./ SPARE	AA 0 D
CB47	CIR. BRKR., TRANS./ SPARE	NA 3 A
CB50	CIR. BRKR., HDLP LH LOW BEAM	AB 2 B
CB50	CIR. BRKR., HDLP LH LOW BEAM	GD 0 A
CB51	CIR. BRKR., HDLP RH LOW BEAM	AB 2 B
CB51	CIR. BRKR., HDLP RH LOW BEAM	GD 1 A
CB52	CIR. BRKR., SPARE/ BRK. WEAR	AA 3 D
CB52	CIR. BRKR., SPARE/ BRK. WEAR	HA 0 A
CB54	CIR BRKR, DAYTIME RUNNING LIGHTS	AB 2 B
CB54	CIR BRKR, DAYTIME RUNNING LIGHTS	GD 3 A
CB55	CIR. BRKR., HEATED MIRRORS	AA 3 D
CB55	CIR. BRKR., HEATED MIRRORS	IC 2 A
CB55	CIR. BRKR., HEATED MIRRORS	ID 1 A
CB56	POWER WINDOW DRIVERS SIDE	AA 3 D
CB56	POWER WINDOW DRIVERS SIDE	IE 0 A
CB57	POWER WINDOW PASSENGER SIDE	AA 2 D
CB57	POWER WINDOW PASSENGER SIDE	IE 1 A

Volvo Truck Corporation

Document title  
WIRING DIAGRAM TYPE OLDocument type  
PRODUCT SCHEMATIC

Document No

24403869

Issue

01

Volume

2 (2)

Page

19 (63)

0

1

2

3

4

0

1

2

3

4

## REFERENCES

REF	DESCRIPTION	PAGE
CB58	CIR. BRKR. L-R RELAY CRTL.	AA 0 D
CB58	CIR. BRKR. L-R RELAY CRTL.	BB 2 A
CB61	CIR. BRKR., BODY BATT. STUD	AB 3 B
CB61	CIR. BRKR., BODY BATT. STUD	NB 0 A
CB65	CIR. BRKR., OPEN	AB 2 C
CB66	CIR. BRKR. SPARE	AA 2 C
CB66	CIR. BRKR. SPARE	KA 1 A
CB66	CIR. BRKR. SPARE	NA 4 A
CB67	CIR. BRKR., OPEN	AB 3 B
CB67	CIR. BRKR., OPEN	IF 0 A
CB68	CIR. BRKR., CIGAR LIGHTER	AB 4 B
CB68	CIR. BRKR., CIGAR LIGHTER	KC 3 A
CB74	CIR. BRKR., RADIO MEMORY	KA 3 B
CB91	CIR. BRKR., AUX FAN #1	CD 0 B
CB92	CIR. BRKR., AUX FAN #2	CD 1 B
CDPF:A		CJ 3 D
CDPF:B		CJ 4 D
CDPF:D		CJ 4 D
CDPF:E		CJ 3 D
CDPF:F		CJ 3 E
CDPF:G		CJ 4 D
CDPF:K		CJ 3 D
CDPF:L		CJ 3 D
CNGND1:1		AD 0 D
d1_Lighting_V1		FD 2 C
DL1DL1:1		XA 4 D
DL1DL1:2		XA 4 D
DL1DL1:3		XA 4 D
DL1DL1:4		XA 4 D
DL1PR:1		XA 4 D
DL1PR:2		XA 4 D
DL1PR:3		XA 4 D
DL1PR:4		XA 4 D
DPDL1:1		IF 2 D
DPDL1:2		IF 3 D
DPDL2:1		IE 0 D
DPDL2:2		IE 0 D
DPDL3:1		IC 0 D
DPDL3:1		ID 0 C
DPDL3:2		IC 1 D
DPDL3:2		ID 0 C
DPDL3:3		IC 0 D
DPDL3:3		ID 0 C
DPDL3:4		IC 0 D
DPDL3:4		ID 0 C
DPDL4:1		IC 0 D
DPDL4:1		ID 0 C
DPDL4:3		ID 0 C
DPDL4:5		ID 0 C
DPDL4:6		ID 0 C

Volvo Truck Corporation

Document title  
WIRING DIAGRAM TYPE OLDocument type  
PRODUCT SCHEMATIC

Document No

24403869

Issue

01

Volume

2 (2)

Page

20 (63)

0

1

2

3

4

## REFERENCES

REF	DESCRIPTION	PAGE
DPDR1:1		IF 2 C
DPDR1:2		IF 3 C
DPDR3:1		IC 1 D
DPDR3:1		ID 4 C
DPDR3:2		IC 1 D
DPDR3:2		ID 4 C
DPDR3:3		IC 1 D
DPDR3:3		ID 3 C
DPDR3:4		IC 1 D
DPDR3:4		ID 4 C
DPDR4:1		IC 1 D
DPDR4:1		ID 4 C
DPDR4:3		ID 4 C
DPDR4:5		ID 4 C
DPDR4:6		ID 4 C
DPDR:1		IE 1 D
DPDR:2		IE 2 D
DPMC:A		KA 4 A
DPMC:B		KA 4 A
DSFC:A		BE 0 D
DSFC:B		BE 0 E
DSFC:C		BE 0 D
DSFC:D		BE 4 B
DSFC:E		BE 4 B
E11LA	Lamp, side marker light, left side 1	GD 2 E
E11LB	Lamp, side marker light, left side 2	GD 2 D
E11RA	Lamp, side marker light, right side 1	GD 4 D
E11RB	Lamp, side marker light, right side 2	GD 4 D
E12L	Lamp, roof position light, left	GA 3 D
E12R	Lamp, roof position light, right	GA 4 D
E14L	Lamp, beacon warning lamp	GD 2 D
E14R	Lamp, beacon warning lamp	GD 3 D
E17L	Lamp, interior light	GH 4 B
E17R	Lamp, interior light	GH 4 B
E18L	Lamp, reading light	GH 2 B
E18R	Lamp, reading light	GH 3 B
E19C	Lamp, identification light, roof, center	GA 1 E
E19L	Lamp, identification light, roof, left	GA 0 E
E19R	Lamp, identification light, roof, right	GA 1 E
E27L	Tail lamp module, left	GF 1 C
E27R	Tail lamp module, left	GF 2 C
E30L	Lamp, full- and dipped beams, left	GD 0 D
E30R	Lamp, full- and dipped beams, right	GD 1 D
E32	Climate unit	HA 1 D
E35	HVAC Unit, Heat, Ventilation and Air Cond	HA 4 D
E57	Lamp, Main switch interface	GA 4 D
E195		BX 1 D
E195F	Light, LED Strip Driver Warning	BX 1 D
EL3L	Lamp, Cab/body working light, left	GD 0 C
EL3R	Lamp, Cab/body working light, right	GD 1 C

Volvo Truck Corporation

Document title  
WIRING DIAGRAM TYPE OLDocument type  
PRODUCT SCHEMATIC

Document No

24403869

Issue

01

Volume

2 (2)

Page

21 (63)

0

1

2

3

4

## REFERENCES

REF	DESCRIPTION	PAGE
F13	FUSE ABS BATT	AA 3 B
F13	FUSE ABS BATT	EA 3 A
F13	FUSE ABS BATT	EE 2 A
F14	FUSE, OPEN	AA 3 B
F14	FUSE, OPEN	CD 2 A
F16	FUSE, VECU (EMS)	AB 1 C
F16	FUSE, VECU (EMS)	BA 0 A
F17	FUSE, CONTROL/SW INPUTS	AB 1 C
F17	FUSE, CONTROL/SW INPUTS	BA 2 A
F19	FUSE INST. CLUSTER	AA 3 B
F19	FUSE INST. CLUSTER	BE 0 A
F25	FUSE HVAC CAB	AB 4 D
F28	FUSE, ALT SENSE	AC 3 B
F31	FUSE TRANS SPARE	AB 1 C
F31	FUSE TRANS SPARE	DD 3 A
F38	FUSE ENGINE CONTROL UNIT	AA 1 D
F38	FUSE ENGINE CONTROL UNIT	CA 0 A
F41	FUSE, ENGINE ACC.	AA 1 D
F41	FUSE, ENGINE ACC.	CG 2 A
F43	FUSE ENGINE COMP #2	AA 2 D
F43	FUSE ENGINE COMP #2	CA 1 B
F48	FUSE LED DRL	GD 4 C
F49	FUSE, ABS	AA 0 D
F49	FUSE, ABS	EA 3 A
F49	FUSE, ABS	EE 2 A
F60	FUSE, ENG COMP #1	AB 3 B
F60	FUSE, ENG COMP #1	CA 0 A
F60	FUSE, ENG COMP #1	CJ 3 A
F62	FUSE, EAT BATT.	AB 3 B
F62	FUSE, EAT BATT.	CD 3 A
F63	FUSE, INSTR CLUSTER (EMS)	AB 2 C
F63	FUSE, INSTR CLUSTER (EMS)	BE 0 A
F64	FUSE, DPF, IGN	AB 2 C
F69	FUSE, EAT EMS	AB 3 C
F69	FUSE, EAT EMS	CH 0 A
F71	FUSE, TRANS (BATT)	AB 4 B
F71	FUSE, TRANS (BATT)	DD 0 A
F75	OBJECT SENSE/ ECS	NA 1 C
F76	FUSION	JG 2 A
F77	FUSE SPARE 3	HA 1 B
F80	FUSE CUMMINS ECU	CJ 2 B
F81	FUSE, METHANE DETECTOR	CI 4 B
F82	TGW	BW 1 B
F84	FUSION	JG 1 A
FCAD:A		FA 0 B
FCAD:A		FA 0 B
FCAD:B		FA 0 D
FCAD:B		FA 0 C
FCALT:A		BP 0 B
FCAR:A		BE 1 B

Volvo Truck Corporation

Document title  
WIRING DIAGRAM TYPE OLDocument type  
PRODUCT SCHEMATIC

Document No

24403869

Issue

01

Volume

2 (2)

Page

22 (63)

0

1

2

3

4

0

1

2

3

4

## REFERENCES

REF	DESCRIPTION	PAGE
FCAR:B		BE 0 A
FCBL:A		GF 2 B
FCBL:B		GF 1 B
FCBL:C		BN 2 C
FCBL:C		GF 1 B
FCBL:D		BN 2 C
FCBL:D		GF 2 B
FCBL:E		GF 2 B
FCCE:2		FB 2 D
FCCE:4		FB 1 C
FCCE:7		GF 2 B
FCCE:11		GF 2 D
FCCE:12		FB 1 D
FCCE:14		GF 2 D
FCCE:15		EA 0 D
FCCE:15		EE 0 B
FCCE:16		EA 1 D
FCCE:16		EE 0 B
FCCE:17		EA 1 D
FCCE:17		EE 1 B
FCCE:18		EA 1 E
FCCE:18		EE 1 B
FCCE:19		EA 1 D
FCCE:19		EE 1 B
FCCE:20		EA 1 D
FCCE:20		EE 4 D
FCCE:21		EA 1 D
FCCE:21		EE 4 D
FCCE:22		EA 1 D
FCCE:22		EE 0 D
FCCE:23		EA 1 E
FCCE:23		EE 0 D
FCCE:24		EA 2 D
FCCE:24		EE 0 D
FCCE:25		EA 1 D
FCCE:25		EE 3 D
FCCE:26		EA 1 D
FCCE:26		EE 3 D
FCCE:27		FB 1 E
FCCE:28		BE 1 E
FCCE:29		BE 0 D
FCCE:30		BE 0 D
FCCE:31		BE 4 B
FCCE:32		BE 4 B
FCCE:33		GF 1 B
FCCE:34		GF 1 B
FCCE:35		GF 2 B
FCEFS:A		CA 1 C
FCEFS:B		CA 1 C
FCFS2:A		CJ 1 D

Volvo Truck Corporation

Document title  
WIRING DIAGRAM TYPE OLDocument type  
PRODUCT SCHEMATIC

Document No

24403869

Issue

01

Volume

2 (2)

Page

23 (63)

0

1

2

3

4

0

1

2

3

4

## REFERENCES

REF	DESCRIPTION	PAGE
FCFS2:A		CJ 1 D
FCFS2:B		CJ 1 E
FCFS2:B		CJ 1 E
FCFS:A		BE 1 D
FCFS:B		BE 1 E
FCLA:A		FB 0 D
FCLA:B		FB 0 D
FCLA:C		FB 0 E
FCRP170A:2		BN 2 C
FCRP170A:3		BP 0 C
FCRP170A:5		BN 2 C
FCRP170A:6		BN 3 C
FCRP170A:7		BN 3 C
FCRP170A:13		BN 3 C
FCRP170A:14		BN 3 C
FCSH:1		CD 0 D
FCSH:2		CD 1 D
FCSH:3		CD 0 D
FCSH:4		CD 1 D
FCSP:B		FB 1 D
FCSP:C		FB 1 D
FCSP:E		FB 2 D
FCSP:L		FB 1 E
FCSP:N		FB 3 E
FCSP:R		FB 2 E
FCSP:S		FB 1 E
FCUT:2		CH 3 D
FCUT:3		CH 4 D
FCUT:4		CH 3 D
FCUT:5		CH 1 D
FCUT:6		CH 2 D
FCUT:7		CH 2 D
FCUT:8		CH 2 D
FCUT:9		CH 2 D
FCUT:11		CA 3 C
FCUT:12		CH 2 D
FCUT:14		CA 3 C
FCUT:15		CH 1 D
FCUT:16		CH 1 D
FCUT:17		CA 3 D
FCUT:18		CA 3 D
FCUT:21		CA 3 C
FCUT:22		CA 3 C
FCUTEXT:2		CH 3 C
FCUTEXT:3		CH 4 C
FCUTEXT:4		CH 3 C
FCUTEXT:5		CH 1 C
FCUTEXT:6		CH 2 C
FCUTEXT:7		CH 2 C
FCUTEXT:8		CH 2 C

Volvo Truck Corporation

Document title  
WIRING DIAGRAM TYPE OLDocument type  
PRODUCT SCHEMATIC

Document No

24403869

Issue

01

Volume

2 (2)

Page

24 (63)

0

1

2

3

4

0

1

2

3

4

## REFERENCES

REF	DESCRIPTION	PAGE
FCUTEXT:9		CH 2 C
FCUTEXT:11		CA 2 C
FCUTEXT:12		CH 2 C
FCUTEXT:14		CA 2 C
FCUTEXT:15		CH 1 C
FCUTEXT:16		CH 1 C
FCUTEXT:17		CA 3 E
FCUTEXT:18		CA 3 E
FCUTEXT:21		CA 3 C
FCUTEXT:22		CA 3 C
FM1_A2		AD 1 B
FM3	FUSE MAIN PWR. CAB	AC 3 D
FM3_A1	MAIN CIRCUIT BREAKER	AC 4 D
FM5	RCIOM power supply 1	CG 2 C
FRC1:A1		CH 0 A
FRC1:A2		AB 2 C
FRC1:A4		BE 0 A
FRC1:A5		DD 3 A
FRC1:A6		BC 2 A
FRC1:A7		BA 2 A
FRC1:A8		BA 0 A
FRC1:A9		KA 1 A
FRC1:A9		NA 4 A
FRC1:A10		FC 1 A
FRC1:A11		GG 1 A
FRC1:A11		NA 0 A
FRC1:A12		NB 0 A
FRC1:A13		GP 0 A
FRC1:A14		GP 2 A
FRC1:A15		GP 4 A
FRC1:A16		FB 2 A
FRC1:B1		AB 3 C
FRC1:B2		AB 3 C
FRC1:B3		AA 0 B
FRC1:B4		AA 0 C
FRC1:C1		DD 0 A
FRC1:C2		KC 3 A
FRC1:C3		IF 0 A
FRC1:C4		CD 3 A
FRC1:C5		NB 0 A
FRC1:C6		CA 0 A
FRC1:C6		CJ 3 A
FRC1:C7		GD 3 A
FRC1:C8		GD 1 A
FRC1:C9		KA 3 A
FRC1:C9		XA 2 A
FRC1:C9		XB 2 A
FRC1:C10		KC 2 A
FRC1:C11		AC 0 A
FRC1:C12		GH 3 A

Volvo Truck Corporation

Document title  
WIRING DIAGRAM TYPE OLDocument type  
PRODUCT SCHEMATIC

Document No

24403869

Issue

01

Volume

2 (2)

Page

25 (63)

0

1

2

3

4

0

1

2

3

4

## REFERENCES

REF	DESCRIPTION	PAGE
FRC1:C13		GA 4 A
FRC1:C14		GA 2 A
FRC1:C15		GA 0 A
FRC1:C16		GA 1 A
FRC1:E1		NA 2 A
FRC1:E2		IC 0 A
FRC1:E2		ID 2 A
FRC1:E3		BE 0 A
FRC1:E4		FC 1 A
FRC1:E5		CD 2 A
FRC1:E6		EA 3 A
FRC1:E6		EE 2 B
FRC1:E7		NB 1 A
FRC1:E8		GG 1 A
FRC1:E8		NA 0 A
FRC1:E9		GD 0 A
FRC1:E10		GG 2 A
FRC1:E11		GQ 3 B
FRC1:E12		GA 2 A
FRC1:E13		NB 3 A
FRC1:E14		GG 3 A
FRC1:E15		NA 3 A
FRC1:E16		AA 4 B
FRC1:F1		AA 2 D
FRC1:F2		AA 2 C
FRC1:F3		AA 3 D
FRC1:F4		AA 3 C
FRC1:F8		CA 1 B
FRC1:G1		BB 2 A
FRC1:G2		EA 3 A
FRC1:G2		EE 2 B
FRC1:G3		NA 3 A
FRC1:G4		KC 1 A
FRC1:G5		CG 2 A
FRC1:G6		GG 1 A
FRC1:G7		CA 0 A
FRC1:G8		CA 1 B
FRC1:G9		IE 1 A
FRC1:G10		IE 0 A
FRC1:G11		IC 2 A
FRC1:G11		ID 1 A
FRC1:G12		HA 0 A
FRC1:G13		NB 2 A
FRC1:G14		FA 2 A
FRC1:G15		DD 4 A
FRC1:G16		NB 1 A
FRC1_P1	STUD, FRC1 POWER	AA 0 B
FRC1_P2	STUD, FRC1 POWER #2	AA 0 B
FRC1_P3	STUD, FRC1 POWER #3	AA 0 B
FRC2:A30		DD 2 B

Volvo Truck Corporation

Document title  
WIRING DIAGRAM TYPE OLDocument type  
PRODUCT SCHEMATIC

Document No

24403869

Issue

01

Volume

2 (2)

Page

26 (63)

0

1

2

3

4



0

1

2

3

4

## REFERENCES

REF	DESCRIPTION	PAGE
FRC2:A85		DD 2 B
FRC2:A86		DD 2 B
FRC2:A87		DD 2 B
FRC2:B30		GA 3 B
FRC2:B85		GA 3 B
FRC2:B86		GA 3 B
FRC2:B87		GA 3 B
FRC2:C30		GA 3 B
FRC2:C85		GA 3 B
FRC2:C86		GA 3 B
FRC2:C87		GA 3 B
FRC2:D30		FB 0 A
FRC2:D85		FB 0 A
FRC2:D86		FB 0 B
FRC2:D87A		FB 0 B
FRC2:E30		GG 3 B
FRC2:E85		GG 3 B
FRC2:E86		GG 3 B
FRC2:E87		GG 3 B
FRC2:F30		CA 0 B
FRC2:F85		CA 0 B
FRC2:F86		CA 0 B
FRC2:F87		CA 0 B
FRC2:G30		GA 2 C
FRC2:G85		GA 1 C
FRC2:G86		GA 1 C
FRC2:G87		GA 2 C
FRC2:J30		NB 3 B
FRC2:J85		NB 3 B
FRC2:J86		NB 3 B
FRC2:J87		NB 3 B
FRC2:K30		NB 3 B
FRC2:K85		NB 2 B
FRC2:K86		NB 2 B
FRC2:K87		NB 3 B
FRC2:L30		DD 3 B
FRC2:L85		DD 3 B
FRC2:L86		DD 3 B
FRC2:L87		DD 3 B
FRC2:M30		DD 4 B
FRC2:M85		DD 4 B
FRC2:M86		DD 4 A
FRC2:M87		DD 4 A
FRC2:M87A		DD 4 A
FRC2:N30		DD 2 B
FRC2:N85		DD 2 B
FRC2:N86		DD 2 B
FRC2:N87A		DD 2 B
FRC2:P30		DD 3 B
FRC2:P85		DD 3 B

Volvo Truck Corporation

Document title  
WIRING DIAGRAM TYPE OLDocument type  
PRODUCT SCHEMATIC

Document No

24403869

Issue

01

Volume

2 (2)

Page

27 (63)

0

1

2

3

4

0

1

2

3

4

## REFERENCES

REF	DESCRIPTION	PAGE
FRC2:P86		DD 3 B
FRC2:P87		DD 3 B
FRC2:R1		BB 3 B
FRC2:R3		BB 3 B
FRC2:R4		GH 0 B
FRC2:R6		GH 0 B
FRC2:R7		CD 1 A
FRC2:R8		CD 1 B
FRC2:S1		BB 3 B
FRC2:S2		BB 3 B
FRC2:S3		BB 3 B
FRC2:S4		GH 0 B
FRC2:S5		GH 0 B
FRC2:S6		GH 0 B
FRC2:S7		CD 0 A
FRC2:S7		CI 4 B
FRC2:S8		CD 0 B
FRC2:S8		CI 4 B
FRC2:T1		KA 3 B
FRC2:T2		KA 3 B
FRC2:T3		JG 2 A
FRC2:T4		JG 2 B
FRC2:T7		CJ 2 B
FRC2:T8		CJ 2 B
FRC3:A30		GD 0 C
FRC3:A85		GD 0 C
FRC3:A86		GD 0 B
FRC3:A87		GD 0 B
FRC3:A87A		GD 0 B
FRC3:B30		GD 1 C
FRC3:B85		GD 1 C
FRC3:B86		GD 1 B
FRC3:B87		GD 1 B
FRC3:B87A		GD 1 B
FRC3:C30		GA 1 A
FRC3:C85		GA 1 A
FRC3:C86		GA 1 B
FRC3:C87A		GA 1 B
FRC3:D30		KC 2 B
FRC3:D85		KC 2 B
FRC3:D86		KC 2 B
FRC3:D87		KC 2 B
FRC3:D87A		KC 2 B
FRC3:E30		AC 2 C
FRC3:E85		AC 1 C
FRC3:E86		AC 1 D
FRC3:E87		AC 2 D
FRC3:F30		AA 2 B
FRC3:F85		AA 1 B
FRC3:F86		AA 1 C

Volvo Truck Corporation

Document title  
WIRING DIAGRAM TYPE OLDocument type  
PRODUCT SCHEMATIC

Document No

24403869

Issue

01

Volume

2 (2)

Page

28 (63)

0

1

2

3

4

0

1

2

3

4

## REFERENCES

REF	DESCRIPTION	PAGE
FRC3:F87		AA 2 C
FRC3:G30		GG 2 B
FRC3:G85		GG 2 B
FRC3:G86		GG 2 B
FRC3:G87		GG 2 B
FRC3:H30		GP 2 B
FRC3:H85		GP 2 B
FRC3:H86		GP 2 C
FRC3:H87		GP 2 C
FRC3:H87A		GP 2 C
FRC3:J30		GP 2 B
FRC3:J85		GP 2 B
FRC3:J86		GP 2 C
FRC3:J87		GP 2 C
FRC3:J87A		GP 2 C
FRC3:K30		GP 3 B
FRC3:K85		GP 3 B
FRC3:K86		GP 3 C
FRC3:K87		GP 3 C
FRC3:K87A		GP 3 C
FRC3:L30		GP 4 B
FRC3:L85		GP 3 B
FRC3:L86		GP 3 C
FRC3:L87		GP 4 C
FRC3:L87A		GP 4 C
FRC3:M30		GQ 3 C
FRC3:M85		GQ 2 C
FRC3:M86		GQ 2 C
FRC3:M87		GQ 3 C
FRC3:N30		FC 1 B
FRC3:N85		FC 1 B
FRC3:N86		FC 1 B
FRC3:N87		FC 1 B
FRC3:P30		FC 2 B
FRC3:P85		FC 2 B
FRC3:P86		FC 2 B
FRC3:P87		FC 2 B
FRC3:R1		GA 4 C
FRC3:R3		GA 4 C
FRC3:R4		BB 4 C
FRC3:R6		BB 4 B
FRC3:R7		HA 1 B
FRC3:R8		HA 1 B
FRC3:S1		GA 4 C
FRC3:S2		GA 4 C
FRC3:S3		GA 4 C
FRC3:S4		BB 4 C
FRC3:S5		BB 4 C
FRC3:S6		BB 4 B
FRC3:S7		BW 1 B

Volvo Truck Corporation

Document title  
WIRING DIAGRAM TYPE OLDocument type  
PRODUCT SCHEMATIC

Document No

24403869

Issue

01

Volume

2 (2)

Page

29 (63)

0

1

2

3

4

0

1

2

3

4

## REFERENCES

REF	DESCRIPTION	PAGE
FRC3:S8		BW 1 B
FRC3:T1		CG 2 C
FRC3:T2		CG 2 C
FRC3:T3		JG 1 A
FRC3:T4		JG 1 B
FRC3:T5		NA 1 C
FRC3:T6		NA 1 D
FRC3:T7		GD 4 B
FRC3:T8		GD 4 C
G01	Battery	AB 0 D
G01	Battery	AC 3 C
G01	Battery	AD 2 B
G01	Battery	BN 0 B
G01	Battery	CH 0 B
G01	Battery	CJ 5 A
G01	Battery	KA 4 A
G01_A1:A		AC 3 C
G01_A3		AC 3 C
G01_A4:A		AC 3 C
G01_F:A		CJ 4 A
G02	Alternator	AC 4 B
G02	Alternator	AD 0 A
G02	Alternator	BP 0 A
G02_R	ALTERNATOR R TERMINAL	BP 0 B
H02	Horn	GQ 3 C
H02A	Horn	GQ 2 D
H02B	Horn	GQ 3 D
H02DHJ:A		GQ 3 D
H03	Reverse warner, acoustic	GF 3 B
H16	METHANE FUME DETECTOR	CI 1 B
H17	METHANE DETECTION STATUS	CI 3 B
HOOKUP_LP:A		NA 2 B
HOOKUP_LP:B		NA 2 B
ILLUM_OPT1:A		BE 4 D
ILLUM_OPT1:B		BE 4 D
ILLUM_OPT2:A		BE 4 D
ILLUM_OPT2:B		BE 4 D
ILLUM_OPT6:A		FD 1 A
ILLUM_OPT6:B		FD 1 C
ILLUM_OPT7:A		FD 1 A
ILLUM_OPT7:B		FD 1 C
ILLUM_OPT:A		NA 2 B
ILLUM_OPT:B		NA 2 B
IMS:A		AC 3 C
LHCS:A		CD 3 B
LHCS:B		BE 1 B
LHCS:C		CD 4 B
LHCS:D		CJ 2 D
LHCS:E		CD 3 C
LHCS:F		CD 3 B

Volvo Truck Corporation

Document title  
WIRING DIAGRAM TYPE OL

Document type  
PRODUCT SCHEMATIC

Document No

24403869

Issue

01

Volume

2 (2)

Page

30 (63)

0

1

2

3

4

0

1

2

3

4

## REFERENCES

REF	DESCRIPTION	PAGE
LHCS:G		CD 2 B
LHCS:H		CD 3 B
LHCS:J		BE 0 B
LHCS:K		CD 4 B
LHCS:L		CJ 2 D
LHCS:M		CD 2 C
LHCS:N		CJ 2 D
LHCS:P		CD 4 C
LHSP:A		CD 2 B
LHSP:B		CD 3 B
M01L	MOTOR WINDSHIELD WIPER LH	GP 3 C
M01R	MOTOR WINDSHIELD WIPER RH	GP 2 C
M02	MOTOR WS. WASHER PUMP	GP 0 C
M06DS	DRIVER driver MOTOR, Motor, P.WINDOW side	IE 0 D
M06PS	MOTOR, Motor, P.WINDOW PASSENGER passenge	IE 2 D
M58L	Motor, Door lock	IF 3 D
M58R	Motor, Door lock	IF 3 C
M78L	MOTOR MIRROR LEFT SIDE	IC 0 D
M78L	MOTOR MIRROR LEFT SIDE	ID 0 B
M78R	MOTOR MIRROR RIGHT SIDE	IC 3 C
M78R	MOTOR MIRROR RIGHT SIDE	ID 3 B
M120A	MOTOR, AUX. COOLING FAN #1	CD 0 E
M120B	MOTOR, AUX. COOLING FAN #2	CD 1 E
M121A	MOTOR AUX. COOLING FAN #1	CD 2 D
M121B	MOTOR AUX. COOLING FAN #2	CD 3 D
MCAF:A		CD 0 A
MCAF:B		CD 1 A
MCCOD:1		CI 0 D
MCCS:A		AC 1 B
MCDPL1:1		IF 2 D
MCDPL1:2		IF 4 D
MCDPL2:1		IE 0 C
MCDPL2:2		IE 0 D
MCDPL3:1		IC 0 D
MCDPL3:1		ID 0 C
MCDPL3:2		IC 1 D
MCDPL3:2		ID 0 C
MCDPL3:3		IC 0 D
MCDPL3:3		ID 0 C
MCDPL3:4		IC 0 D
MCDPL3:4		ID 0 C
MCDPL4:1		IC 0 D
MCDPL4:1		ID 0 C
MCDPL4:3		ID 0 C
MCDPL4:5		ID 0 C
MCDPL4:6		ID 0 C
MCDPR1:1		IF 2 C
MCDPR1:2		IF 4 C
MCDPR2:1		IE 1 C
MCDPR2:2		IE 2 D

Volvo Truck Corporation

Document title  
WIRING DIAGRAM TYPE OLDocument type  
PRODUCT SCHEMATIC

Document No

24403869

Issue

01

Volume

2 (2)

Page

31 (63)

0

1

2

3

4

0

1

2

3

4

## REFERENCES

REF	DESCRIPTION	PAGE
MCDPR3:1		IC 1 D
MCDPR3:1		IC 3 D
MCDPR3:1		ID 4 C
MCDPR3:2		IC 1 D
MCDPR3:2		IC 4 D
MCDPR3:2		ID 4 C
MCDPR3:3		IC 1 D
MCDPR3:3		IC 3 D
MCDPR3:3		ID 3 C
MCDPR3:4		IC 1 D
MCDPR3:4		IC 3 D
MCDPR3:4		ID 4 C
MCDPR4:1		IC 1 D
MCDPR4:1		IC 3 D
MCDPR4:1		ID 4 C
MCDPR4:3		IC 4 D
MCDPR4:3		ID 4 C
MCDPR4:5		IC 4 D
MCDPR4:5		ID 4 C
MCDPR4:6		IC 4 D
MCDPR4:6		ID 4 C
MCDSL:A		GH 3 E
MCDSL:B		GH 2 E
MCDSR:A		GH 3 E
MCDSR:B		GH 4 E
MCFC2:1		BX 3 B
MCFC2:2		EF 2 C
MCFC2:3		BX 1 C
MCFC2:4		BX 1 C
MCFC2:5		BX 3 C
MCFC2:7		BX 2 C
MCFC2:8		BX 1 B
MCFC2:9		EF 2 C
MCFC2:10		EF 0 B
MCFC2:11		EF 2 C
MCFC2:12		EF 1 B
MCFC2:13		EF 2 C
MCFC2:14		BX 1 C
MCFC2:15		EF 2 C
MCFC2:17		EF 3 B
MCFC2:19		EF 3 C
MCFC:5		BN 1 C
MCFC:6		BN 1 C
MCFC:7		CD 0 D
MCFC:8		CD 1 D
MCFC:9		DC 0 B
MCFC:10		DC 0 B
MCFC:11		DC 0 B
MCFC:12		DC 0 B
MCFC:13		DC 0 B

Volvo Truck Corporation

Document title  
WIRING DIAGRAM TYPE OLDocument type  
PRODUCT SCHEMATIC

Document No

24403869

Issue

01

Volume

2 (2)

Page

32 (63)

0

1

2

3

4

0

1

2

3

4

## REFERENCES

REF	DESCRIPTION	PAGE
MCFC:14		DC 0 B
MCFC:15		DC 2 C
MCFC:16		FB 0 C
MCFC:17		FB 0 D
MCFC:18		XC 1 B
MCFC:18		XC 4 A
MCFC:18		XE 2 B
MCFC:19		XC 2 B
MCFC:19		XC 4 A
MCFC:19		XE 2 C
MCFC:20		BD 2 D
MCFC:21		DC 0 B
MCFC:22		DC 0 B
MCFC:23		DC 1 B
MCFC:24		DC 1 B
MCFC:25		DC 1 B
MCFC:26		DC 1 B
MCFC:27		DC 2 C
MCFC:28		BE 3 B
MCFC:29		BE 3 B
MCFC:30		FB 1 C
MCFC:31		CG 2 D
MCFC:32		CG 1 C
MCFC:33		DC 1 B
MCFC:34		DC 1 B
MCFC:35		DC 1 B
MCFC:36		DC 1 B
MCFC:37		DC 1 B
MCFC:38		DC 1 B
MCFC:39		FD 1 C
MCFC:40		CD 3 A
MCFC:41		CJ 4 D
MCFC:42		CJ 4 D
MCFC:44		CJ 4 D
MCFC:45		DC 2 B
MCFC:46		DC 2 B
MCFC:47		DC 2 B
MCFC:48		DC 2 B
MCFC:49		DC 2 B
MCFC:50		DC 2 B
MCFC:51		FD 1 B
MCFC:52		BE 1 B
MCFC:53		BE 1 B
MCFC:57		DC 2 B
MCFC:58		BE 1 D
MCFC:59		BE 2 E
MCFC:60		HA 0 D
MCFC:61		CJ 4 D
MCFC:62		FB 2 C
MCFC:63		XA 3 D

Volvo Truck Corporation

Document title  
WIRING DIAGRAM TYPE OLDocument type  
PRODUCT SCHEMATIC

Document No

24403869

Issue

01

Volume

2 (2)

Page

33 (63)

0

1

2

3

4

0

1

2

3

4

## REFERENCES

REF	DESCRIPTION	PAGE
MCFC:63		XB 4 E
MCFC:64		XA 3 E
MCFC:64		XB 4 D
MCFC:65		EA 1 D
MCFC:65		EE 4 D
MCFC:66		EA 1 D
MCFC:66		EE 4 D
MCFC:67		EA 1 D
MCFC:67		EE 1 C
MCFC:68		EA 1 B
MCFC:68		EE 0 C
MCFC:69		EA 1 B
MCFC:69		EE 1 C
MCFC:70		EA 1 D
MCFC:70		EE 1 C
MCFC:71		EA 1 D
MCFC:71		EE 0 C
MCFC:72		EA 0 D
MCFC:72		EE 0 C
MCFC:73		EA 1 D
MCFC:73		EE 0 D
MCFC:74		EA 1 D
MCFC:74		EE 3 D
MCFC:75		EA 1 B
MCFC:75		EE 1 C
MCFC:76		EA 1 B
MCFC:76		EE 1 C
MCFC:77		EA 2 D
MCFC:77		EE 0 D
MCFC:78		EA 0 D
MCFC:78		EE 0 D
MCFC:79		EA 1 B
MCFC:79		EE 2 C
MCFC:80		EA 1 B
MCFC:80		EE 2 C
MCFC:81		EA 1 B
MCFC:81		EE 0 C
MCFC:82		EA 0 B
MCFC:82		EE 1 C
MCFC:83		EA 0 A
MCFC:83		EE 1 C
MCFC:84		EA 0 D
MCFC:84		EE 1 C
MCFC:85		EA 1 A
MCFC:85		EE 0 C
MCFC:86		EA 1 D
MCFC:86		EE 3 D
MCFC:87		EA 4 E
MCFC:87		EE 2 D
MCFC:88		EA 3 E

Volvo Truck Corporation

Document title  
WIRING DIAGRAM TYPE OLDocument type  
PRODUCT SCHEMATIC

Document No

24403869

Issue

01

Volume

2 (2)

Page

34 (63)

0

1

2

3

4



0

1

2

3

4

## REFERENCES

REF	DESCRIPTION	PAGE
MCFC:88		EE 2 D
MCFC:89		EA 2 D
MCFC:89		EE 2 D
MCFC:90		EA 2 D
MCFC:90		EE 2 D
MCFC:91		EA 3 D
MCFC:91		EE 2 D
MCFC:92		EA 3 D
MCFC:92		EE 3 D
MCFC:93		EA 2 D
MCFC:93		EE 1 D
MCFC:94		EA 2 D
MCFC:94		EE 1 D
MCFC:95		EA 3 D
MCFC:95		EE 2 D
MCFC:96		EA 3 D
MCFC:96		EE 2 D
MCFC:97		CA 1 B
MCFC:98		GA 0 D
MCFC:99		CH 0 B
MCFC:100		AC 2 D
MCFC:102		BB 1 D
MCFC:103		CJ 3 D
MCFC:104		CJ 3 D
MCFC:105		GF 2 B
MCFC:106		GF 1 B
MCFC:107		BE 0 D
MCFC:108		BE 0 D
MCFC:109		GA 3 D
MCFC:110		BE 1 D
MCFC:110		CJ 2 B
MCFC:111		CA 0 B
MCFC:114		FB 3 D
MCFC:115		CG 2 C
MCFC:116		CJ 3 B
MCFC:121		CD 2 B
MCFC:122		CD 3 B
MCFC:124		CA 0 B
MCFC:125		CC 1 B
MCFC:126		NB 3 C
MCFC:127		FA 2 B
MCFC:128		KA 4 C
MCFG:A		CG 1 B
MCFG:B		CG 1 B
MCFG:C		CG 1 B
MCFG:D		CG 1 A
MCHVAC1:1		HA 2 D
MCHVAC1:3		HA 2 D
MCHVAC1:5		HA 2 D
MCHVAC1:6		HA 2 D

Volvo Truck Corporation

Document title  
WIRING DIAGRAM TYPE OL

Document No

Issue

Volume

Page

Document type  
PRODUCT SCHEMATIC

24403869

01

2 (2)

35 (63)

0

1

2

3

4

0

1

2

3

4

## REFERENCES

REF	DESCRIPTION	PAGE
MCHVAC1:7		HA 2 D
MCHVAC1:8		HA 1 D
MCHVAC1:10		HA 1 D
MCHVAC2:1		HA 2 D
MCHVAC2:2		HA 2 D
MCHVAC2:3		HA 2 D
MCHVAC2:4		HA 2 D
MCHVAC2:5		HA 2 D
MCHVAC2:6		HA 3 D
MCHVAC2:7		HA 3 D
MCHVAC2:8		HA 3 D
MCHVAC2:9		HA 3 D
MCHVAC2:10		HA 3 D
MCHVAC2:11		HA 3 D
MCHVAC2:12		HA 3 D
MCHVAC3:A		HA 0 C
MCHVAC3:B		HA 0 D
MCHVAC3:C		HA 0 C
MCHVAC3:D		HA 0 D
MCHVAC:A		AB 4 C
MCHVAC:B		AB 4 D
MCMD:1		CI 4 C
MCMD:2		CI 2 D
MCMD:3		CI 1 B
MCMD:4		CI 1 B
MCMIR:A		IC 0 B
MCMIR:A		IC 0 B
MCMIR:A		ID 2 A
MCMIRMEM:A		ID 2 A
MCPM1:A		IC 0 C
MCPM1:A		ID 2 C
MCPM1:B		IC 0 C
MCPM1:B		ID 2 C
MCPM1:C		IC 0 C
MCPM1:C		ID 2 C
MCPM1:D		IC 1 C
MCPM1:D		ID 3 C
MCPM1:E		IC 1 C
MCPM1:E		ID 3 C
MCPM1:F		IC 1 C
MCPM1:F		ID 3 C
MCPM1:G		ID 2 C
MCPM1:H		ID 2 C
MCPM1:J		ID 2 C
MCPM1:K		ID 2 C
MCPM2:A		IC 2 C
MCPM2:A		ID 1 C
MCPM2:B		IC 2 D
MCPM2:B		ID 1 D
MCPM2:C		IC 1 C

Volvo Truck Corporation

Document title  
WIRING DIAGRAM TYPE OL

Document No

Issue

Volume

Page

Document type  
PRODUCT SCHEMATIC

24403869

01

2 (2)

36 (63)

0

1

2

3

4

0

1

2

3

4

## REFERENCES

REF	DESCRIPTION	PAGE
MCPM2:C		ID 3 C
MCPM2:D		ID 2 C
MCPM2:E		ID 4 E
MCPRF:3		JG 3 B
MCPRF:4		JG 3 C
MCPRF:5		JG 3 B
MCPRF:6		JG 3 C
MCPRF:9		JG 3 C
MCPRF:10		JG 3 C
MCPSC1:A		BE 0 C
MCPSC1:B		BE 0 C
MCPSC1:C		BE 0 C
MCPSC1:D		BE 0 C
MCPSC1:E		BE 1 C
MCPSC1:F		BE 1 C
MCPSC1:G		BE 1 C
MCPSC1:H		BE 1 C
MCPSC1:J		BE 1 C
MCPSC1:K		BE 1 C
MCPSC1:L		BE 1 C
MCPSC1:M		BE 2 C
MCPSC1:N		BE 2 C
MCPSC1:P		BE 2 C
MCPSC1:R		BE 2 C
MCPSC1:S		BE 2 C
MCPSC2:A		BE 2 D
MCPSC2:B		BE 2 D
MCPSC2:C		BE 0 D
MCPSC2:D		BE 2 C
MCPSC2:E		BE 2 C
MCPSC2:F		BE 2 C
MCPSC2:G		BE 2 D
MCPSC2:H		BE 2 D
MCPSC2:J		BE 2 D
MCPSC2:K		BE 2 D
MCPSC2:L		BE 2 D
MCPSC2:M		BE 3 D
MCPSC2:N		BE 2 C
MCPSC2:P		BE 1 C
MCPSC2:R		BE 0 D
MCPSC2:S		BE 0 D
MCPSC3:A		BE 3 D
MCPSC3:B		BE 3 D
MCPSC3:C		BE 0 D
MCPSC3:D		BE 1 D
MCPSC3:E		BE 1 D
MCPSC3:F		BE 1 D
MCPSC3:G		BE 1 D
MCPSC3:H		BE 1 D
MCPSC3:J		BE 1 D

Volvo Truck Corporation

Document title  
WIRING DIAGRAM TYPE OLDocument type  
PRODUCT SCHEMATIC

Document No

24403869

Issue

01

Volume

2 (2)

Page

37 (63)

0

1

2

3

4

0

1

2

3

4

## REFERENCES

REF	DESCRIPTION	PAGE
MCPSC3:K		BE 1 D
MCPSC3:L		BE 1 D
MCPSC3:M		BE 2 C
MCPSC3:N		BE 3 C
MCPSC3:P		BE 3 C
MCPSC3:R		GQ 2 B
MCPSC3:S		GQ 0 C
MCRC:A		KC 3 B
MCRC:B		KC 2 C
MCRC:C		KC 1 B
MCRC:D		KC 3 D
MCRC:E		KC 2 D
MCRC:F		KC 1 D
MCRF1:A		GH 4 C
MCRF1:B		GH 2 C
MCRF1:C		GH 3 C
MCRF1:D		GH 3 B
MCRF1:E		KA 2 D
MCRF1:F		KA 2 D
MCRF1:G		KA 2 D
MCRF1:H		KA 2 D
MCRF2:A		GA 0 D
MCRF2:B		GA 3 D
MCRF2:C		GD 2 D
MCRF2:D		GD 4 D
MCRF2:E		GD 4 D
MCRF3:A		KA 1 D
MCRF3:B		KA 1 D
MCRF3:C		KA 1 D
MCRFAC:1		GG 0 C
MCRFC:A		BY 2 B
MCRFC:B		BY 2 B
MCRFC:C		BY 2 C
MCRFC:D		BY 2 C
MCRFC:E		BY 0 D
MCRFC:F		BY 1 D
MCRFC:G		BY 2 D
MCRFC:H		BY 2 D
MCRFC:J		BY 2 D
MCRFC:K		BY 2 D
MCRP170A:2		BN 2 B
MCRP170A:3		BP 0 C
MCRP170A:5		BN 2 B
MCRP170A:6		BN 3 B
MCRP170A:7		BN 3 B
MCRP170A:13		BN 3 B
MCRP170A:14		BN 3 B
MCRRM:A		KA 4 C
MCS01:1		FB 0 B
MCS01:2		AC 0 B

Volvo Truck Corporation

Document title  
WIRING DIAGRAM TYPE OLDocument type  
PRODUCT SCHEMATIC

Document No

24403869

Issue

01

Volume

2 (2)

Page

38 (63)

0

1

2

3

4

0

1

2

3

4

## REFERENCES

REF	DESCRIPTION	PAGE
MCS01:3		AC 0 B
MCS01:7		AC 0 C
MCS01:8		AC 0 C
MCS01:9		BA 3 B
MCS01:10		BA 3 C
MCS01:11		BA 3 D
MCS01:12		BB 0 A
MCS01:13		BB 0 B
MCS01:14		BD 1 B
MCS01:15		BD 1 C
MCS01:16		DD 1 A
MCS01:17		DD 1 B
MCS01:18		DD 1 B
MCS01:19		DD 1 B
MCS01:20		EA 2 A
MCS01:20		EE 4 C
MCS01:21		EA 2 B
MCS01:21		EE 2 C
MCS01:22		FB 2 B
MCS01:23		FB 1 B
MCS01:24		FB 2 C
MCS01:25		FB 4 C
MCS01:26		FC 1 B
MCS01:27		FC 1 C
MCS01:28		GA 0 B
MCS01:29		GD 4 A
MCS01:30		GD 4 B
MCS01:31		GA 1 C
MCS01:32		GH 2 C
MCS01:33		GH 3 C
MCS01:34		GA 0 B
MCS01:35		GH 4 C
MCS01:36		GH 4 B
MCS01:37		ID 1 C
MCS01:38		GH 3 D
MCS01:39		GP 0 B
MCS01:40		GP 0 B
MCS01:41		GP 1 C
MCS01:42		GP 1 C
MCS01:43		ID 2 C
MCS01:44		ID 2 B
MCS01:45		IF 1 D
MCS01:46		IF 1 B
MCS01:47		IF 1 B
MCS02:1		GH 2 D
MCS02:2		GH 1 E
MCS02:3		GH 1 E
MCS02:4		GH 1 E
MCS02:5		GA 0 B
MCS02:6		GA 0 C

Volvo Truck Corporation

Document title  
WIRING DIAGRAM TYPE OLDocument type  
PRODUCT SCHEMATIC

Document No

24403869

Issue

01

Volume

2 (2)

Page

39 (63)

0

1

2

3

4

0

1

2

3

4

## REFERENCES

REF	DESCRIPTION	PAGE
MCS02:7		GA 0 C
MCS02:8		IC 2 B
MCS02:8		ID 1 B
MCS02:9		IC 2 C
MCS02:9		ID 1 B
MCS02:10		IE 0 B
MCS02:11		IE 0 C
MCS02:12		IE 0 C
MCS02:13		IE 1 B
MCS02:14		IE 2 A
MCS02:15		IE 2 C
MCS02:16		IE 2 C
MCS02:17		IC 1 C
MCS02:17		ID 3 B
MCS02:18		IC 0 C
MCS02:18		ID 2 B
MCS02:19		IC 1 C
MCS02:19		ID 3 B
MCS02:20		IC 0 C
MCS02:20		ID 2 B
MCS02:21		IC 0 C
MCS02:21		ID 2 B
MCS02:22		IC 0 B
MCS02:22		ID 2 A
MCS02:23		FB 0 C
MCS02:24		FB 1 C
MCS02:25		IC 1 C
MCS02:25		ID 3 B
MCS02:27		IC 1 C
MCS02:27		ID 3 B
MCS02:29		BD 1 C
MCSSC1:A		BG 0 B
MCSSC1:B		BG 0 B
MCSSC1:C		BG 0 B
MCSSC1:D		BG 0 B
MCSSC1:E		BG 0 B
MCSSC1:F		BG 0 B
MCSSC1:G		BG 1 B
MCSSC1:H		BG 1 B
MCSSC1:J		BG 1 B
MCSSC1:K		BG 1 B
MCSSC1:L		BG 1 B
MCSSC1:M		BG 2 B
MCSSC1:N		BG 2 B
MCSSC1:P		BG 2 B
MCSSC1:R		BG 2 B
MCSSC1:S		BG 2 B
MCSSC2:A		BG 2 D
MCSSC2:B		BG 2 D
MCSSC2:C		BG 0 D

Volvo Truck Corporation

Document title  
WIRING DIAGRAM TYPE OL

Document No

Issue

Volume

Page

Document type  
PRODUCT SCHEMATIC

24403869

01

2 (2)

40 (63)

0

1

2

3

4

0

1

2

3

4

## REFERENCES

REF	DESCRIPTION	PAGE
MCSSC2:D		BG 2 B
MCSSC2:E		BG 2 B
MCSSC2:F		BG 2 B
MCSSC2:G		BG 2 D
MCSSC2:H		BG 2 D
MCSSC2:J		BG 2 D
MCSSC2:K		BG 2 D
MCSSC2:L		BG 2 D
MCSSC2:M		BG 2 D
MCSSC2:N		BG 2 B
MCSSC2:P		BG 1 B
MCSSC2:R		BG 3 B
MCSSC2:S		BG 3 B
MCTL:A		GF 2 C
MCTL:B		GF 1 C
MCTL:C		GF 1 C
MCTL:D		GF 2 C
MCTL:E		GF 2 D
MCWB1:A		GP 0 C
MCWB1:B		GP 0 C
MCWB2:A		BE 3 B
MCWB2:B		BE 3 A
MSTC-2_3447	GXL_0.8_2	CA 3 B
MSTC-3_3447	GXL_0.8_2	CA 3 E
PMCPR:1		BX 1 C
PMCPR:2		BX 1 C
PMCPR:5		BX 0 B
PMCPR:6		BX 0 B
PMCPR:7		BX 1 D
PMCPR:8		BX 1 E
PPCO:A		FD 1 B
PPCO:B		FD 1 B
PPCO:C		FD 0 C
PRCFC:1		BX 3 C
PRCFC:2		BX 2 D
PRCFC:3		BX 3 C
PRCFC:4		BX 3 C
PRCFC:5		BX 3 B
PRCFC:6		BX 3 B
PRCFC:7		BX 4 D
PSCTS:A		GA 2 B
PSCTS:A		GA 2 B
PSCTS:B		GA 2 B
PSCTS:C		GA 2 B
PSCTS:D		GA 2 B
PSCTS:D		GA 3 B
PSCTS:E		GA 3 C
PSCTS:F		GA 2 D
PSCTS:G		GA 3 D
PSCTS:G		GA 3 D

Volvo Truck Corporation

Document title  
WIRING DIAGRAM TYPE OLDocument type  
PRODUCT SCHEMATIC

Document No

24403869

Issue

01

Volume

2 (2)

Page

41 (63)

0

1

2

3

4

0

1

2

3

4

## REFERENCES

REF	DESCRIPTION	PAGE
PSCTS:H		GA 3 D
PSCTS:H		GA 3 C
PSCTS:J		EF 1 D
PSCTS:K		EF 1 D
PSCTS:L		EF 1 D
PSCTS:M		EF 1 D
R01	HEATER, ENGINE PREHEAT	AD 0 A
R04	CIGAR LIGHTER	KC 3 C
R05	Heater, air dryer	FA 3 C
R05A	AIR DRYER, HEATED	FA 2 C
R05B	AIR DRYER, HEATED	FA 0 C
R08	RESISTOR, TERMINATION J1939 CAN	XA 3 A
R08	RESISTOR, TERMINATION J1939 CAN	XB 4 A
R08B	TERM RESISTOR	BY 2 B
R08D	Terminating Resistor	BX 0 C
R08E	Terminating Resistor	BX 4 C
R09	HEATER, FUEL WATER SEPARATOR	CC 1 C
R14	Termination resistor	XC 2 C
R14B	Termination resistor	XC 2 B
R19A	HEATER HEATED DRAIN VALVE COOLING TANK	FA 0 C
R19B	HEATER HEATED DRAIN VALVE WET TANK	FA 1 C
R21A	TERM RESISTOR	XE 2 B
R21B	TERM RESISTOR	XE 1 B
R29	Heater, NOxCare tank to pump hose	CH 3 E
R31	Heater, NOxCare pump to injector hose	CH 3 D
R34	Termination resistor	XB 1 E
R39A	RESISTOR, CUMMINS PULL UP IVS	BC 2 C
R39B	RESISTOR CUMMINS PULL DOWN FUEL LEVEL	BE 1 D
R78	HEATER ENGINE BLOCK COOLANT	CC 2 C
RC1:A1		BA 1 B
RC1:A3		BA 1 B
RC1:A4		GA 3 D
RC1:A6		GA 2 D
RC1:A7		DE 2 B
RC1:A9		DE 2 B
RC1:B1		BA 1 B
RC1:B2		BA 1 B
RC1:B3		BA 1 B
RC1:B4		GA 3 D
RC1:B5		GA 2 D
RC1:B6		GA 3 D
RC1:B7		DE 2 B
RC1:B8		DE 2 B
RC1:B9		DE 2 B
RC1:C1		GH 0 B
RC1:C2		GH 1 B
RC1:C3		GH 0 B
RC1:C4		GH 1 B
RC1:C5		GH 1 B
RC1:C6		GH 1 B

Volvo Truck Corporation

Document title  
WIRING DIAGRAM TYPE OL

Document No

Issue

Volume

Page

Document type  
PRODUCT SCHEMATIC

24403869

01

2 (2)

42 (63)

0

1

2

3

4



0

1

2

3

4

## REFERENCES

REF	DESCRIPTION	PAGE
RC1:C7		BB 1 B
RC1:C9		BB 1 A
RC1:D1		GH 0 B
RC1:D3		GH 0 B
RC1:D4		GH 1 B
RC1:D6		GH 1 B
RC1:D7		BB 1 B
RC1:D9		BB 1 A
RC2:A1		GD 0 A
RC2:A3		GD 0 B
RC2:A4		GD 1 B
RC2:A6		GD 2 B
RC2:A7		NA 0 C
RC2:A9		NA 0 D
RC2:B1		GD 0 A
RC2:B2		GD 0 B
RC2:B3		GD 0 B
RC2:B4		GD 2 B
RC2:B5		GD 1 B
RC2:B6		GD 1 B
RC2:B7		NA 0 C
RC2:B8		NA 0 D
RC2:B9		NA 0 D
RC2:C2		DE 1 C
RC2:C3		DE 1 B
RC2:C4		DE 0 C
RC2:C5		DE 0 C
RC2:C6		DE 0 B
RC2:C7		GA 1 D
RC2:C9		GA 1 C
RC2:D1		DE 1 C
RC2:D3		DE 1 B
RC2:D4		DE 0 C
RC2:D6		DE 0 B
RC2:D7		GA 1 D
RC2:D9		GA 1 C
RC6:A1		HA 0 C
RC6:A3		HA 0 C
RC6:B1		HA 0 C
RC6:B3		HA 0 C
RC6:C1		GD 3 C
RC6:C3		GD 3 B
RC6:C4		CD 0 C
RC6:C5		CI 0 C
RC6:C6		CD 0 C
RC6:C6		CI 0 C
RC6:C7		CD 1 C
RC6:C7		CI 0 B
RC6:C9		CD 1 C
RC6:C9		CI 0 A

Volvo Truck Corporation

Document title  
WIRING DIAGRAM TYPE OLDocument type  
PRODUCT SCHEMATIC

Document No

24403869

Issue

01

Volume

2 (2)

Page

43 (63)

0

1

2

3

4

## REFERENCES

REF	DESCRIPTION	PAGE
RC6:D1		GD 3 C
RC6:D3		GD 3 B
RC6:D4		CD 0 C
RC6:D4		CI 0 C
RC6:D6		CD 0 C
RC6:D6		CI 0 C
RC6:D7		CD 1 C
RC6:D7		CI 0 B
RC6:D9		CD 1 C
RC6:D9		CI 0 A
RCOLAY:1		BY 2 D
RCOLAY:2		BY 2 D
RCOLAY:3		BY 2 D
RCOLAY:4		BY 2 D
RCOLAY:5		BY 1 C
RCOLAY:6		BY 0 C
RFHL:A		GH 4 B
RFHL:B		GH 2 B
RFHL:C		GH 3 B
RFHL:D		GH 3 B
RFHL:E		KA 2 D
RFHL:F		KA 2 D
RFHL:G		KA 2 D
RFHL:H		KA 2 D
RFMIC:A		KA 2 C
RFMIC:B		KA 2 C
RLY01	RELAY EMS #1	AB 3 C
RLY02	RELAY EMS #2	AA 2 C
RLY03	RELAY IGN. #1	AA 0 B
RLY04	RELAY IGN. #3	AA 3 C
RLY05	RELAY HIGH BEAM	GA 1 C
RLY06	RELAY, EMERGENCY STOP LAMP	GA 3 B
RLY10	RELAY, LEFT/RIGHT SW. PWR.	BA 1 B
RLY11	RELAY TRAILER TAIL LAMP	GG 2 B
RLY12	RELAY TRAILER STOP LAMP	GG 3 B
RLY13	RELAY, CAB AND TRAILER CLEARANCE LAMP	GA 1 C
RLY14	RELAY, HORN	GQ 2 C
RLY15	RELAY HAZARD BYPASS	GA 4 C
RLY016A	RELAY WINDSHIELD WIPER RH LOW	GP 2 B
RLY016B	RELAY WINDSHIELD WIPER RH HIGH	GP 2 B
RLY016C	RELAY WINDSHIELD WIPER LH LOW	GP 3 B
RLY016D	RELAY WINDSHIELD WIPER LH HIGH	GP 3 B
RLY17	RELAY REVERSE POWER	DD 3 B
RLY19	El. adjustable seat (optional fan and hea	GD 3 B
RLY28	RELAY, CB BINDING POST	KC 2 B
RLY29	RELAY, NEUTRAL POWER	NB 2 B
RLY34	RELAY, PRE-EMS	AA 1 B
RLY35	RELAY, HVAC CAB	HA 0 B
RLY35:30		HA 0 B
RLY35:85		HA 0 B

Volvo Truck Corporation

Document title  
WIRING DIAGRAM TYPE OLDocument type  
PRODUCT SCHEMATIC

Document No

24403869

Issue

01

Volume

2 (2)

Page

44 (63)

## REFERENCES

REF	DESCRIPTION	PAGE
RLY35:86		HA 0 B
RLY35:87		HA 0 B
RLY36	RELAY START CNTL. 1	AC 1 C
RLY38	RELAY, LOW BEAM LEFT	GD 0 B
RLY39	RELAY, LOW BEAM RIGHT	GD 1 B
RLY45	RELAY PTO ENABLE	DD 4 B
RLY46	RELAY RANGE PTO	DD 3 B
RLY47	RELAY RETARDER	DD 2 B
RLY48	RELAY STOP LAMPS	DD 2 B
RLY49	RELAY AC CLUTCH	HA 0 C
RLY52	RELAY, HIGH BEAM	GA 1 B
RLY54	RELAY METHANE DETECTOR	CI 0 B
RLY58	RELAY BEACON LAMP PTO	FC 1 B
RLY59	RELAY BEACON LPS REVERSE	FC 2 B
RLY60	RELAY, PARK BRAKE STOP LAMP	GA 3 B
RLY61	RELAY LIFT AXLE REVERSE	FB 0 A
RLY62	RELAY, REVERSE BODY POWER	NB 3 B
RLY63	RELAY, POWER INDICATOR	GA 3 D
RLY63_JMP	JUMPER, CLEARANCE LIGHTS	GA 2 E
RLY64	1 DETECT METHANE RELAY RELAY, SPARE	NA 0 C
RLY68	RELAY, ENGINE COMP#1	CA 0 B
RLY70	RELAY, TPS L-R REF.	BB 4 C
RLY71	RELAY, TPS L-R IVS	BB 3 B
RLY72	RELAY DIRECTIONAL LAMPS L-R	GH 0 B
RLY73	RELAY LEFT COMB. STOP TURN LAMPS	GH 0 B
RLY74	RELAY HIGH BEAM SW. L-R	GH 1 B
RLY75	RELAY, ALLISON L-R SHIFT INHIBIT	BB 1 B
RLY76	RELAY ALLISON L/R SERVICE BRAKE INHIBIT	DE 2 B
RLY77	RELAY AUTO NEUTRAL PACKER	DE 0 C
RLY78	RELAY AUTO NEUTRAL WORK BRAKE	DE 1 C
RLY80	RELAY, WORK LAMPS LEFT	GD 0 A
RLY81	RELAY, WORK LAMPS RIGHT	GD 2 B
RLY89	RELAY, HEATER HIGH FAN SPEED	HA 1 C
RLY89:30		HA 1 C
RLY89:85		HA 1 C
RLY89:86		HA 1 C
RLY89:87		HA 1 C
RLY91	#1 (optional AUX. El. FAN RELAY adjustabl	CD 0 C
RLY92	#2 (optional AUX. El. FAN RELAY adjustabl	CD 1 C
RLY95	(optional 2 El. INTERRUPT RELAY START adj	BP 1 B
RLY96	RELAY RIGHT COMB. STOP TURN LAMPS	GH 1 B
RLY99	RELAY, METHANE DETECTION	CI 0 C
RLY113	RELAY, L/R MPH/RPM BRAKE STATUS CONTROLLE	DE 4 B
S01A	SWITCH, MAIN LIGHTING	GA 0 B
S03	Switch, loading lamps / working lamps	GD 4 A
S05A	Switch, interior light, selector type	GH 4 D
S05B	Switch, interior light, selector type	GH 2 D
S05C	Switch, interior light, selector type	GH 3 D
S07	Switch, engine brake, selector type	BA 3 C
S08	Switch, differential gear lock, rear whe	BD 1 B

Volvo Truck Corporation

Document title  
WIRING DIAGRAM TYPE OLDocument type  
PRODUCT SCHEMATIC

Document No

24403869

Issue

01

Volume

2 (2)

Page

45 (63)

## REFERENCES

REF	DESCRIPTION	PAGE
S09A	Switch, differential lock, rear inter-axl	FB 4 B
S13L	SWITCH, DIRECTIONAL SIGNAL LEFT	GA 2 C
S13R	SWITCH, DIRECTIONAL SIGNAL RIGHT	GH 0 D
S14L	SWITCH, HORN LEFT SIDE	GQ 0 C
S14R	SWITCH, HORN RIGHT SIDE	GQ 1 C
S019A	SWITCH, POWER DIVIDER LOCKOUT	FB 3 B
S28A	Switch, power take off 1	FD 0 B
S28D	Switch, power take off 4	FC 1 B
S30	Switch unit, multi-function display	BE 1 B
S30A	SWITCH 1 LEFT IC DISPLAY	BE 2 A
S30B	SWITCH RIGHT ICDISPLAY	BG 1 A
S30C	SWITCH 1 RIGHT IC DISPLAY	BG 2 A
S31	Switch, TCS ( Traction Control System )	EA 2 A
S31	Switch, TCS ( Traction Control System )	EE 3 B
S40	Switch, rear view camera, camera selecti	KA 0 B
S43	Pressure switch, parking brake indicator	BA 2 E
S43D	SW. PRESS PARK BRAKE BODYBUILDER	BP 1 B
S44	Position switch, door, interior light, N	GH 4 E
S44L	SWITCH DOOR LEFT	GH 3 E
S48P	SWITCH PRESSURE SERVICE BRAKE PRIMARY	GA 4 B
S48PL	SWITCH SERVICE BRAKE PRIMARY N/O LEFT	DE 3 C
S48PR	SWITCH SERVICE BRAKE PRIMARY N/O RIGHT	DE 2 C
S48S	SWITCH PRESSURE SERVICE BRAKE SECONDARY	GA 4 B
S48SL	SWITCH SERVICE BRAKE SECONDARY N/O LEFT	DE 4 C
S48SR	SWITCH SERVICE BRAKE SECONDARY N/O RIGHT	DE 3 C
S54	Position switch, differential gear lock,	BE 4 B
S71	Pressure switch, compressor charging, NO	HA 0 C
S103	Switch, heated mirror, mirror adjustment	IC 0 B
S103	Switch, heated mirror, mirror adjustment	ID 2 B
S105	Switch, Hazard warning light	GH 2 D
S106PS	SWITCH, PASSENGER POWER WINDOW	IE 2 B
S107	SWITCH, DRIVER POWER WINDOW	IE 0 B
S115	Switch, Door lock	IF 1 C
S117	Position switch, differential lock, rear	BE 4 B
S123	Switch, Mirror defrost	IC 2 B
S123	Switch, Mirror defrost	ID 1 B
S130	Switch, Air suspension	FB 2 B
S146	Switch, R/+ and S/-	BA 0 C
S146B	SWITCH RIGHT R+/S-	BA 1 C
S147A	Switch, RPM regulation	BA 2 C
S147B	Switch, RPM regulation	BA 3 C
S169	Switch, Battery Main Switch	AC 3 D
S190	Switch, pressure sensor / airconditioning	HA 0 D
S217	Switch, ignition, selector type (dashboar	AC 0 C
S218	Stalk switch, windscreen wiper, selector	GP 0 B
S314	SWITCH, RETARDER	DD 1 B
S330	SWITCH, BODY BUILDER PARK BRAKE	BB 0 E
S330	SWITCH, BODY BUILDER PARK BRAKE	BQ 0 C
S330JMP	SWITCH, BODY BUILDER PARK BRAKE JUMPER	BB 1 E
S330JMP	SWITCH, BODY BUILDER PARK BRAKE JUMPER	BQ 2 C

Volvo Truck Corporation

Document title  
WIRING DIAGRAM TYPE OLDocument type  
PRODUCT SCHEMATIC

Document No

24403869

Issue

01

Volume

2 (2)

Page

46 (63)

## REFERENCES

REF	DESCRIPTION	PAGE
S331	SWITCH, PARKER PTO ENGAGED	FD 1 C
S332	SWITCH, DIMMER	GA 1 B
S339	SWITCH, MASTER LEFT/RIGHT DRIVE	BB 0 A
S340	SWITCH, WORK BRAKE PRIMARY 1	DE 1 C
S340A	SWITCH, WORK BRAKE PRIMARY 2	DE 0 B
S340B	SWITCH WORK BRAKE SECONDARY 1	DE 1 B
S340C	SWITCH, WORK BRAKE SECONDARY 2	DE 0 B
S341A	SWITCH TAG AXLE LIFT	FB 0 C
S341B	SWITCH PUSHER AXLE LIFT	FB 0 B
S344	SWITCH PRESSURE PRIMARY LOW AIR	BF 1 C
S344A	SWITCH PRESSURE SECONDARY LOW AIR	BF 2 C
S347	SWITCH MIRROR MEMORY	ID 2 B
S493L	SWITCH BRAKE AUTO NEUTRAL LEFT	DD 0 B
S493R	SWITCH BRAKE AUTO NEUTRAL RIGHT	DD 0 B
S564F	JUMPER FRONT	BX 1 E
S564F	JUMPER FRONT	JG 2 B
S564G	JUMPER FRONT	BX 2 A
SC-4_560	MKFK_0.35_1	KA 2 C
SP_BAT1:A		NA 3 B
SP_FUSE:A		NA 1 C
SP_FUSE:B		NA 1 D
SP_IGN1:A		NA 3 B
SP_IGN1:B		NA 3 B
SP_IGN2:A		NA 4 B
SP_RLY:A		NA 0 C
SP_RLY:B		NA 0 D
SP_RLY:C		NA 0 D
SP_RLY:D		NA 0 D
SP_RLY:E		NA 0 C
SPAD1A1		EF 2 B
SPAD4A1		EF 3 B
SPAD7A1		EF 1 C
SPAD8A1		EF 1 C
SPAD10A1		EF 1 C
SPAD11A1		EF 1 C
SPCA11	T	BE 3 C
SPCA11	T	BG 3 B
SPCA11	T	GD 2 B
SPCA15	T	BE 1 B
SPCB1	T	BA 1 E
SPCB10	T	BB 3 D
SPCB11	T	BA 2 E
SPCB13A	T	BB 2 B
SPCB13A5	T	BB 3 B
SPCB13A11	T	BB 2 B
SPCB16	T	CD 1 C
SPCB19	T	BB 2 D
SPCB19D	S	DE 3 B
SPCB19E	S	DE 2 B
SPCB19F	T	DE 3 D

Volvo Truck Corporation

Document title  
WIRING DIAGRAM TYPE OLDocument type  
PRODUCT SCHEMATIC

Document No

24403869

Issue

01

Volume

2 (2)

Page

47 (63)

0

1

2

3

4

## REFERENCES

REF	DESCRIPTION	PAGE
SPCB19G	T	BQ 3 C
SPCB22	T	BB 2 D
SPDL1H	S	XA 3 E
SPDL1H1	S	XA 3 D
SPDL1H1	S	XB 4 D
SPDL1H2	S	XA 3 D
SPDL1H2	S	XB 4 D
SPDL1H3	S	XA 3 B
SPDL1H3	S	XB 4 C
SPDL1H4	S	XA 3 B
SPDL1H4	S	XB 4 B
SPDL1H5	S	XA 3 B
SPDL1H5	S	XB 4 B
SPDL1H6	S	XA 3 B
SPDL1H6	S	XB 4 B
SPDL1H7	S	XA 3 C
SPDL1H7	S	XB 4 C
SPDL1H8	S	XB 4 A
SPDL1H9		XA 3 D
SPDL1H12		XA 3 D
SPDL1H15		JG 2 B
SPDL1H16		JG 2 C
SPDL1H17		JG 2 C
SPDL1HN10	S	XB 3 E
SPDL1HN12	S	XB 3 E
SPDL1HN14	S	XB 2 E
SPDL1L	S	XA 3 E
SPDL1L1	S	XA 3 D
SPDL1L1	S	XB 4 D
SPDL1L2	S	XA 3 C
SPDL1L2	S	XB 4 D
SPDL1L3	S	XA 3 C
SPDL1L3	S	XB 4 C
SPDL1L4	S	XA 3 B
SPDL1L4	S	XB 4 B
SPDL1L5	S	XA 3 B
SPDL1L5	S	XB 4 B
SPDL1L6	S	XA 3 B
SPDL1L6	S	XB 4 B
SPDL1L7	S	XA 3 C
SPDL1L7	S	XB 4 C
SPDL1L8	S	XB 4 B
SPDL1L9		XA 3 D
SPDL1L12		XA 3 D
SPDL1L15		JG 2 B
SPDL1L16		JG 3 B
SPDL1L17		JG 3 C
SPDL1LN10	S	XB 3 E
SPDL1LN12	S	XB 3 E
SPDL1LN14	S	XB 2 E

Volvo Truck Corporation

Document title  
WIRING DIAGRAM TYPE OLDocument type  
PRODUCT SCHEMATIC

Document No

24403869

Issue

01

Volume

2 (2)

Page

48 (63)

0

1

2

3

4

0

1

2

3

4

## REFERENCES

REF	DESCRIPTION	PAGE
SPDL2H1	S	CH 2 B
SPDL2H2	S	XC 1 B
SPDL2H3	S	XC 1 C
SPDL2H4	S	XC 1 C
SPDL2H5	S	XC 1 D
SPDL2H6	S	XC 4 C
SPDL2H7		XC 1 B
SPDL2L1	S	CH 2 B
SPDL2L2	S	XC 2 B
SPDL2L3	S	XC 2 C
SPDL2L4	S	XC 2 C
SPDL2L5	S	XC 2 D
SPDL2L6	S	XC 4 C
SPDL2L7		XC 2 B
SPDL4H	S	BY 2 C
SPDL4H	S	XD 2 B
SPDL4L	S	BY 2 C
SPDL4L	S	XD 2 B
SPDL5H101		BY 2 C
SPDL5H102		BY 2 B
SPDL5HB1		BB 1 C
SPDL5L101		BY 2 C
SPDL5L102		BY 2 B
SPDL5LB1		BB 1 C
SPDL7H1	S	CA 3 C
SPDL7L1	S	CA 3 C
SPDL10H1	S	XE 2 B
SPDL10H2	S	XE 1 B
SPDL10L1	S	XE 3 C
SPDL10L2	S	XE 1 C
SPECHA1	S	CJ 2 D
SPECKA1	S	CJ 2 D
SPEMA28A1	S	CH 3 C
SPEMA49A	S	CA 2 C
SPEMA54A1	S	CH 1 C
SPEMA59A1	S	CH 3 D
SPEMA62A	S	CH 2 D
SPF2B	T	GA 1 B
SPF2C	T	GA 0 C
SPF2G	T	GD 2 C
SPF2H	T	GD 2 C
SPF3B	T	GA 0 C
SPF3B7	S	GF 1 B
SPF3B8		GF 1 C
SPF3B20	S	GA 0 C
SPF3C	T	GA 0 D
SPF3D	T	GD 3 A
SPF3F	T	BE 1 A
SPF3F	T	BG 1 A
SPF3F	T	CG 1 A

Volvo Truck Corporation

Document title  
WIRING DIAGRAM TYPE OLDocument type  
PRODUCT SCHEMATIC

Document No

24403869

Issue

01

Volume

2 (2)

Page

49 (63)

0

1

2

3

4

REFERENCES

REF	DESCRIPTION	PAGE
SPF3F	T	DE 0 D
SPF3F	T	GH 4 A
SPF3F	T	KA 3 B
SPF3F	T	NA 2 A
SPF3F1	T	BA 2 B
SPF3F69	T	FD 0 A
SPF3F74	T	BE 4 D
SPF3F100	S	DD 2 B
SPF3F100	S	FB 1 B
SPF3F100	S	FC 0 B
SPF3F100	S	GD 4 A
SPF3F100	S	GH 3 C
SPF3F100	S	ID 2 A
SPF3F100	S	IE 2 B
SPF3F100	S	IF 1 C
SPF3F110	T	BE 1 A
SPF3F110	T	DD 0 B
SPF3F116	T	BG 1 A
SPF3F200	S	BA 3 B
SPF3F200	S	BD 2 B
SPF3F200	S	EA 3 A
SPF3F200	S	EE 3 A
SPF3F200	S	GA 1 B
SPF3F200	S	GH 3 C
SPF3F200	S	GP 0 B
SPF3F200	S	IC 2 B
SPF3F200	S	ID 1 A
SPF3F200	S	IE 0 B
SPF3G	T	GA 0 A
SPF3H	T	GA 2 B
SPF3J	T	GA 0 C
SPF3K	T	GA 0 D
SPF3M	S	GD 4 B
SPF4B	T	GA 2 B
SPF4B3	S	GH 2 D
SPF4B3C	S	GH 2 E
SPF4C	T	GD 3 C
SPF4D	T	GD 4 C
SPF4E	T	GD 4 C
SPF4EA5		JG 3 C
SPF4F	T	GD 2 C
SPF4FA5		JG 3 C
SPF4G	T	GD 3 D
SPF4H	T	GD 3 C
SPF5A	T	GA 4 B
SPF5A1	S	GA 4 B
SPF5B	T	GA 4 C
SPF5B1	S	GA 4 C
SPF5B5	T	GA 4 C
SPF5D1	S	GF 2 B

Volvo Truck Corporation

Document title  
WIRING DIAGRAM TYPE OL

Document type  
PRODUCT SCHEMATIC

Document No

24403869

Issue

01

Volume

2 (2)

Page

50 (63)



0

1

2

3

4

## REFERENCES

REF	DESCRIPTION	PAGE
SPF5E1	S	GF 1 B
SPF6A	T	GH 3 B
SPF6D	T	GH 4 B
SPF6E	S	GH 3 D
SPF6E3	T	GH 3 E
SPF7A	T	AC 0 B
SPF7C	T	AC 1 B
SPF7D	T	AC 1 C
SPF7D	T	XB 1 C
SPF7D8A2	S	CD 3 B
SPF7D10	T	CI 0 C
SPF7G	T	BF 2 B
SPF8A	T	FB 2 B
SPF8A2	S	FB 3 B
SPF8B	T	FB 4 D
SPF9B	T	KC 2 B
SPF9D	T	GA 2 D
SPF9D2	S	GA 3 D
SPF10A	T	KA 3 B
SPF10A	T	XA 2 B
SPF10A	T	XB 2 B
SPF10C	T	KA 3 C
SPF11A	T	BY 1 B
SPF11A	T	GG 1 B
SPF15A	T	FC 1 B
SPF15B	T	FC 2 C
SPF16A	T	BA 0 B
SPF17A	T	BA 2 B
SPF17C	T	BA 1 D
SPF17D	T	BA 1 C
SPF17E	T	BA 2 C
SPF18A	T	BC 2 B
SPF19	T	BE 0 B
SPF19	T	BG 0 B
SPF20A	T	IC 0 A
SPF20A	T	ID 2 A
SPF21A	T	GP 4 B
SPF22A	T	GP 2 B
SPF23A	T	GP 0 B
SPF23C	T	GP 2 A
SPF23D	T	GP 2 B
SPF25A	T	HA 0 A
SPF25B	T	HA 1 B
SPF27A	T	GG 1 B
SPF27A4	T	CG 1 C
SPF29B	T	AA 2 C
SPF30B	T	FC 1 C
SPF31A	T	DD 3 A
SPF31A9	T	DD 0 A
SPF31B	T	DE 0 B

Volvo Truck Corporation

Document title  
WIRING DIAGRAM TYPE OLDocument type  
PRODUCT SCHEMATIC

Document No

24403869

Issue

01

Volume

2 (2)

Page

51 (63)

0

1

2

3

4

0

1

2

3

4

## REFERENCES

REF	DESCRIPTION	PAGE
SPF31C	T	DD 2 B
SPF33B	T	GG 3 C
SPF34A	T	NB 3 B
SPF34B	T	NB 3 C
SPF34B1	S	GF 2 B
SPF34B10		GF 2 C
SPF35B	T	GA 2 C
SPF35C	S	GA 3 D
SPF35C1	S	GA 4 D
SPF35C3	S	GA 3 D
SPF36D	S	GQ 1 B
SPF36D1	T	GQ 1 C
SPF37B	T	GG 2 B
SPF38A	T	CA 0 B
SPF38A4	S	CA 0 C
SPF39A	T	GG 1 B
SPF41A	T	CG 2 C
SPF42B	T	DD 4 C
SPF43A	S	CA 1 C
SPF44A	S	FA 2 B
SPF45A	T	NB 2 D
SPF47A	T	NA 3 B
SPF52A	T	HA 0 B
SPF54A	T	GD 3 B
SPF55B	T	IC 1 D
SPF55B	T	ID 1 C
SPF58A	T	BB 3 A
SPF58A8	T	BW 1 B
SPF60A	S	CJ 3 B
SPF61A	T	NB 0 B
SPF62B	S	CH 0 B
SPF63	T	BE 0 B
SPF66A	T	KA 1 B
SPF66A	T	NA 4 A
SPF67B	T	IF 4 C
SPF67C	T	IF 2 C
SPF72A	T	KA 3 B
SPF75A1		BX 3 B
SPF75A2		BX 3 B
SPF76A1		JG 2 C
SPF81A	T	CI 4 C
SPF81A1	T	CI 3 C
SPF82A	T	BW 1 C
SPF84B1		AB 4 C
SPF91A	T	CD 0 B
SPF92A	T	CD 1 B
SPF144A		FA 4 B
SPFAA2	S	CJ 4 B
SPFS146B	T	BA 1 B
SPGC3A1	T	HA 1 B

Volvo Truck Corporation

Document title  
WIRING DIAGRAM TYPE OLDocument type  
PRODUCT SCHEMATIC

Document No

24403869

Issue

01

Volume

2 (2)

Page

52 (63)

0

1

2

3

4

0

1

2

3

4

## REFERENCES

REF	DESCRIPTION	PAGE
SPHA5A1		BX 0 C
SPHA5A3		BX 2 C
SPHA6A1		BX 0 B
SPHA6A3		BX 2 B
SPHAB11	T	BE 2 B
SPHBA8	T	BE 2 D
SPHBA8C	T	BG 2 D
SPHBA9	T	BE 2 D
SPHBA9C	T	BG 2 D
SPHBB8	T	BE 2 D
SPHBB8C	T	BG 2 D
SPHBB9	T	BE 3 D
SPHBB9C	T	BG 2 D
SPHE18		CA 2 D
SPJ1939H1		BX 1 C
SPJ1939H2		BX 1 D
SPJ1939H5		BX 2 C
SPJ1939H6		BX 3 C
SPJ1939H8		BX 4 C
SPJ1939L1		BX 1 C
SPJ1939L2		BX 1 D
SPJ1939L5		BX 2 C
SPJ1939L6		BX 3 C
SPJ1939L8		BX 4 C
splice407_509	S	KA 1 B
splice408_509	S	KA 1 A
SPN101	T	BP 2 C
SPN103	T	DD 2 C
SPN103B	T	BB 0 B
SPN103D	T	DE 1 C
SPN105B	T	BH 3 B
SPN105B	T	BP 2 B
SPN110	T	DD 1 B
SPN110A	T	DD 1 C
SPN112	T	DC 2 C
SPN113	T	BB 1 B
SPN117	T	DD 2 C
SPN117B	T	DE 1 B
SPN123	T	DD 0 C
SPN124CM	T	DD 2 C
SPN130CM	T	BP 1 B
SPN131	S	DC 1 C
SPN134	T	DD 1 D
SPN142	T	DD 1 C
SPN145	T	DD 3 C
SPN158	T	DC 2 C
SPN158A	S	DC 2 D
SPN163	T	DD 1 C
SPN163B	T	DD 2 A
SPN163E	S	FD 1 C

Volvo Truck Corporation

Document title  
WIRING DIAGRAM TYPE OLDocument type  
PRODUCT SCHEMATIC

Document No

24403869

Issue

01

Volume

2 (2)

Page

53 (63)

0

1

2

3

4

0

1

2

3

4

## REFERENCES

REF	DESCRIPTION	PAGE
SPN163F		FD 3 C
SPN163G	S	FD 2 C
SPN165	T	DD 3 C
SPN201	T	DD 2 A
SPNA23	T	BE 3 B
SPNA24	T	BE 3 B
SPS564FA1		BX 1 E
SPS564FA3		BX 1 E
SPU75A		NA 1 C
SPURDF	S	CD 1 A
SPX1A	S	AD 3 D
SPX1A	S	BE 0 C
SPX1A	S	CG 1 C
SPX1A	S	CI 1 C
SPX1A	S	FC 1 D
SPX1A3	S	AD 1 C
SPX1E9	T	EA 0 A
SPX1M	T	AD 3 C
SPX2A1	T	AD 3 C
SPX2A1	T	BA 3 C
SPX2A1	T	DE 0 D
SPX2A2	T	DE 0 D
SPX2A3	T	AD 3 C
SPX2A3	T	BA 0 C
SPX2A3	T	DD 0 E
SPX2A4	T	GD 2 B
SPX2A4	T	GP 2 E
SPX2A6	T	AD 3 C
SPX2A6	T	NA 2 B
SPX2A33	T	AD 3 D
SPX2A42	S	GA 1 E
SPX2A42	S	GD 4 D
SPX2A74	T	BE 4 D
SPX2A104	T	FD 0 C
SPX2A121	S	DD 1 B
SPX2A121	S	FB 1 D
SPX2A121	S	FC 0 C
SPX2A121	S	GD 4 B
SPX2A121	S	GH 3 D
SPX2A121	S	ID 2 B
SPX2A121	S	IE 2 B
SPX2A121	S	IF 1 D
SPX2A200	S	BA 3 C
SPX2A200	S	BD 2 C
SPX2A200	S	EA 3 B
SPX2A200	S	GA 1 C
SPX2A200	S	GH 3 D
SPX2A200	S	GP 0 C
SPX2A200	S	IC 2 C
SPX2A200	S	ID 1 B

Volvo Truck Corporation

Document title  
WIRING DIAGRAM TYPE OLDocument type  
PRODUCT SCHEMATIC

Document No

24403869

Issue

01

Volume

2 (2)

Page

54 (63)

0

1

2

3

4

0

1

2

3

4

## REFERENCES

REF	DESCRIPTION	PAGE
SPX2A200	S	IE 1 C
SPX2B	T	AD 3 B
SPX2B1	T	AD 3 B
SPX2B1	T	BD 1 B
SPX2B1	T	EA 2 A
SPX2B1	T	IE 2 A
SPX2B2	T	AA 2 E
SPX2B2	T	AB 3 D
SPX2B2	T	AD 3 B
SPX2B2	T	BE 3 A
SPX2B2	T	BY 3 C
SPX2B2	T	GP 3 E
SPX2B2	T	KA 2 D
SPX2B3	T	AD 3 B
SPX2B3	T	GA 2 D
SPX2B3	T	GQ 0 D
SPX2B3	T	NA 3 C
SPX2B4		JG 3 C
SPX2C	T	KC 2 D
SPX2D16	S	GD 1 D
SPX2G4	S	BE 1 E
SPX2G10	S	BE 0 E
SPX2G13	S	BE 4 C
SPX2N109B	S	FD 1 D
SPX2N109F	S	FD 3 D
SPX3A	T	AD 3 B
SPX3A1	T	AD 3 B
SPX3A1	T	CA 0 B
SPX3A1	T	DD 2 C
SPX3A1	T	FB 0 B
SPX3A1	T	GA 1 D
SPX3A1	T	NB 3 C
SPX3A2	T	AC 1 D
SPX3A2	T	AD 3 B
SPX3A2	T	FC 1 C
SPX3A2	T	GA 4 D
SPX3A8		BX 0 D
SPX3A10		BX 1 D
SPX3B	T	AD 3 A
SPX3B	T	BA 2 E
SPX3B	T	BE 1 B
SPX3B	T	BG 2 B
SPX3B	T	BP 1 B
SPX3B	T	EA 2 B
SPX3B2	T	AD 3 A
SPX3B2	T	BA 3 E
SPX3B2	T	DD 0 C
SPX3B3	T	AD 3 A
SPX3B3	T	BG 1 A
SPX3B4	T	BG 2 A

Volvo Truck Corporation

Document title  
WIRING DIAGRAM TYPE OLDocument type  
PRODUCT SCHEMATIC

Document No

24403869

Issue

01

Volume

2 (2)

Page

55 (63)

0

1

2

3

4

0

1

2

3

4

## REFERENCES

REF	DESCRIPTION	PAGE
SPX3C	T	AD 3 B
SPX3C	T	BG 0 B
SPX3C	T	GH 4 E
SPX3C	T	GQ 1 D
SPX3H	T	AD 3 A
SPX3H	T	GD 4 E
SPX4A	T	AD 3 D
SPX4A	T	BE 1 B
SPX4A	T	CI 2 D
SPX4A	T	FB 0 D
SPX4A	T	IC 2 D
SPX4A	T	ID 1 D
SPX4A2	T	AD 4 D
SPX4A2	T	HA 0 C
SPX4A3	T	IC 1 D
SPX4A3	T	ID 3 D
SPX4A5	T	BE 1 B
SPX4A6	T	BE 3 A
SPX4A17	T	AD 4 D
SPX4A17	T	BB 1 B
SPX4A17	T	GA 2 D
SPX4A17	T	NB 1 C
SPX4A18	T	CI 2 C
SPX4B	T	AD 3 D
SPX4B	T	GD 2 E
SPX4C	T	AD 3 D
SPX4C	T	GD 4 E
SPX4C	T	GH 2 E
SPX4C	T	KA 1 D
SPX4D	T	AD 3 D
SPX4D	T	XA 1 D
SPX4D	T	XB 2 D
SPX71D1	S	CJ 4 B
SPXA1	S	AD 1 B
SPXF1A1	S	AD 1 C
SPXF1A1	S	CD 0 E
SPXF1A1	S	FB 0 E
SPXF1A1	S	HA 0 E
SPXF1A2	S	AD 1 C
SPXF1A2	S	FD 2 E
SPXF1A2	S	GA 4 D
SPXF1A2	S	GF 2 B
SPXF1A3	S	GF 2 D
SPXF1A11	S	FB 2 E
SPXF1A11	S	GF 1 E
SPXF1A11A2	S	GF 2 D
SPXF1A14	S	AD 0 C
SPXF1A14	S	FA 2 E
SPXF1A14	S	GF 2 E
SPXF1A15	S	CG 1 E

Volvo Truck Corporation

Document title  
WIRING DIAGRAM TYPE OLDocument type  
PRODUCT SCHEMATIC

Document No

24403869

Issue

01

Volume

2 (2)

Page

56 (63)

0

1

2

3

4

0

1

2

3

4

## REFERENCES

REF	DESCRIPTION	PAGE
SPXF1A15	S	GF 2 D
SPXF1A16		BX 2 D
SPXF1A17	S	CG 1 D
SPXF1A24		FA 4 C
SPXF1C	S	AD 1 C
SPXF1C1	S	AD 1 C
SPXF1C1	S	CA 2 C
SPXF1C2	S	AD 1 C
SPXF1C2	S	CA 2 C
SPXF1C2	S	CH 4 C
SPXN109J	S	FD 2 D
SSCTS:A		GH 0 C
SSCTS:B		GH 0 C
SSCTS:C		GH 0 C
SSCTS:D		GH 0 C
SSCTS:E		GH 0 C
SSCTS:F		GH 0 E
SSCTS:G		GH 1 D
SSCTS:H		GH 1 D
SSCTS:J		GQ 2 C
SSCTS:K		GQ 1 C
T30_1_100	J1939	BG 2 C
T30_1_158	GXL_0.8_2	CD 4 B
T30_1_175	RADXL_0.8_2	XE 2 C
T30_1_271		BY 2 B
T30_1_347	J1939	BB 1 D
T30_1_399	J1939	BB 1 C
T30_1_872	J1939	XB 4 D
T30_1_1057	J1939	EE 3 C
T30_1_1117	J1939	XA 3 D
T30_1_1872	J1939	XA 3 D
T30_1_2830	J1939	BB 1 C
T30_1_Safety_Lane_Departure_v2	J1939	JG 3 C
T30_2_158	GXL_0.8_2	CD 3 B
T30_2_175		BW 1 C
T30_2_872	RADXL_0.8_2	XB 3 E
T30_2_982	J1939	XA 3 A
T30_2_1117	J1939	XA 3 D
T30_2_2384	GXL_0.8_2	CA 3 D
T30_2_2830	J1939	BB 0 C
T30_2_Safety_Lane_Departure_v2	twisted_pair	JG 1 B
T30_3_100	J1939	BE 2 D
T30_3_175	J1939	XE 2 C
T30_3_872	J1939	XB 2 D
T30_3_982	PROPRIETARY J1939	BX 1 C
T30_3_1057	J1939	JG 2 B
T30_3_1117	J1939	XA 3 D
T30_3_Aftertreatment_V1	GXL_0.8_2	CH 1 B
T30_3_Safety_Object_Sense_v1	PROPRIETARY J1939	BX 1 D
T30_4_100	J1939	XA 3 B

Volvo Truck Corporation

Document title  
WIRING DIAGRAM TYPE OLDocument type  
PRODUCT SCHEMATIC

Document No

24403869

Issue

01

Volume

2 (2)

Page

57 (63)

0

1

2

3

4

0

1

2

3

4

## REFERENCES

REF	DESCRIPTION	PAGE
T30_4_175	J1939	XE 2 B
T30_4_271	30 TWISTS PER METER	BY 2 D
T30_4_538	GXL_0.8_2	XA 4 D
T30_4_872	J1939	XB 4 B
T30_4_982	J1939	BX 0 B
T30_4_1057	J1939	JG 2 C
T30_4_1117	J1939	XA 3 D
T30_4_Safety_Lane_Departure_v2	J1939	JG 3 B
T30_4_Safety_Object_Sense_v1	PROPRIETARY J1939	BX 1 B
T30_5_100	J1939	XA 3 D
T30_5_175	J1939	XE 3 C
T30_5_271	30 TWISTS PER METER	BY 2 C
T30_5_872	RADXL_0.8_2	XB 2 E
T30_5_982	PROPRIETARY J1939	BX 1 C
T30_5_Safety_Lane_Departure_v2	PROPRIETARY J1939	JG 2 D
T30_6_175	twisted_pair	BW 2 C
T30_6_271	30 TWISTS PER METER	BY 2 C
T30_6_872	RADXL_0.8_2	XB 1 E
T30_7_100	J1939	XA 3 C
T30_7_175	RADXL_0.8_2	XE 1 C
T30_7_271	30 TWISTS PER METER	BY 2 B
T30_7_872	J1939	XB 4 D
T30_7_Safety_Object_Sense_v1	PROPRIETARY J1939	BX 0 C
T30_8_100	J1939	XA 3 B
T30_8_175	twisted_pair	XE 1 C
T30_8_271	30 TWISTS PER METER	BY 2 B
T30_8_872	RADXL_0.8_2	XB 3 E
T30_9_100	J1939	XA 3 B
T30_9_271	30 TWISTS PER METER	BY 2 B
T30_9_872	RADXL_0.8_2	XB 4 E
T30_9_1057	J1939	XA 3 D
T30_10_100	J1939	BG 2 D
T30_10_872	J1939	XB 1 C
T30_10_1057	J1939	XA 4 D
T30_10_2339	GXL_0.8_2	XA 3 E
T30_11_100	J1939	XA 3 B
T30_11_872	J1939	XB 4 C
T30_11_1057	J1939	JG 2 D
T30_12_100	J1939	XA 2 C
T30_12_872	J1939	XB 4 B
T30_12_1057	J1939	JG 2 D
T30_13_872	J1939	XB 4 D
T30_13_1057	J1939	JG 2 B
T30_13_2339	GXL_0.8_2	XA 4 E
T30_13_Safety_Object_Sense_v1	PROPRIETARY J1939	BX 1 C
T30_14_872	RADXL_0.8_2	XB 3 E
T30_15_872	J1939	XB 4 D
T30_16_872	J1939	XB 4 B
T30_17_872	J1939	XB 4 A
T30_17_2339	GXL_0.8_2	CA 3 C

Volvo Truck Corporation

Document title  
WIRING DIAGRAM TYPE OLDocument type  
PRODUCT SCHEMATIC

Document No

24403869

Issue

01

Volume

2 (2)

Page

58 (63)

0

1

2

3

4



0

1

2

3

4

## REFERENCES

REF	DESCRIPTION	PAGE
T30_18_872	RADXL_0.8_2	CJ 1 C
T30_18_2339	GXL_0.8_2	CA 3 C
T30_19_872	J1939	XB 4 C
T30_19_2339	GXL_0.8_2	CA 3 D
T30_20_872	J1939	XB 4 B
T30_21_175	J1939	XA 3 C
T30_21_872	J1939	DD 4 E
T30_21_2339	GXL_0.8_2	CA 3 C
T30_22_2339	J1939	DD 4 D
T30_23_175	J1939	XA 3 C
T30_23_872	twisted pair	BW 2 B
T30_24_872	J1939	XB 3 B
T30_25_872	J1939	BG 2 D
T30_27_872	J1939	EA 3 B
T30_28_2339	J1939	EA 3 B
T30_29_2339	J1939	EA 3 C
T30_31_2339	J1939	BB 1 C
TC40-1_57		DC 0 B
TC40-1_100		BE 2 D
TC40-1_175		BW 1 C
TC40-1_538		CH 2 C
TC40-1_863		EA 2 D
TC40-1_982		EE 1 D
TC40-1_1117	W/O_W/O_W/O_W/O_TXL	EF 1 D
TC40-1_2968		DC 0 B
TC40-2_57		DC 0 B
TC40-2_100		BG 2 C
TC40-2_175		XC 4 C
TC40-2_271		BY 2 D
TC40-2_538		CA 0 D
TC40-2_863		EA 2 D
TC40-2_982	twisted pair	EF 1 B
TC40-2_2968		DC 0 B
TC40-3_57		DC 0 B
TC40-3_90		XC 1 B
TC40-3_100		BG 2 D
TC40-3_175		XC 4 D
TC40-3_271		BY 2 D
TC40-3_538		CH 3 C
TC40-3_863		EA 2 C
TC40-3_982	twisted pair	EF 1 D
TC40-3_2968		DC 0 B
TC40-4_90		XC 1 B
TC40-4_100		BE 2 D
TC40-4_175		XC 4 C
TC40-4_271		BY 2 D
TC40-4_863		EA 2 D
TC40-4_982	twisted pair	EF 2 D
TC40-4_2339		BB 1 D
TC40-5_175		XC 4 C

Volvo Truck Corporation

Document title  
WIRING DIAGRAM TYPE OLDocument type  
PRODUCT SCHEMATIC

Document No

24403869

Issue

01

Volume

2 (2)

Page

59 (63)

0

1

2

3

4

0

1

2

3

4

## REFERENCES

REF	DESCRIPTION	PAGE
TC40-5_863		EA 2 D
TC40-5_982	twisted pair	EF 1 C
TC40-5_2384		EA 0 D
TC40-6_90		BB 1 D
TC40-6_175		XC 4 B
TC40-6_863		EA 2 D
TC40-6_982		EE 2 D
TC40-6_2384		EA 1 D
TC40-6_3180		DE 1 D
TC40-7_57		DC 0 D
TC40-7_90		XC 4 B
TC40-7_175		XC 3 D
TC40-7_863		EA 2 C
TC40-7_982		EE 2 B
TC40-7_3180		DD 2 D
TC40-8_57		DC 0 D
TC40-8_863		EA 2 D
TC40-8_982		EE 1 B
TC40-9_57		DC 0 D
TC40-9_175		XC 4 B
TC40-9_982		EE 0 B
TC40-9_3180		DD 4 D
TC40-10_57		DC 0 D
TC40-10_982		EE 0 C
TC40-11_175		XC 4 E
TC40-11_982		EE 1 C
TC40-12_175		DD 2 D
TC40-12_982		EE 2 C
TC40-12_2339		GG 1 C
TC40-13_175		XC 4 C
TC40-13_982		EE 1 D
TC40-14_175		DE 2 D
TC40-14_982		EE 2 D
TC40-15_175		DD 3 E
TC40-15_982	40T_GXL	EE 0 B
TC40-16_175		XC 1 D
TC40-16_982	40T_GXL	EE 1 D
TC40-17_175		XD 2 C
TC40-17_982	40T_GXL	EE 2 D
TC40-18_175		XC 1 D
TC40-18_982		EE 4 D
TC40-19_175		XC 2 B
TC40-20_175		XC 1 A
TC40-20_982		EE 4 D
TC40-21_175		XC 2 C
TC40-21_982	40T_GXL	EE 4 D
TC40-22_175		XC 1 C
TC40-23_175		XC 1 B
TC40-24_175		XC 2 C
TC40-25_175		XD 3 C

Volvo Truck Corporation

Document title  
WIRING DIAGRAM TYPE OL

Document No

Issue

Volume

Page

Document type  
PRODUCT SCHEMATIC

24403869

01

2 (2)

60 (63)

0

1

2

3

4

## REFERENCES

REF	DESCRIPTION	PAGE
TC40-27_175		XC 1 C
TC40-29_175		XC 1 D
TC40-39_2339		EA 1 D
TC40-40_2339		EA 1 C
TC40-42_2339		EA 0 C
TC40-44_2339		EA 0 D
TC40-45_2339		EA 1 B
TC40-46_2339		EA 1 C
TC40-48_2339		EA 1 B
TC40-50_2339		EA 1 C
TC40-51_2339		EA 1 B
TC40-52_2339		EA 1 B
TLBU:A		GF 3 C
TLBU:B		GF 3 C
TRPTO:A		FD 2 B
TRPTO:B		FD 1 C
TRPTO:C		FD 1 E
V03	Diode	GD 1 C
V08	Diode	BA 1 B
V09	Diode	BA 2 B
V33	Diode	BF 2 C
V34	Diode	DD 3 C
V35	DIODE, METHANE DETECTION	CI 0 D
WL:A		GD 0 B
WL:B		GD 1 B
WL:C		GD 1 D
X0C	SPLICE PACK, ILLUMINATION, SEE DIAGRAM GH	BA 3 A
X0C	SPLICE PACK, ILLUMINATION, SEE DIAGRAM GH	GH 4 A
X0C	SPLICE PACK, ILLUMINATION, SEE DIAGRAM GH	HA 1 A
X01	Connector, vehicle diagnostics	XD 2 C
X1_C2	STUD, CAB GND #1	AD 3 C
X1_C5	STUD, CAB GND #1 ALLISION	AD 3 D
X01A	Connector, vehicle diagnostics 16 poles	XA 1 C
X01A	Connector, vehicle diagnostics 16 poles	XB 2 D
X01A	Connector, vehicle diagnostics 16 poles	XC 1 D
X01A	Connector, vehicle diagnostics 16 poles	XD 2 C
X2_C1	BOLT, LEFT CAB GND #2 STANDARD	AD 3 C
X2_C4	BOLT, LEFT CAB GND #2 MAIN	AD 3 C
X2_C6		AD 3 B
X3_C1	BOLT, RIGHT CAB GROUND #3	AD 3 A
X3_C2	BOLT, RIGHT CAB GROUND #3	AD 3 B
X4_C1	X4 JUNCTION, TERMINAL,	AD 2 D
X4_C2	STUD, CAB GND #1	AD 2 D
X4_C3		AD 2 D
X06D	CONNECTOR ALLISON BODY BUILDER	BH 0 C
X07A	POWER OUTLET #1	KC 1 C
X10	B+ pass through, Cab	AC 3 E
X10_C1	L.H. CAB B+ STUD	AC 4 E
X11	Connector, Engine	CA 0 C
X11	Connector, Engine	HA 0 E

Volvo Truck Corporation

Document title  
WIRING DIAGRAM TYPE OLDocument type  
PRODUCT SCHEMATIC

Document No

24403869

Issue

01

Volume

2 (2)

Page

61 (63)

## REFERENCES

REF	DESCRIPTION	PAGE
X11B	CONNECTORS CUMMINS '18 ISL G ENGINE	CJ 1 C
X18	Fusible Link	AD 1 B
X21B	Socket, Body builder connector	BC 0 C
X21F	BODYLINK TMC RP170 POWERTRAIN	BP 0 D
X21G	BODYLINK TMC RP170 LIGHTING	BN 2 C
X21H	BODYLINK TMC RP170 POWER	BN 0 C
X34	JUNCTION, CB BINDING POST	KC 2 C
X43_C1	WORK LAMP, TERMINAL, LEFT "+"	GD 0 C
X43_C2	WORK LAMP, TERMINAL, LEFT "-"	GD 0 C
X44_C1	WORK LAMP, TERMINAL, RIGHT "+"	GD 1 B
X44_C2	WORK LAMP, TERMINAL, RIGHT "-"	GD 1 C
X71	GROUND, ENGINE BLOCK, ALTERNATOR, PRE-HE	AD 0 D
X110	Split Connector, ground	AD 2 B
X111	Split Connector, ground	AD 4 C
X111	Split Connector, ground	BC 0 C
X111	Split Connector, ground	CI 1 D
X111	Split Connector, ground	GD 2 B
X111	Split Connector, ground	HA 1 B
X135	Chassis Ground Stud	AD 1 C
X136	Cab Passthrough Ground Stud	AD 2 C
X137	Cab Ground Stud	AD 2 C
X137A	STUD CAB GROUND	AD 2 D
X140	Battery Box Ground Stud	AD 1 B
X141	CONNECTOR SHORE POWER BLOCK HEATER	CC 2 B
X175	JUNCTION BLOCK 14 POST MAIN	GG 2 D
X175	JUNCTION BLOCK 14 POST MAIN	NA 1 A
X178	JUNCTION BLOCK 5 POST OPTIONS	NB 1 B
X179	JUNCTION BLOCK 4 POST BODY BUILDER	KA 0 C
X179	JUNCTION BLOCK 4 POST BODY BUILDER	NB 3 D
X194	CONNECTOR, TGW BODYBUILDER INTERFACE	BW 1 D
X197	CONNECTOR EATS	BE 1 A
X197	CONNECTOR EATS	CA 2 B
X197	CONNECTOR EATS	CH 0 D
Y05	Solenoid valve, bogie lift	FB 0 D
Y11	Solenoid valve unit, ABS, front left	EA 0 B
Y11	Solenoid valve unit, ABS, front left	EE 1 B
Y12	Solenoid valve unit, ABS, front right	EA 1 B
Y12	Solenoid valve unit, ABS, front right	EE 0 B
Y13	Solenoid valve unit, ABS, rear left	EA 1 D
Y13	Solenoid valve unit, ABS, rear left	EE 1 B
Y14	Solenoid valve unit, ABS, rear right	EA 2 D
Y14	Solenoid valve unit, ABS, rear right	EE 0 E
Y15	Solenoid valve unit, ABS, lhs. 3:rd axle	EA 3 D
Y15	Solenoid valve unit, ABS, lhs. 3:rd axle	EE 2 E
Y16	Solenoid valve unit, ABS, rhs. 3:rd axle	EA 3 D
Y16	Solenoid valve unit, ABS, rhs. 3:rd axle	EE 2 E
Y18A	Solenoid valve, PTO1 (Power Take Off)	FC 1 D
Y35	Solenoid valve, engine cooling fan	CA 1 C
Y35E	SOLENOID ENGINE FAN E-VISCO	CJ 1 D
Y42	Clutch, magnetic, air conditioning compr	HA 0 E

Volvo Truck Corporation

Document title  
WIRING DIAGRAM TYPE OLDocument type  
PRODUCT SCHEMATIC

Document No

24403869

Issue

01

Volume

2 (2)

Page

62 (63)

0

1

2

3

4

## REFERENCES

REF	DESCRIPTION	PAGE
Y51	Solenoid valve, Air dryer	FA 4 C
Y57	Solenoid valve, Automatic Traction Contr	EA 1 D
Y57	Solenoid valve, Automatic Traction Contr	EE 3 E
Y57C	SOLENOID VALVE SA TRACTION HSA	EF 0 C
Y62	Solenoid valve, TCM backup	DC 0 C
Y81	Solenoid valve, AdBlue tank heating	CH 2 D
Y95	SOLENOID HIGH NG PRESSURE LOCKOFF	CG 2 D
Y137	Mega valve unit	FB 1 D
Y168	SOLENOID, PARKER PTO	FD 3 C
Z10	ONBOARD DIAGNOSTIC CONNECTOR VENDOR ENGIN	XB 1 C
Z10	ONBOARD DIAGNOSTIC CONNECTOR VENDOR ENGIN	XE 3 C

Volvo Truck Corporation

Document title  
WIRING DIAGRAM TYPE OL

Document type  
PRODUCT SCHEMATIC

Document No

24403869

Issue

01

Volume

2 (2)

Page

63 (63)

0

1

2

3

4

0

1

2

3

4

## RELAYS

RELAY	DESCRIPTION	PAGE
RLY01	RELAY EMS #1	AB 3 C
RLY02	RELAY EMS #2	AA 2 C
RLY03	RELAY IGN. #1	AA 0 B
RLY04	RELAY IGN. #3	AA 3 C
RLY05	RELAY HIGH BEAM	GA 1 C
RLY06	RELAY, EMERGENCY STOP LAMP	GA 3 B
RLY10	RELAY, LEFT/RIGHT SW. PWR.	BA 1 B
RLY11	RELAY TRAILER TAIL LAMP	GG 2 B
RLY12	RELAY TRAILER STOP LAMP	GG 3 B
RLY13	RELAY, CAB AND TRAILER CLEARANCE LAMP	GA 1 C
RLY14	RELAY, HORN	GQ 2 C
RLY15	RELAY HAZARD BYPASS	GA 4 C
RLY016A	RELAY WINDSHIELD WIPER RH LOW	GP 2 B
RLY016B	RELAY WINDSHIELD WIPER RH HIGH	GP 2 B
RLY016C	RELAY WINDSHIELD WIPER LH LOW	GP 3 B
RLY016D	RELAY WINDSHIELD WIPER LH HIGH	GP 3 B
RLY17	RELAY REVERSE POWER	DD 3 B
RLY19	El. adjustable seat (optional fan and hea	GD 3 B
RLY28	RELAY, CB BINDING POST	KC 2 B
RLY29	RELAY, NEUTRAL POWER	NB 2 B
RLY34	RELAY, PRE-EMS	AA 1 B
RLY35	RELAY, HVAC CAB	HA 0 B
RLY36	RELAY START CNTL. 1	AC 1 C
RLY38	RELAY, LOW BEAM LEFT	GD 0 B
RLY39	RELAY, LOW BEAM RIGHT	GD 1 B
RLY45	RELAY PTO ENABLE	DD 4 B
RLY46	RELAY RANGE PTO	DD 3 B
RLY47	RELAY RETARDER	DD 2 B
RLY48	RELAY STOP LAMPS	DD 2 B

RELAY	DESCRIPTION	PAGE
RLY49	RELAY AC CLUTCH	HA 0 C
RLY52	RELAY, HIGH BEAM	GA 1 B
RLY54	RELAY METHANE DETECTOR	CI 0 B
RLY58	RELAY BEACON LAMP PTO	FC 1 B
RLY59	RELAY BEACON LPS REVERSE	FC 2 B
RLY60	RELAY, PARK BRAKE STOP LAMP	GA 3 B
RLY61	RELAY LIFT AXLE REVERSE	FB 0 A
RLY62	RELAY, REVERSE BODY POWER	NB 3 B
RLY63	RELAY, POWER INDICATOR	GA 3 D
RLY64	1 DETECT METHANE RELAY RELAY, SPARE	NA 0 C
RLY68	RELAY, ENGINE COMP#1	CA 0 B
RLY70	RELAY, TPS L-R REF.	BB 4 C
RLY71	RELAY, TPS L-R IVS	BB 3 B
RLY72	RELAY DIRECTIONAL LAMPS L-R	GH 0 B
RLY73	RELAY LEFT COMB. STOP TURN LAMPS	GH 0 B
RLY74	RELAY HIGH BEAM SW. L-R	GH 1 B
RLY75	RELAY, ALLISON L-R SHIFT INHIBIT	BB 1 B
RLY76	RELAY ALLISON L/R SERVICE BRAKE INHIBIT	DE 2 B
RLY77	RELAY AUTO NEUTRAL PACKER	DE 0 C
RLY78	RELAY AUTO NEUTRAL WORK BRAKE	DE 1 C
RLY80	RELAY, WORK LAMPS LEFT	GD 0 A
RLY81	RELAY, WORK LAMPS RIGHT	GD 2 B
RLY89	RELAY, HEATER HIGH FAN SPEED	HA 1 C
RLY91	#1 (optional AUX. El. FAN RELAY adjustabl	CD 0 C
RLY92	#2 (optional AUX. El. FAN RELAY adjustabl	CD 1 C
RLY95	(optional 2 El. INTERRUPT RELAY START adj	BP 1 B
RLY96	RELAY RIGHT COMB. STOP TURN LAMPS	GH 1 B
RLY99	RELAY, METHANE DETECTION	CI 0 C
RLY113	RELAY, L/R MPH/RPM BRAKE STATUS CONTROLLE	DE 4 B

Volvo Truck Corporation

Document title  
WIRING DIAGRAM TYPE OLDocument type  
PRODUCT SCHEMATIC

Document No

24403869

Issue

01

Volume

2 (2)

Page

11 (63)

0

1

2

3

4

SPLICES

SPLICE	PAGE
SPAD1A1 ( )	EF 2 B
SPAD4A1 ( )	EF 3 B
SPAD7A1 ( )	EF 1 C
SPAD8A1 ( )	EF 1 C
SPAD10A1 ( )	EF 1 C
SPAD11A1 ( )	EF 1 C
SPCA11 (T)	BE 3 C
SPCA11 (T)	BG 3 B
SPCA11 (T)	GD 2 B
SPCA15 (T)	BE 1 B
SPCB1 (T)	BA 1 E
SPCB10 (T)	BB 3 D
SPCB11 (T)	BA 2 E
SPCB13A (T)	BB 2 B
SPCB13A5 (T)	BB 3 B
SPCB13A11 (T)	BB 2 B
SPCB16 (T)	CD 1 C
SPCB19 (T)	BB 2 D
SPCB19D (S)	DE 3 B
SPCB19E (S)	DE 2 B
SPCB19F (T)	DE 3 D
SPCB19G (T)	BQ 3 C
SPCB22 (T)	BB 2 D
SPDL1H (S)	XA 3 E
SPDL1H1 (S)	XA 3 D
SPDL1H1 (S)	XB 4 D
SPDL1H2 (S)	XA 3 D
SPDL1H2 (S)	XB 4 D
SPDL1H3 (S)	XA 3 B
SPDL1H3 (S)	XB 4 C
SPDL1H4 (S)	XA 3 B
SPDL1H4 (S)	XB 4 B
SPDL1H5 (S)	XA 3 B
SPDL1H5 (S)	XB 4 B
SPDL1H6 (S)	XA 3 B
SPDL1H6 (S)	XB 4 B
SPDL1H7 (S)	XA 3 C
SPDL1H7 (S)	XB 4 C
SPDL1H8 (S)	XB 4 A
SPDL1H9 ( )	XA 3 D
SPDL1H12 ( )	XA 3 D
SPDL1H15 ( )	JG 2 B
SPDL1H16 ( )	JG 2 C
SPDL1H17 ( )	JG 2 C
SPDL1HN10 (S)	XB 3 E
SPDL1HN12 (S)	XB 3 E
SPDL1HN14 (S)	XB 2 E
SPDL1L (S)	XA 3 E
SPDL1L1 (S)	XA 3 D
SPDL1L1 (S)	XB 4 D

SPLICE	PAGE
SPDL1L2 (S)	XA 3 C
SPDL1L2 (S)	XB 4 D
SPDL1L3 (S)	XA 3 C
SPDL1L3 (S)	XB 4 C
SPDL1L4 (S)	XA 3 B
SPDL1L4 (S)	XB 4 B
SPDL1L5 (S)	XA 3 B
SPDL1L5 (S)	XB 4 B
SPDL1L6 (S)	XA 3 B
SPDL1L6 (S)	XB 4 B
SPDL1L7 (S)	XA 3 C
SPDL1L7 (S)	XB 4 C
SPDL1L8 (S)	XB 4 B
SPDL1L9 ( )	XA 3 D
SPDL1L12 ( )	XA 3 D
SPDL1L15 ( )	JG 2 B
SPDL1L16 ( )	JG 3 B
SPDL1L17 ( )	JG 3 C
SPDL1LN10 (S)	XB 3 E
SPDL1LN12 (S)	XB 3 E
SPDL1LN14 (S)	XB 2 E
SPDL2H1 (S)	CH 2 B
SPDL2H2 (S)	XC 1 B
SPDL2H3 (S)	XC 1 C
SPDL2H4 (S)	XC 1 C
SPDL2H5 (S)	XC 1 D
SPDL2H6 (S)	XC 4 C
SPDL2H7 ( )	XC 1 B
SPDL2L1 (S)	CH 2 B
SPDL2L2 (S)	XC 2 B
SPDL2L3 (S)	XC 2 C
SPDL2L4 (S)	XC 2 C
SPDL2L5 (S)	XC 2 D
SPDL2L6 (S)	XC 4 C
SPDL2L7 ( )	XC 2 B
SPDL4H (S)	BY 2 C
SPDL4H (S)	XD 2 B
SPDL4L (S)	BY 2 C
SPDL4L (S)	XD 2 B
SPDL5H101 ( )	BY 2 C
SPDL5H102 ( )	BY 2 B
SPDL5HB1 ( )	BB 1 C
SPDL5L101 ( )	BY 2 C
SPDL5L102 ( )	BY 2 B
SPDL5LB1 ( )	BB 1 C
SPDL7H1 (S)	CA 3 C
SPDL7L1 (S)	CA 3 C
SPDL10H1 (S)	XE 2 B
SPDL10H2 (S)	XE 1 B
SPDL10L1 (S)	XE 3 C

SPLICE	PAGE
SPDL10L2 (S)	XE 1 C
SPECHA1 (S)	CJ 2 D
SPECKA1 (S)	CJ 2 D
SPEMA28A1 (S)	CH 3 C
SPEMA49A (S)	CA 2 C
SPEMA54A1 (S)	CH 1 C
SPEMA59A1 (S)	CH 3 D
SPEMA62A (S)	CH 2 D
SPF2B (T)	GA 1 B
SPF2C (T)	GA 0 C
SPF2G (T)	GD 2 C
SPF2H (T)	GD 2 C
SPF3B (T)	GA 0 C
SPF3B7 (S)	GF 1 B
SPF3B8 ( )	GF 1 C
SPF3B20 (S)	GA 0 C
SPF3C (T)	GA 0 D
SPF3D (T)	GD 3 A
SPF3F (T)	BE 1 A
SPF3F (T)	BG 1 A
SPF3F (T)	CG 1 A
SPF3F (T)	DE 0 D
SPF3F (T)	GH 4 A
SPF3F (T)	KA 3 B
SPF3F (T)	NA 2 A
SPF3F1 (T)	BA 2 B
SPF3F69 (T)	FD 0 A
SPF3F74 (T)	BE 4 D
SPF3F100 (S)	DD 2 B
SPF3F100 (S)	FB 1 B
SPF3F100 (S)	FC 0 B
SPF3F100 (S)	GD 4 A
SPF3F100 (S)	GH 3 C
SPF3F100 (S)	ID 2 A
SPF3F100 (S)	IE 2 B
SPF3F100 (S)	IF 1 C
SPF3F110 (T)	BE 1 A
SPF3F110 (T)	DD 0 B
SPF3F116 (T)	BG 1 A
SPF3F200 (S)	BA 3 B
SPF3F200 (S)	BD 2 B
SPF3F200 (S)	EA 3 A
SPF3F200 (S)	EE 3 A
SPF3F200 (S)	GA 1 B
SPF3F200 (S)	GH 3 C
SPF3F200 (S)	GP 0 B
SPF3F200 (S)	IC 2 B
SPF3F200 (S)	ID 1 A
SPF3F200 (S)	IE 0 B
SPF3G (T)	GA 0 A

SPLICE	PAGE
SPF3H (T)	GA 2 B
SPF3J (T)	GA 0 C
SPF3K (T)	GA 0 D
SPF3M (S)	GD 4 B
SPF4B (T)	GA 2 B
SPF4B3 (S)	GH 2 D
SPF4B3C (S)	GH 2 E
SPF4C (T)	GD 3 C
SPF4D (T)	GD 4 C
SPF4E (T)	GD 4 C
SPF4EA5 ( )	JG 3 C
SPF4F (T)	GD 2 C
SPF4FA5 ( )	JG 3 C
SPF4G (T)	GD 3 D
SPF4H (T)	GD 3 C
SPF5A (T)	GA 4 B
SPF5A1 (S)	GA 4 B
SPF5B (T)	GA 4 C
SPF5B1 (S)	GA 4 C
SPF5B5 (T)	GA 4 C
SPF5D1 (S)	GF 2 B
SPF5E1 (S)	GF 1 B
SPF6A (T)	GH 3 B
SPF6D (T)	GH 4 B
SPF6E (S)	GH 3 D
SPF6E3 (T)	GH 3 E
SPF7A (T)	AC 0 B
SPF7C (T)	AC 1 B
SPF7D (T)	AC 1 C
SPF7D (T)	XB 1 C
SPF7D8A2 (S)	CD 3 B
SPF7D10 (T)	CI 0 C
SPF7G (T)	BF 2 B
SPF8A (T)	FB 2 B
SPF8A2 (S)	FB 3 B
SPF8B (T)	FB 4 D
SPF9B (T)	KC 2 B
SPF9D (T)	GA 2 D
SPF9D2 (S)	GA 3 D
SPF10A (T)	KA 3 B
SPF10A (T)	XA 2 B
SPF10A (T)	XB 2 B
SPF10C (T)	KA 3 C
SPF11A (T)	BY 1 B
SPF11A (T)	GG 1 B
SPF15A (T)	FC 1 B
SPF15B (T)	FC 2 C
SPF16A (T)	BA 0 B
SPF17A (T)	BA 2 B
SPF17C (T)	BA 1 D

SPLICE	PAGE
SPF17D (T)	BA 1 C
SPF17E (T)	BA 2 C
SPF18A (T)	BC 2 B
SPF19 (T)	BE 0 B
SPF19 (T)	BG 0 B
SPF20A (T)	IC 0 A
SPF20A (T)	ID 2 A
SPF21A (T)	GP 4 B
SPF22A (T)	GP 2 B
SPF23A (T)	GP 0 B
SPF23C (T)	GP 2 A
SPF23D (T)	GP 2 B
SPF25A (T)	HA 0 A
SPF25B (T)	HA 1 B
SPF27A (T)	GG 1 B
SPF27A4 (T)	CG 1 C
SPF29B (T)	AA 2 C
SPF30B (T)	FC 1 C
SPF31A (T)	DD 3 A
SPF31A9 (T)	DD 0 A
SPF31B (T)	DE 0 B
SPF31C (T)	DD 2 B
SPF33B (T)	GG 3 C
SPF34A (T)	NB 3 B
SPF34B (T)	NB 3 C
SPF34B1 (S)	GF 2 B
SPF34B10 ( )	GF 2 C
SPF35B (T)	GA 2 C
SPF35C (S)	GA 3 D
SPF35C1 (S)	GA 4 D
SPF35C3 (S)	GA 3 D
SPF36D (S)	GQ 1 B
SPF36D1 (T)	GQ 1 C
SPF37B (T)	GG 2 B
SPF38A (T)	CA 0 B
SPF38A4 (S)	CA 0 C
SPF39A (T)	GG 1 B
SPF41A (T)	CG 2 C
SPF42B (T)	DD 4 C
SPF43A (S)	CA 1 C
SPF44A (S)	FA 2 B
SPF45A (T)	NB 2 D
SPF47A (T)	NA 3 B
SPF52A (T)	HA 0 B
SPF54A (T)	GD 3 B
SPF55B (T)	IC 1 D
SPF55B (T)	ID 1 C
SPF58A (T)	BB 3 A
SPF58A8 (T)	BW 1 B
SPF60A (S)	CJ 3 B

A

A

B

B

C

C

D

D

E

E

Volvo Truck Corporation	Document title	24403869	01	2 (2)	12 (63)
	Document type				
	WIRING DIAGRAM TYPE OL				
	PRODUCT SCHEMATIC				

## SPLICES

SPLICE	PAGE
SPF61A (T)	NB 0 B
SPF62B (S)	CH 0 B
SPF63 (T)	BE 0 B
SPF66A (T)	KA 1 B
SPF66A (T)	NA 4 A
SPF67B (T)	IF 4 C
SPF67C (T)	IF 2 C
SPF72A (T)	KA 3 B
SPF75A1 ( )	BX 3 B
SPF75A2 ( )	BX 3 B
SPF76A1 ( )	JG 2 C
SPF81A (T)	CI 4 C
SPF81A1 (T)	CI 3 C
SPF82A (T)	BW 1 C
SPF84B1 ( )	AB 4 C
SPF91A (T)	CD 0 B
SPF92A (T)	CD 1 B
SPF144A ( )	FA 4 B
SPFAA2 (S)	CJ 4 B
SPFS146B (T)	BA 1 B
SPGC3A1 (T)	HA 1 B
SPHA5A1 ( )	BX 0 C
SPHA5A3 ( )	BX 2 C
SPHA6A1 ( )	BX 0 B
SPHA6A3 ( )	BX 2 B
SPHAB11 (T)	BE 2 B
SPHBA8 (T)	BE 2 D
SPHBA8C (T)	BG 2 D
SPHBA9 (T)	BE 2 D
SPHBA9C (T)	BG 2 D
SPHBB8 (T)	BE 2 D
SPHBB8C (T)	BG 2 D
SPHBB9 (T)	BE 3 D
SPHBB9C (T)	BG 2 D
SPHE18 ( )	CA 2 D
SPJ1939H1 ( )	BX 1 C
SPJ1939H2 ( )	BX 1 D
SPJ1939H5 ( )	BX 2 C
SPJ1939H6 ( )	BX 3 C
SPJ1939H8 ( )	BX 4 C
SPJ1939L1 ( )	BX 1 C
SPJ1939L2 ( )	BX 1 D
SPJ1939L5 ( )	BX 2 C
SPJ1939L6 ( )	BX 3 C
SPJ1939L8 ( )	BX 4 C
SPN101 (T)	BP 2 C

SPLICE	PAGE
SPN103 (T)	DD 2 C
SPN103B (T)	BB 0 B
SPN103D (T)	DE 1 C
SPN105B (T)	BH 3 B
SPN105B (T)	BP 2 B
SPN110 (T)	DD 1 B
SPN110A (T)	DD 1 C
SPN112 (T)	DC 2 C
SPN113 (T)	BB 1 B
SPN117 (T)	DD 2 C
SPN117B (T)	DE 1 B
SPN123 (T)	DD 0 C
SPN124CM (T)	DD 2 C
SPN130CM (T)	BP 1 B
SPN131 (S)	DC 1 C
SPN134 (T)	DD 1 D
SPN142 (T)	DD 1 C
SPN145 (T)	DD 3 C
SPN158 (T)	DC 2 C
SPN158A (S)	DC 2 D
SPN163 (T)	DD 1 C
SPN163B (T)	DD 2 A
SPN163E (S)	FD 1 C
SPN163F ( )	FD 3 C
SPN163G (S)	FD 2 C
SPN165 (T)	DD 3 C
SPN201 (T)	DD 2 A
SPNA23 (T)	BE 3 B
SPNA24 (T)	BE 3 B
SPS564FA1 ( )	BX 1 E
SPS564FA3 ( )	BX 1 E
SPU75A ( )	NA 1 C
SPURDF (S)	CD 1 A
SPX1A (S)	AD 3 D
SPX1A (S)	BE 0 C
SPX1A (S)	CG 1 C
SPX1A (S)	CI 1 C
SPX1A (S)	FC 1 D
SPX1A3 (S)	AD 1 C
SPX1E9 (T)	EA 0 A
SPX1M (T)	AD 3 C
SPX2A1 (T)	AD 3 C
SPX2A1 (T)	BA 3 C
SPX2A1 (T)	DE 0 D
SPX2A2 (T)	DE 0 D
SPX2A3 (T)	AD 3 C

SPLICE	PAGE
SPX2A3 (T)	BA 0 C
SPX2A3 (T)	DD 0 E
SPX2A4 (T)	GD 2 B
SPX2A4 (T)	GP 2 E
SPX2A6 (T)	AD 3 C
SPX2A6 (T)	NA 2 B
SPX2A33 (T)	AD 3 D
SPX2A42 (S)	GA 1 E
SPX2A42 (S)	GD 4 D
SPX2A74 (T)	BE 4 D
SPX2A104 (T)	FD 0 C
SPX2A121 (S)	DD 1 B
SPX2A121 (S)	FB 1 D
SPX2A121 (S)	FC 0 C
SPX2A121 (S)	GD 4 B
SPX2A121 (S)	GH 3 D
SPX2A121 (S)	ID 2 B
SPX2A121 (S)	IE 2 B
SPX2A121 (S)	IF 1 D
SPX2A200 (S)	BA 3 C
SPX2A200 (S)	BD 2 C
SPX2A200 (S)	EA 3 B
SPX2A200 (S)	GA 1 C
SPX2A200 (S)	GH 3 D
SPX2A200 (S)	GP 0 C
SPX2A200 (S)	IC 2 C
SPX2A200 (S)	ID 1 B
SPX2A200 (S)	IE 1 C
SPX2B (T)	AD 3 B
SPX2B1 (T)	AD 3 B
SPX2B1 (T)	BD 1 B
SPX2B1 (T)	EA 2 A
SPX2B1 (T)	IE 2 A
SPX2B2 (T)	AA 2 E
SPX2B2 (T)	AB 3 D
SPX2B2 (T)	AD 3 B
SPX2B2 (T)	BE 3 A
SPX2B2 (T)	BY 3 C
SPX2B2 (T)	GP 3 E
SPX2B2 (T)	KA 2 D
SPX2B3 (T)	AD 3 B
SPX2B3 (T)	GA 2 D
SPX2B3 (T)	GQ 0 D
SPX2B3 (T)	NA 3 C
SPX2B4 ( )	JG 3 C
SPX2C (T)	KC 2 D

SPLICE	PAGE
SPX2D16 (S)	GD 1 D
SPX2G4 (S)	BE 1 E
SPX2G10 (S)	BE 0 E
SPX2G13 (S)	BE 4 C
SPX2N109B (S)	FD 1 D
SPX2N109F (S)	FD 3 D
SPX3A (T)	AD 3 B
SPX3A1 (T)	AD 3 B
SPX3A1 (T)	CA 0 B
SPX3A1 (T)	DD 2 C
SPX3A1 (T)	FB 0 B
SPX3A1 (T)	GA 1 D
SPX3A1 (T)	NB 3 C
SPX3A2 (T)	AC 1 D
SPX3A2 (T)	AD 3 B
SPX3A2 (T)	FC 1 C
SPX3A2 (T)	GA 4 D
SPX3A8 ( )	BX 0 D
SPX3A10 ( )	BX 1 D
SPX3B (T)	AD 3 A
SPX3B (T)	BA 2 E
SPX3B (T)	BE 1 B
SPX3B (T)	BG 2 B
SPX3B (T)	BP 1 B
SPX3B (T)	EA 2 B
SPX3B2 (T)	AD 3 A
SPX3B2 (T)	BA 3 E
SPX3B2 (T)	DD 0 C
SPX3B3 (T)	AD 3 A
SPX3B3 (T)	BG 1 A
SPX3B4 (T)	BG 2 A
SPX3C (T)	AD 3 B
SPX3C (T)	BG 0 B
SPX3C (T)	GH 4 E
SPX3C (T)	GQ 1 D
SPX3H (T)	AD 3 A
SPX3H (T)	GD 4 E
SPX4A (T)	AD 3 D
SPX4A (T)	BE 1 B
SPX4A (T)	CI 2 D
SPX4A (T)	FB 0 D
SPX4A (T)	IC 2 D
SPX4A (T)	ID 1 D
SPX4A2 (T)	AD 4 D
SPX4A2 (T)	HA 0 C
SPX4A3 (T)	IC 1 D

SPLICE	PAGE
SPX4A3 (T)	ID 3 D
SPX4A5 (T)	BE 1 B
SPX4A6 (T)	BE 3 A
SPX4A17 (T)	AD 4 D
SPX4A17 (T)	AB 1 B
SPX4A17 (T)	GA 2 D
SPX4A17 (T)	NB 1 C
SPX4A18 (T)	CI 2 C
SPX4B (T)	AD 3 D
SPX4B (T)	GD 2 E
SPX4C (T)	AD 3 D
SPX4C (T)	GD 4 E
SPX4C (T)	GH 2 E
SPX4C (T)	KA 1 D
SPX4D (T)	AD 3 D
SPX4D (T)	XA 1 D
SPX4D (T)	XB 2 D
SPX71D1 (S)	CJ 4 B
SPXA1 (S)	AD 1 B
SPXF1A1 (S)	AD 1 C
SPXF1A1 (S)	CD 0 E
SPXF1A1 (S)	FB 0 E
SPXF1A1 (S)	HA 0 E
SPXF1A2 (S)	AD 1 C
SPXF1A2 (S)	FD 2 E
SPXF1A2 (S)	GA 4 D
SPXF1A2 (S)	GF 2 B
SPXF1A3 ( )	GF 2 D
SPXF1A11 (S)	FB 2 E
SPXF1A11 (S)	GF 1 E
SPXF1A11A2 (S)	GF 2 D
SPXF1A14 (S)	AD 0 C
SPXF1A14 (S)	FA 2 E
SPXF1A14 (S)	GF 2 E
SPXF1A15 (S)	CG 1 E
SPXF1A15 (S)	GF 2 D
SPXF1A16 ( )	BX 2 D
SPXF1A17 (S)	CG 1 D
SPXF1A24 ( )	FA 4 C
SPXF1C (S)	AD 1 C
SPXF1C1 (S)	AD 1 C
SPXF1C1 (S)	CA 2 C
SPXF1C2 (S)	AD 1 C
SPXF1C2 (S)	CA 2 C
SPXF1C2 (S)	CH 4 C
SPXN109J (S)	FD 2 D

Document title  
WIRING DIAGRAM TYPE OL

Document No

Issue

Volume

Page

Volvo Truck Corporation

Document type  
PRODUCT SCHEMATIC

24403869

01

2 (2)

13 (63)



0

1

2

3

4

### BILL OF MATERIALS INDEX (VOL 2)

NAME	PAGE
COMPONENTS	2
CABLES	6

NAME	PAGE
INLINES	8
FUSES AND CIRCUIT BREAKERS	10

NAME	PAGE
RELAYS	11
SPLICES	12

NAME	PAGE
REFERENCES	14

A

A

B

B

C

C

D

D

E

E

Volvo Truck Corporation

Document title WIRING DIAGRAM TYPE OL
--

Document type PRODUCT SCHEMATIC
------------------------------------

Document No
-------------

24403869

Issue
-------

01

Volume
--------

2 (2)

Page
------

1 (63)

0

1

2

3

4