

Engineering Release Notice (ERN)	Location	Change Description	A = Added D = Deleted	W = Was	Document Release Status RELEASED
D-16275-50		SEE DCN			Date Modification Count

WIRING DIAGRAM INDEX, 12V

NAME	DESCRIPTION	Page	NAME	DESCRIPTION	Page
AA	POWER DISTRIBUTION 1/2	2	FA	AIR DRYER / HEATED DRAIN	26
AB	POWER DISTRIBUTION 2/2	3	FB	CHASSIS SOLENOIDS	27
AC-O	KEY SW., START & CHARGING	4	FC-O	VICKERS PUMP (PACKER & PLOW) WORKBRAKE SOLENIOD, & HOUR METER	28
AD	GROUNDING	5	FD	PARKER PTO	29
BA	VEHICLE ECU 1/4	6	GA-O	LIGHTING CONTROLS	30
BB	VEHICLE ECU 2/4	7	GD-O	LIGHTING - FORWARD / SIGNAL WITH PLOW LAMP PROVISION	31
BC	VEHICLE ECU 3/4	8	GF	LIGHTING - TAIL LAMP	32
BD	VEHICLE ECU 4/4	9	GG	TRAILER LIGHTING CONTROL	33
BE-O	INSTRUMENT CLUSTER 1/3	10	GH	LH / RH LIGHTING CONTROLS INTERIOR LIGHTING	34
BF	INSTRUMENT CLUSTER 2/3	11	GP	WIPER / WASHER	35
BG	INSTRUMENT CLUSTER 3/3	12	GQ	HORN WIRING	36
BH	ALLISON BODY BUILDER INTERFACE	13	HA	CLIMATE CONTROL US10 STYLE ROOF A/C	37
BJ	BODY LINK II CONSTRUCTION BODY BUILDER CIRCUITS	14	IC	MIRROR CONTROL 1/2	38
BM	BODY LINK II REFUSE BODYBUILDER CIRCUITS	15	ID	MIRROR CINTROL 2/2	39
CA-O	ENGINE INTERFACE MP7	16	KA	AUDIO & VISUAL SYSTEM	40
CB	DPF CONTROL SYSTEM	17	KB	AUDIO SYSTEMS	41
CC	ENGINE HEATER	18	KC	POWER OUTLET CONNECTIONS	42
CD	AUXILLARY COOLING FANS (NOT USED)	19	NA-O	SPARE CONNECTORS & FEEDS	43
CF	UREA DOSING SYSTEM 1/2	20	NB-O	JUNCTION POSTS	44
CH	UREA DOSING SYSTEM 2/2	21	XA-O	DATA LINK / DIAGNOSTICS	45
DC	TRANSMISSION CNTR:4 GENERATION 1/3	22			
DD	TRANSMISSION CNTR:4 GENERATION 2/3	23			
EC-O	JUNCTION POSTS -DPF	24			
ED	ABS8 BENDIX	25			

The copying, distribution and utilization of this document as well as the communication of its contents to others without expressed authorization is prohibited. Offenders will be held liable for payment of damages. All rights reserved in the event of the grant of a patent, utility model or ornamental design registration.

Document Title
**WIRING DIAGRAM
 OM (MRU) 2014 - SCHEMATIC
 N. Y. CITY SANITATION**

MACK

Mack Trucks, Inc.

Document Type
TECHNICAL REGULATION

Owner Domain: Document Prefix

Document No	Issue Index	Volume No	Page No
22525262	02	01	1(45)

POWER DISTRIBUTION 1/2

WIRING DIAGRAM: AA

BATT
IGN
EMS
ILLUM

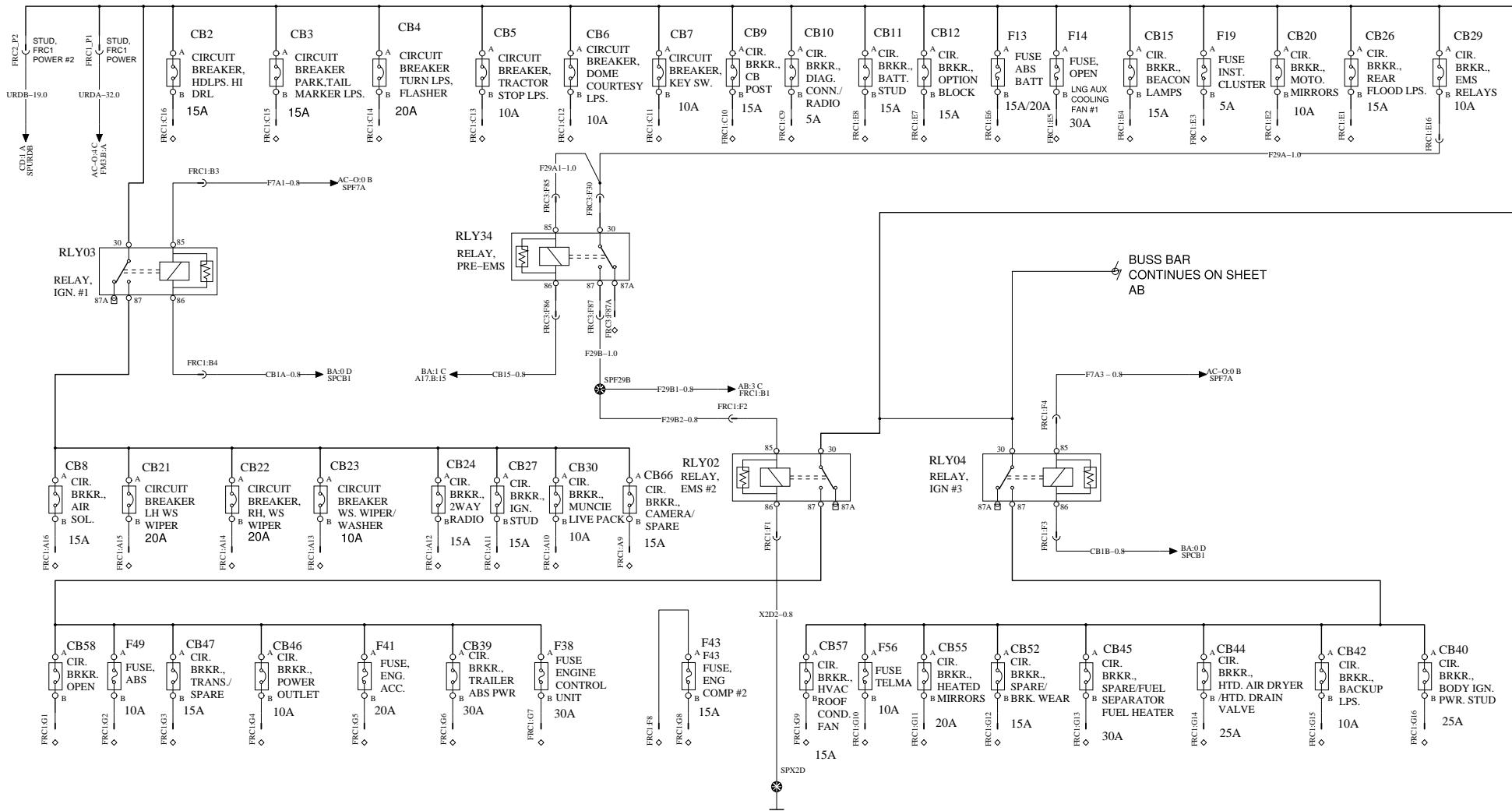

MACK

Mack Trucks Inc.

Document title
WIRING DIAGRAM
Document type
PRODUCT SCHEMATIC

Drawing No.
22525262

Revision
02

Page
2 (45)

POWER DISTRIBUTION 2/2

WIRING DIAGRAM: AB

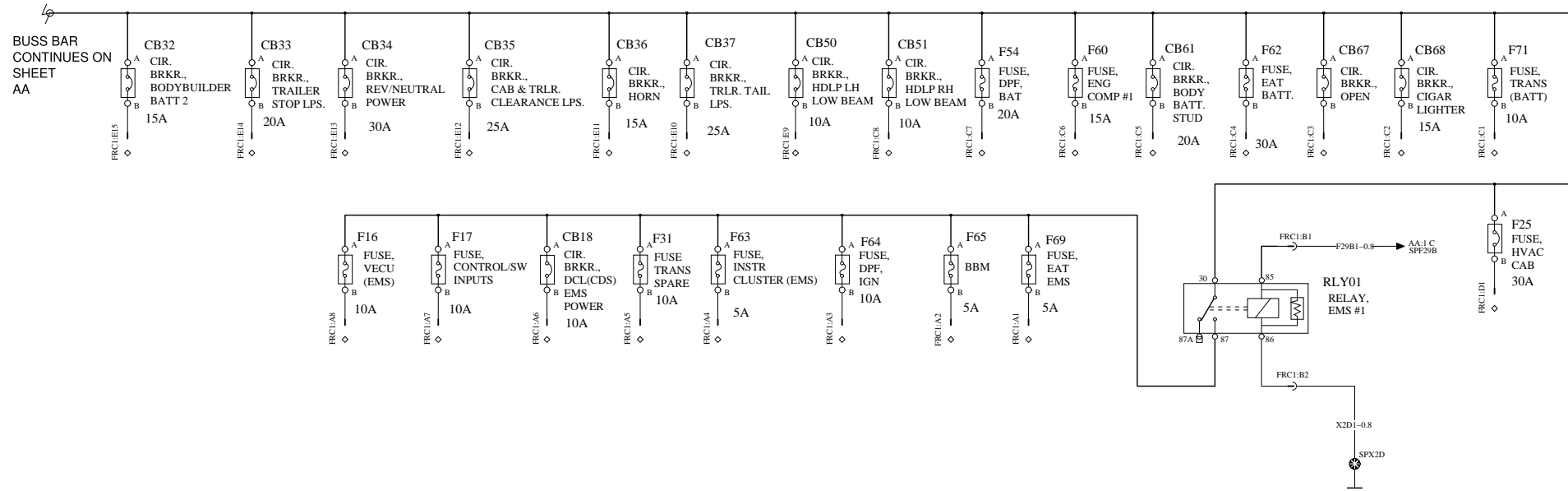
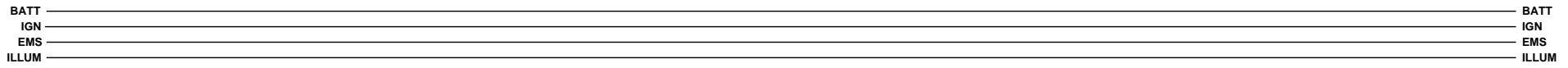

MACK

Mack Trucks Inc.

Document title
WIRING DIAGRAM

Document type
PRODUCT SCHEMATIC

Drawing No.

22525262

Revision

02

Page

3 (45)

WIRING DIAGRAM: AC - O

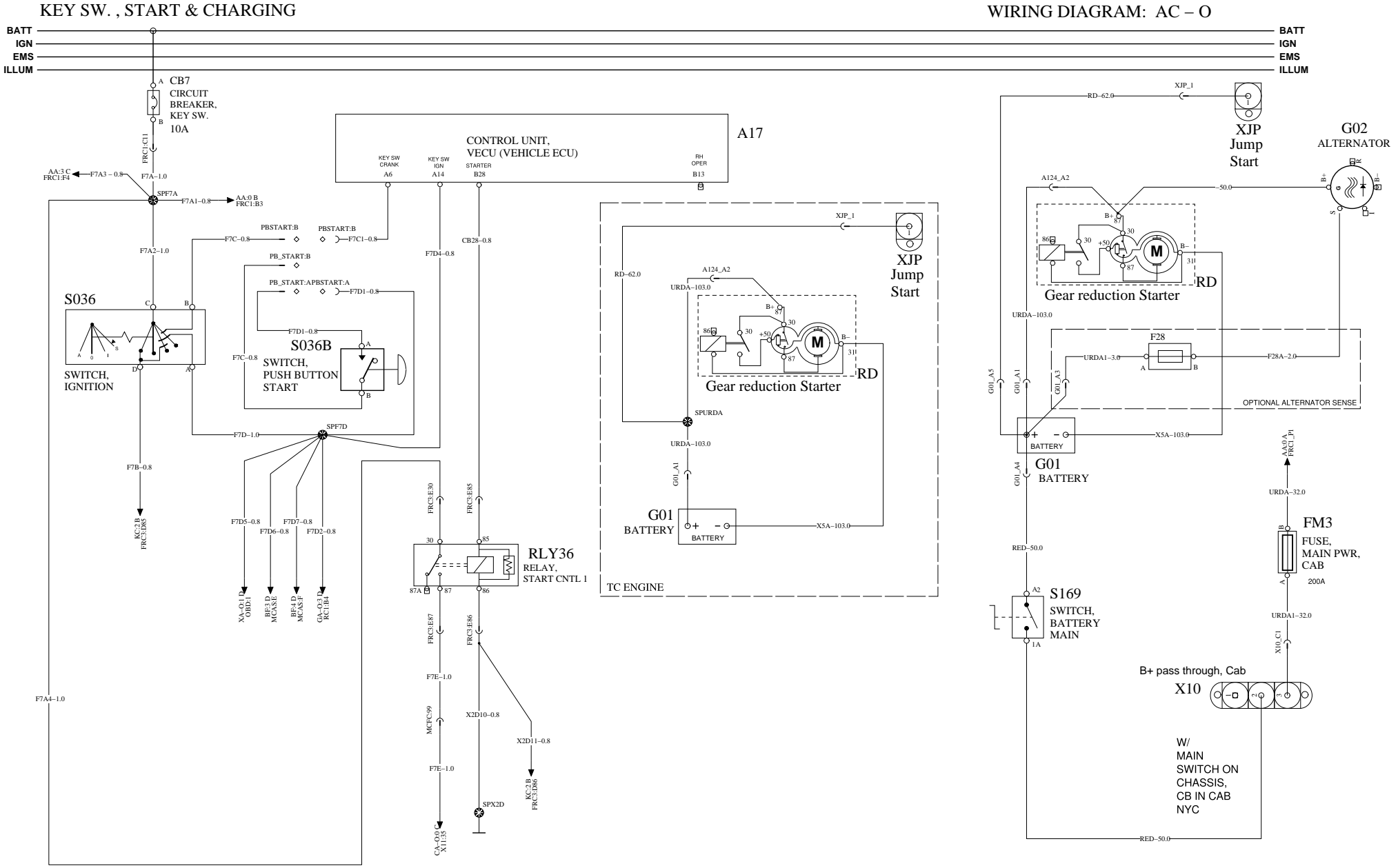

WIRING DIAGRAM: BA

VEHICLE ECU 1/4

BATT
IGN
EMS
ILLUM

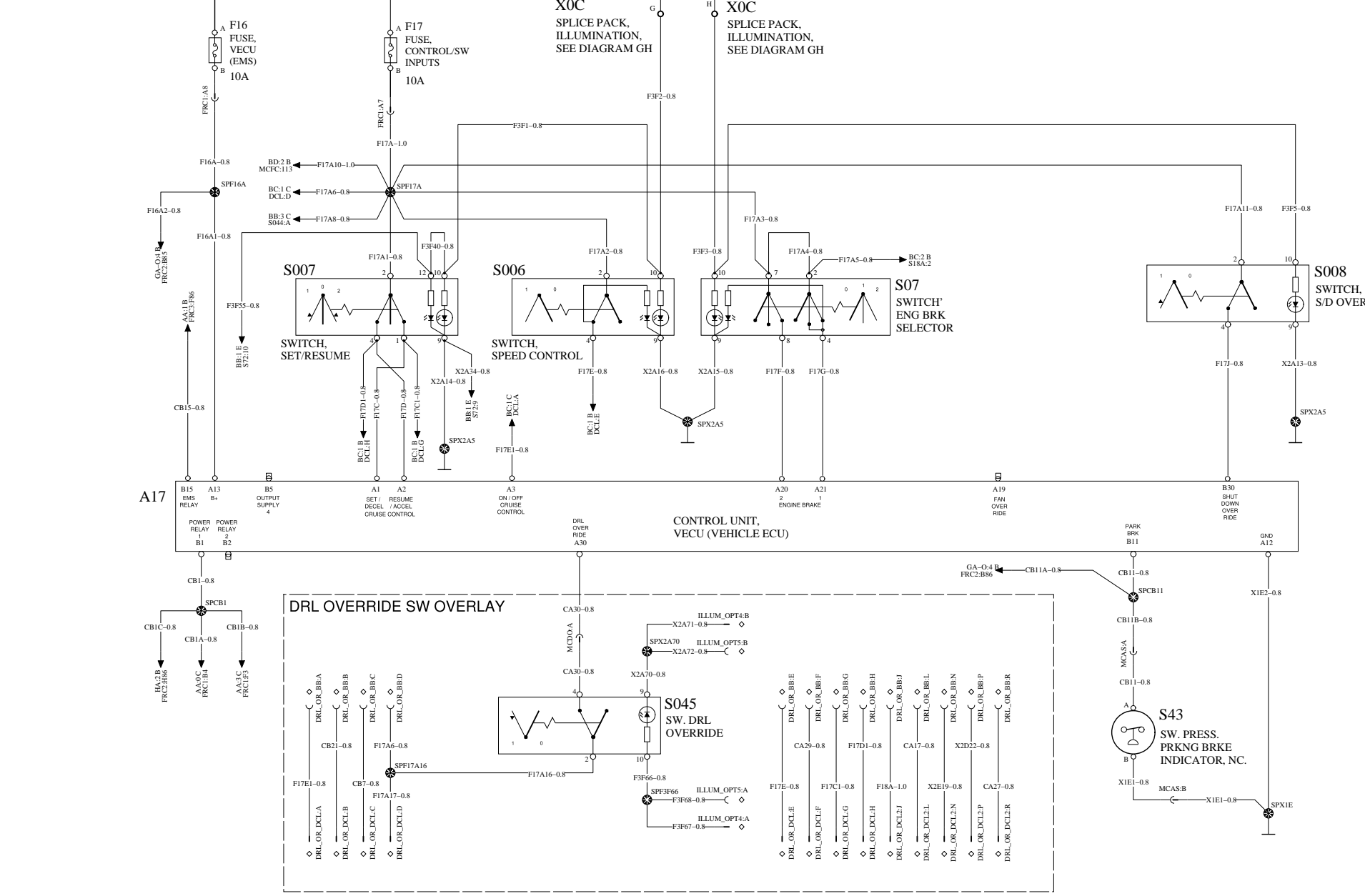

MACK

Mack Trucks Inc.

Document title
WIRING DIAGRAM

Document type
PRODUCT SCHEMATIC

Drawing No. 22525262	Revision 02	Page 6 (45)
--------------------------------	-----------------------	-----------------------

VEHICLE ECU 3/4 - DCL CONNECTOR

WIRING DIAGRAM: BC

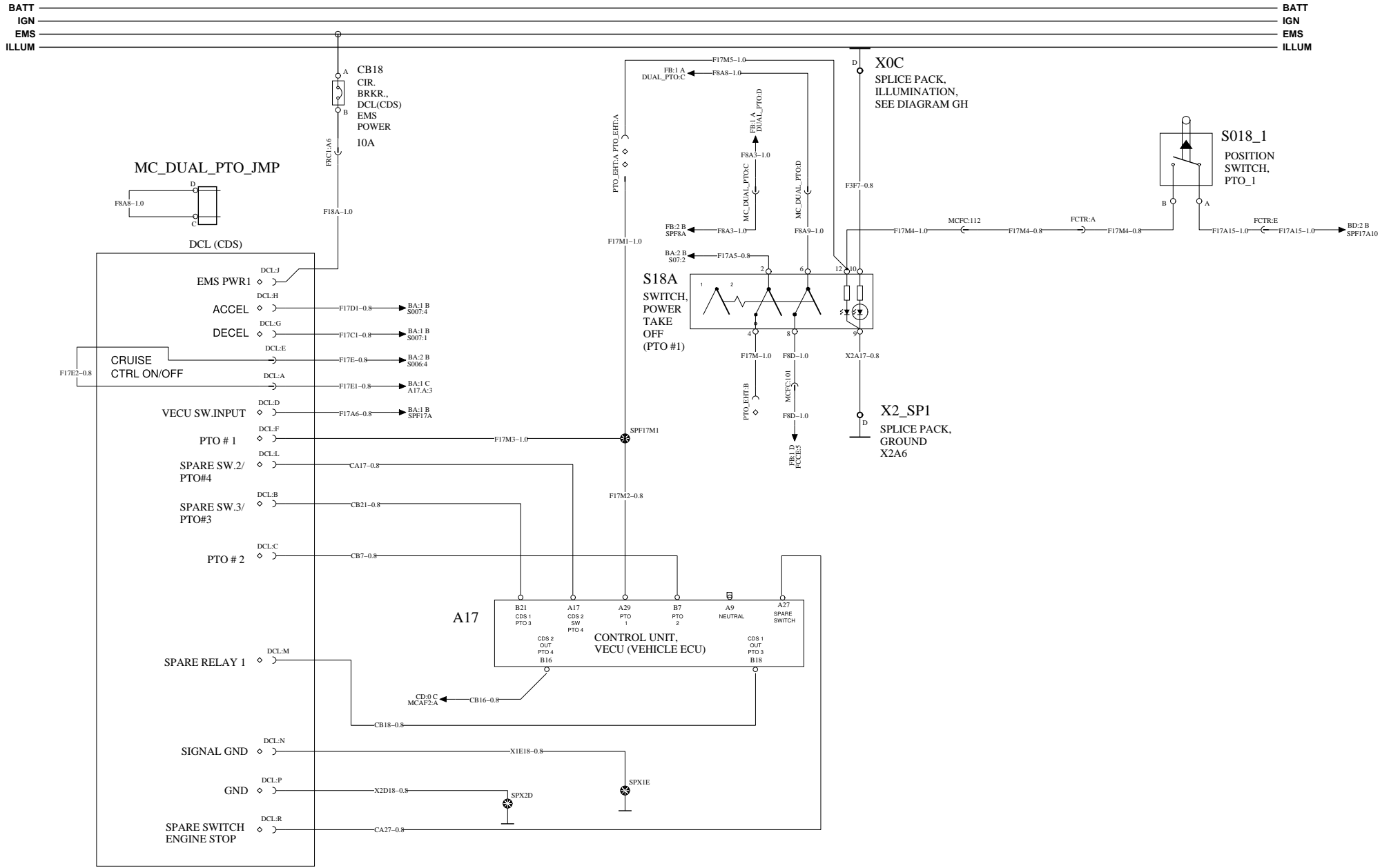

MACK

Mack Trucks Inc.

Document title
WIRING DIAGRAM

Document type
PRODUCT SCHEMATIC

Drawing No. 22525262	Revision 02	Page 8 (45)
--------------------------------	-----------------------	-----------------------

BATT
 IGN
 EMS
 ILLUM

BATT
 IGN
 EMS
 ILLUM

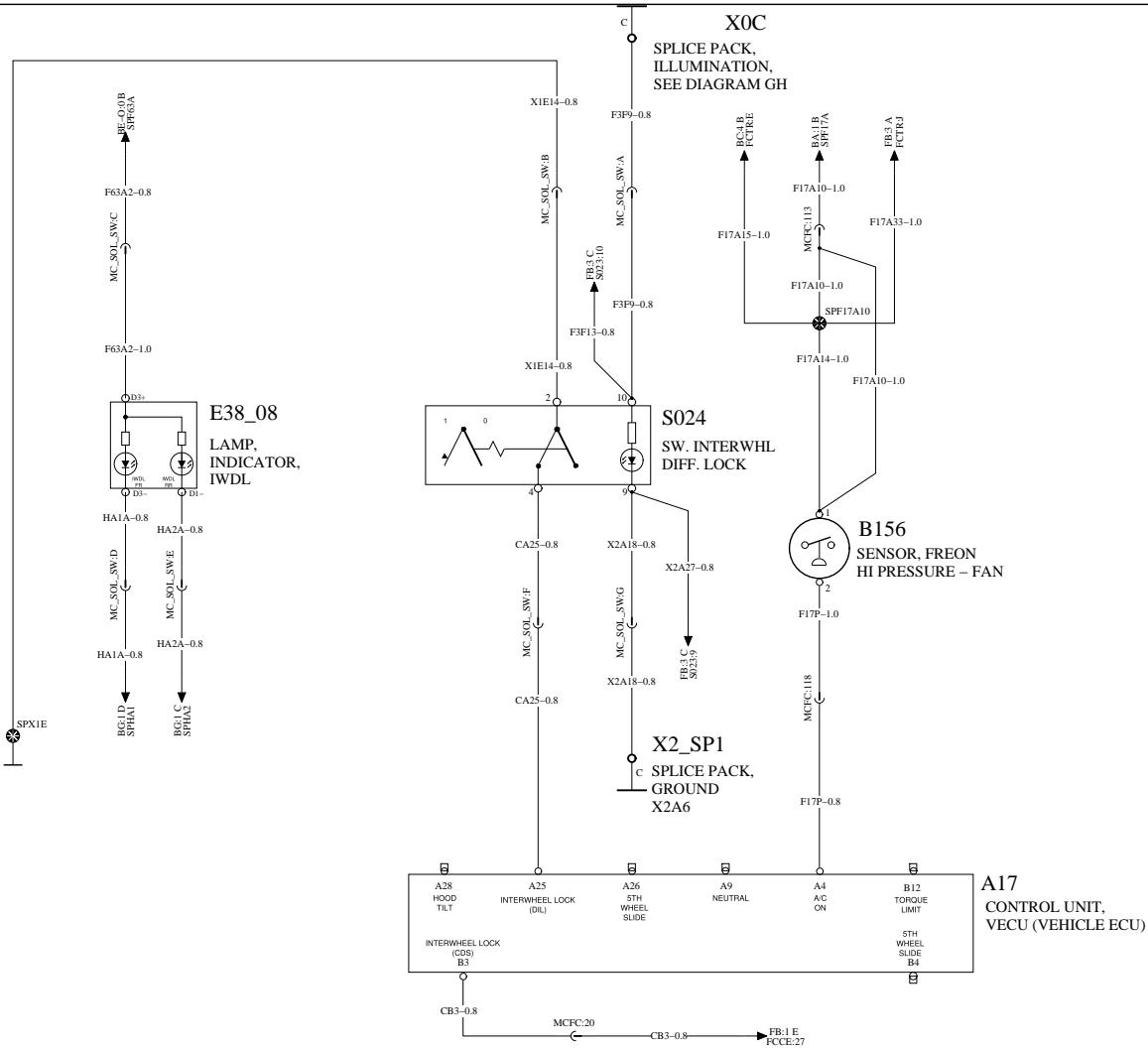

INSTRUMENT CLUSTER 2/3

WIRING DIAGRAM: BF

BATT
IGN
EMS
ILLUM

BATT
IGN
EMS
ILLUM

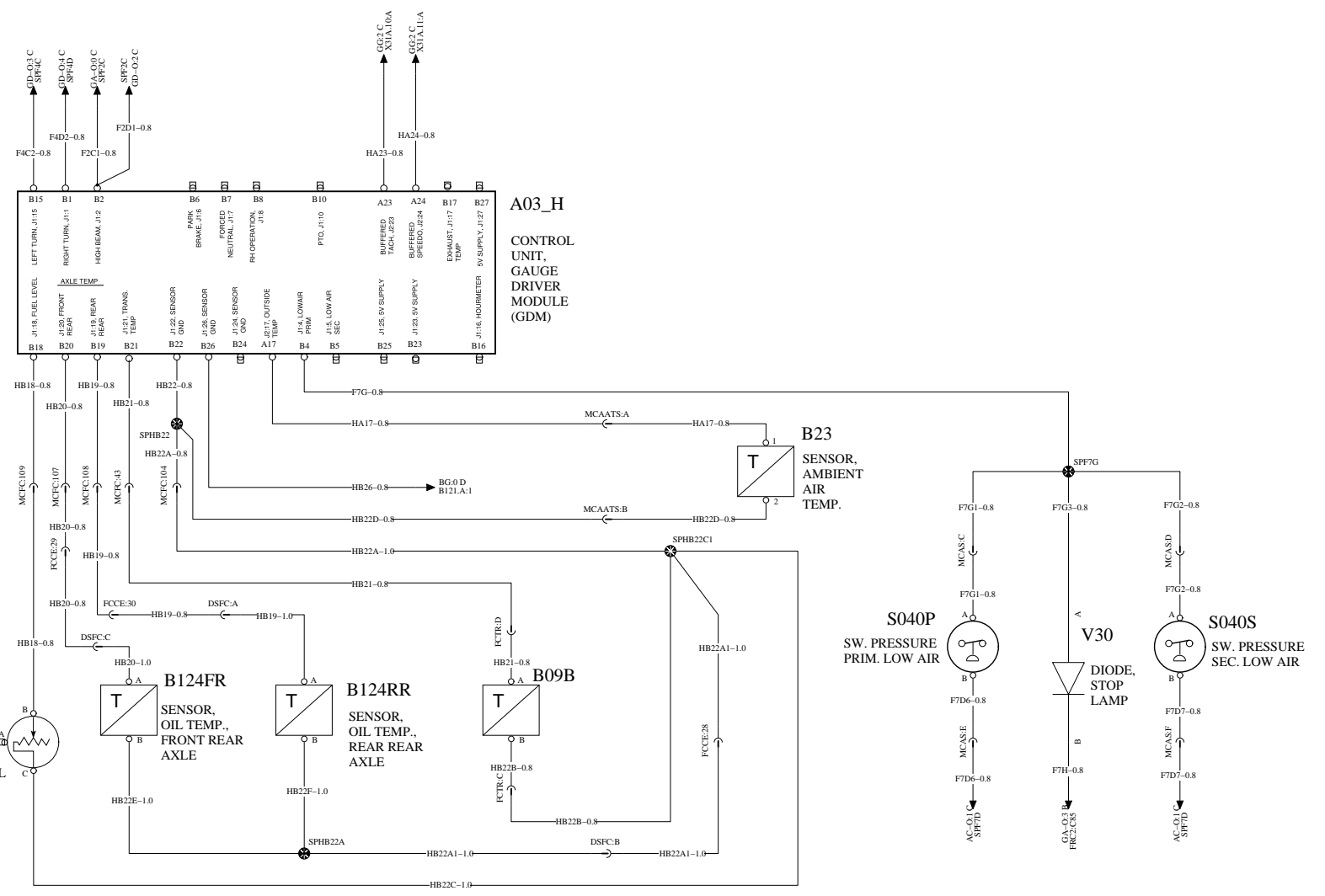

0

1

2

3

4

ALLISON BODY BUILDER INTERFACE

WIRING DIAGRAM: BH

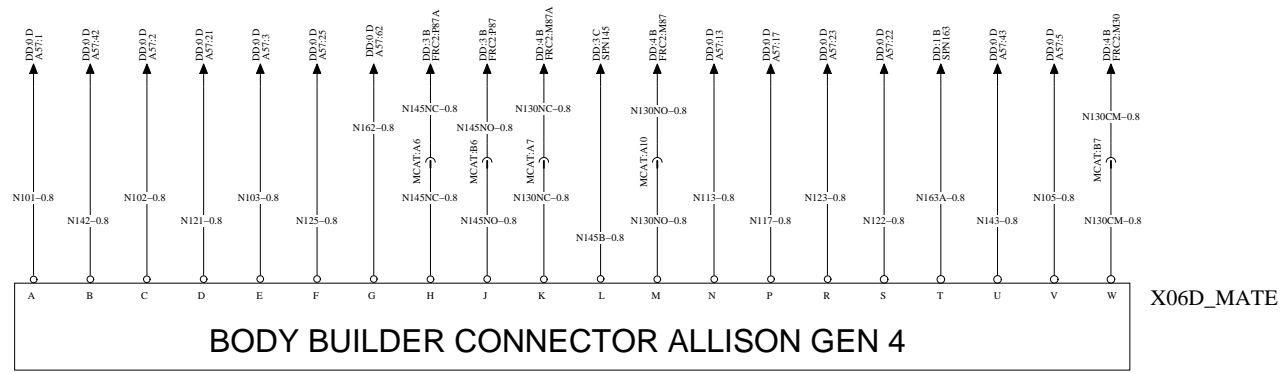
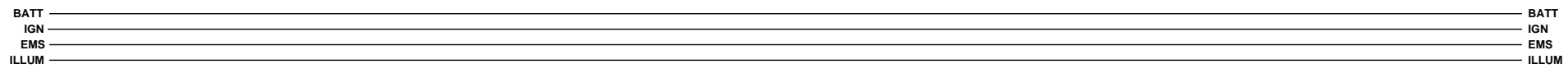

MACK

Mack Trucks Inc.

Document title WIRING DIAGRAM
Document type PRODUCT SCHEMATIC

Drawing No. 22525262

Revision 02

Page 13 (45)

0

1

2

3

4

BODY LINK II CONSTRUCTION BODYBUILDER CIRCUITS

BJ

BATT _____ BATT
 IGN _____ IGN
 EMS _____ EMS
 ILLUM _____ ILLUM

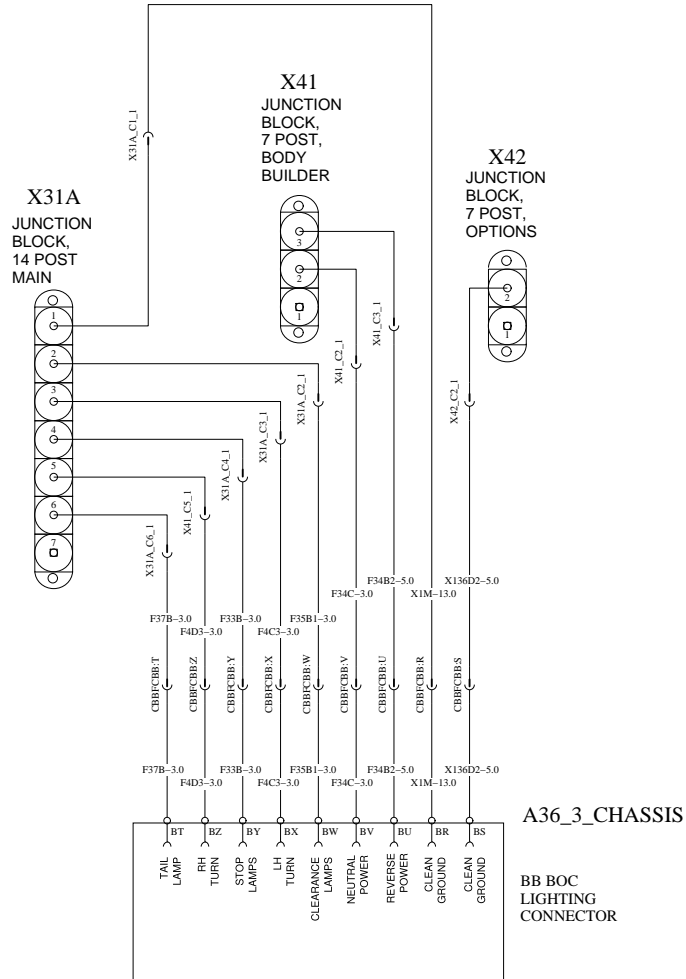

MACK

Mack Trucks Inc.

Document title
 WIRING DIAGRAM

Document type
 PRODUCT SCHEMATIC

Drawing No.

22525262

Revision

02

Page

14 (45)

BODY LINK II REFUSE BODYBUILDER CIRCUITS

WIRING DIAGRAM: BM

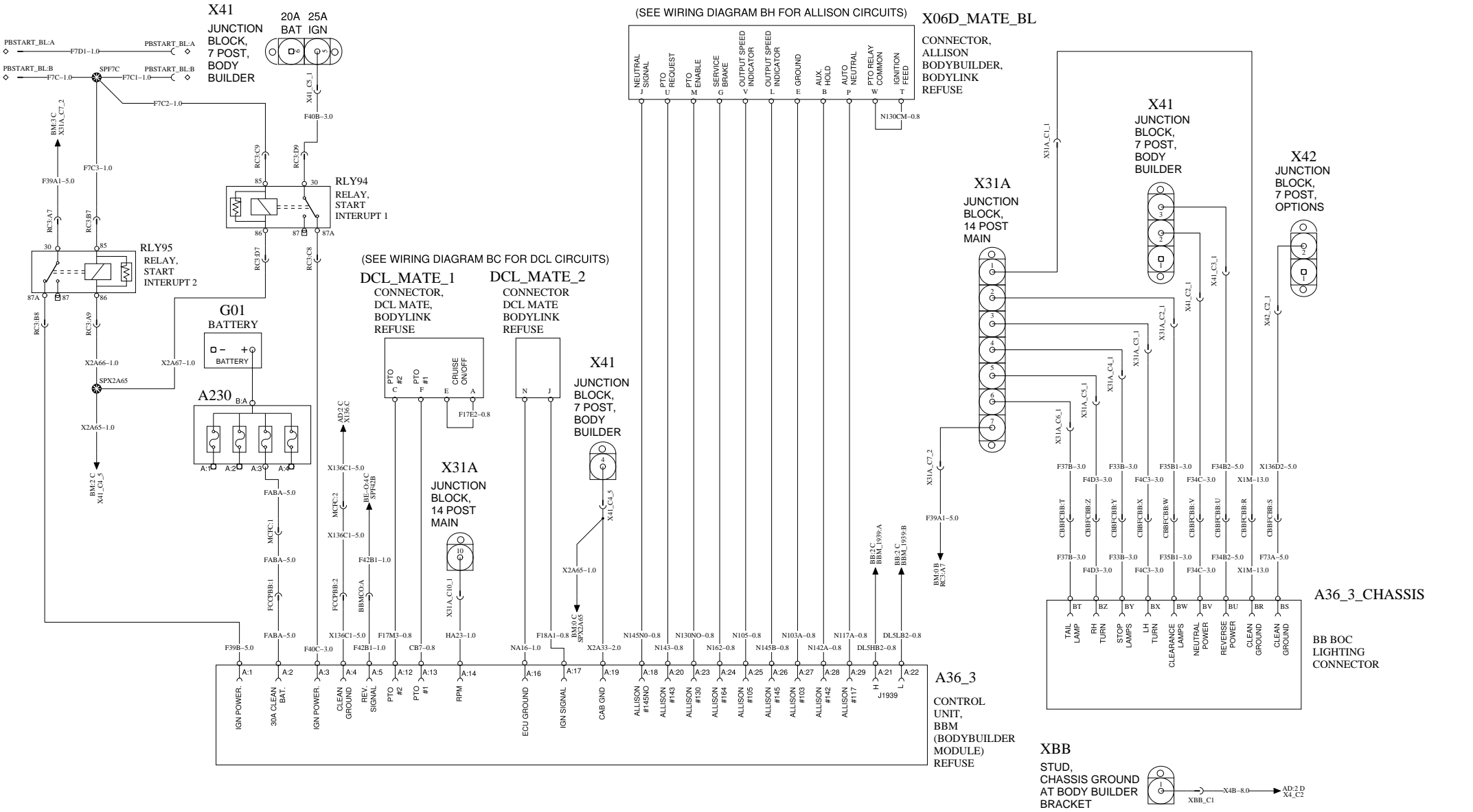
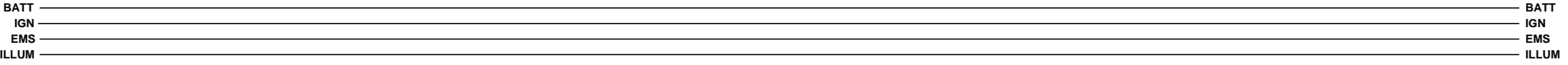

MACK

Mack Trucks Inc.

Document title
WIRING DIAGRAM

Document type
PRODUCT SCHEMATIC

Drawing No.

22525262

Revision

02

Page

15 (45)

ENGINE INTERFACE MP7 & MP8

WIRING DIAGRAM: CA - O

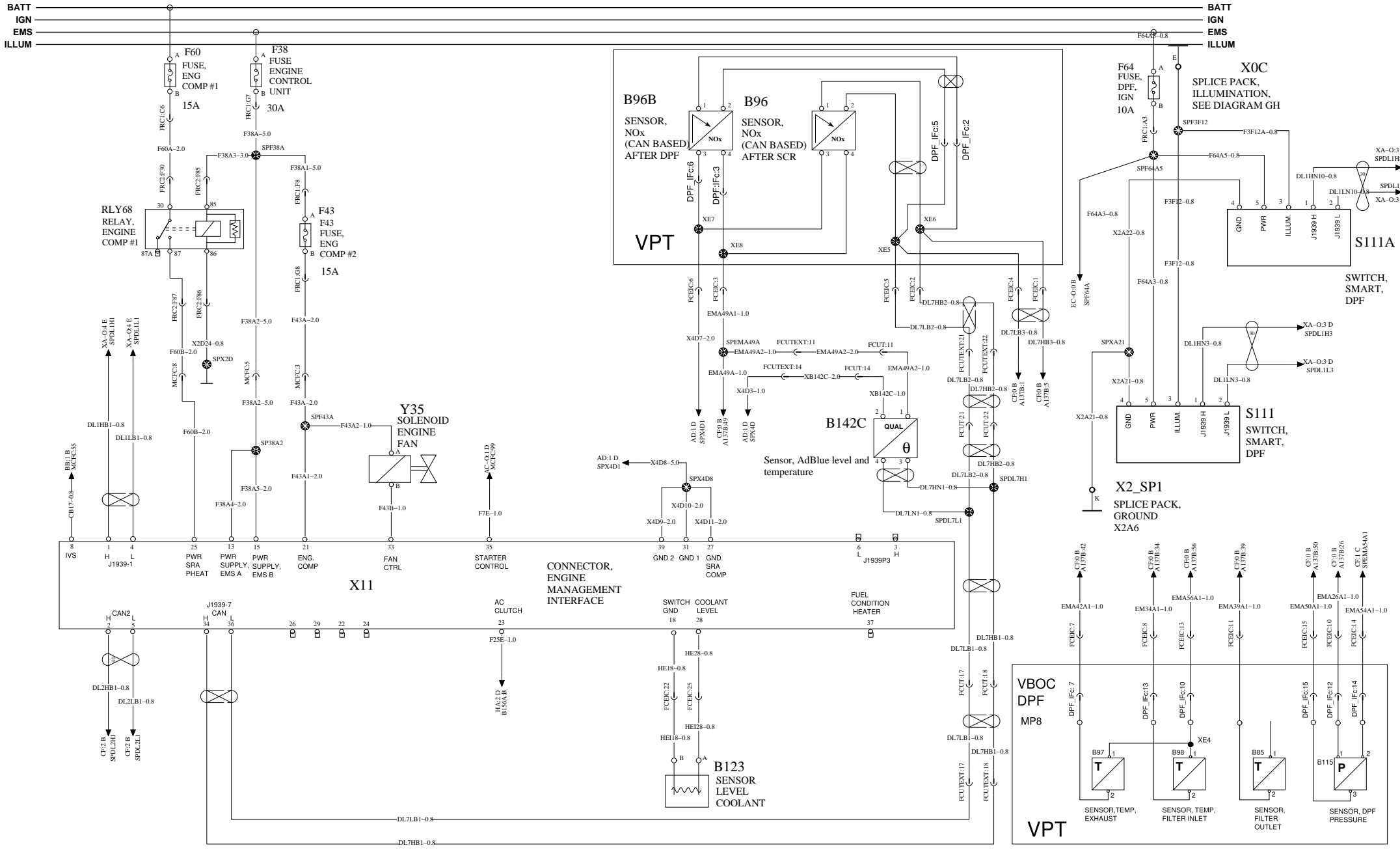

MACK

Mack Trucks Inc.

Document title
WIRING DIAGRAM
Document type
PRODUCT SCHEMATIC

Drawing No. 22525262	Revision 02	Page 16 (45)
--------------------------------	-----------------------	------------------------

DPF CONTROL SYSTEM (WITH THERMAL REDUCTION UNIT)

WIRING DIAGRAM: CB

BATT
IGN
EMS
ILLUM

BATT
IGN
EMS
ILLUM

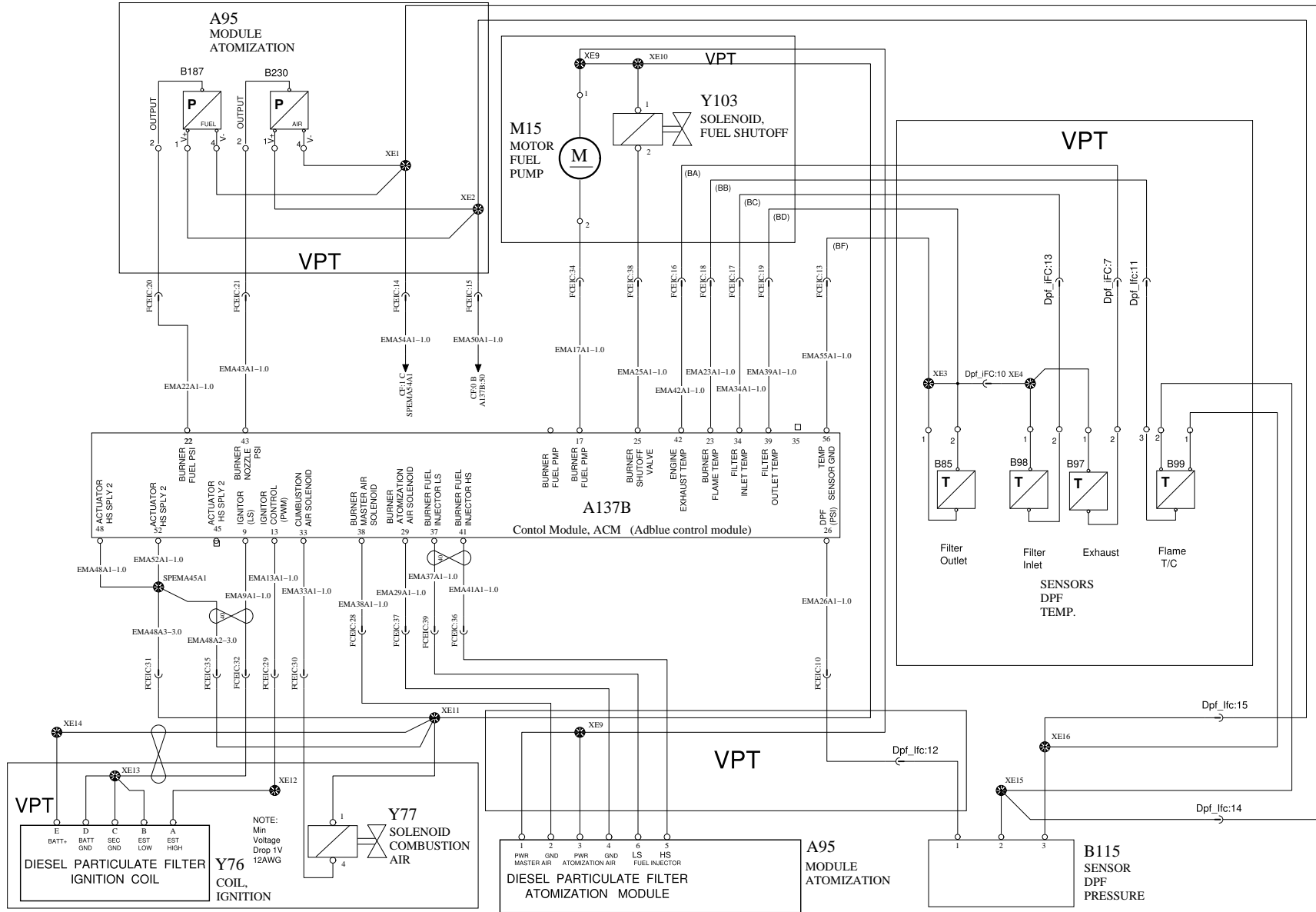

MACK

Mack Trucks Inc.

Document title
WIRING DIAGRAM
Document type
PRODUCT SCHEMATIC

Drawing No.
22525262

Revision
02

Page
17 (45)

0

1

2

3

4

ENGINE/FUEL HEATER

WIRING DIAGRAM: CC

BATT _____ BATT
 IGN _____ IGN
 EMS _____ EMS
 ILLUM _____ ILLUM

A

A

B

B

C

C

D

D

E

E

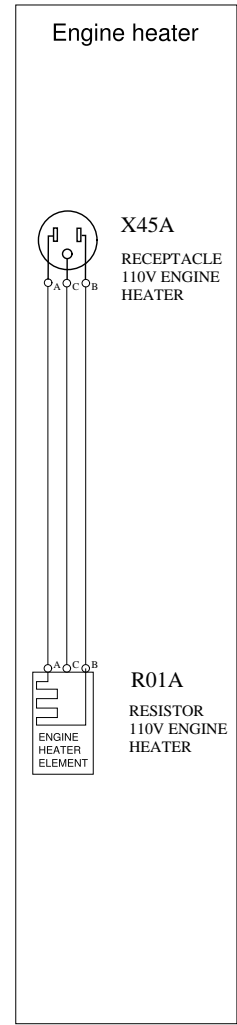
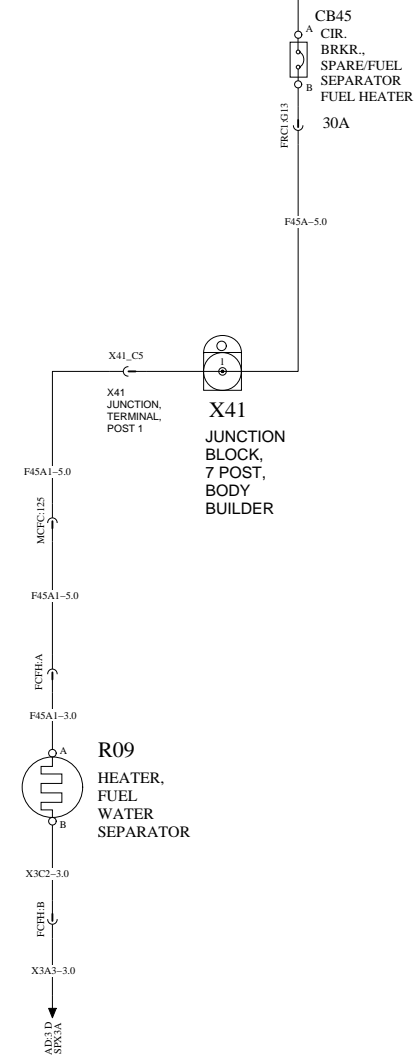
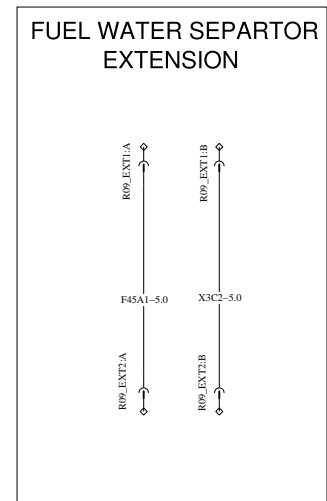

MACK

Mack Trucks Inc.

Document title
WIRING DIAGRAM

Document type
PRODUCT SCHEMATIC

Drawing No.
22525262

Revision
02

Page
18 (45)

0

1

2

3

4

0

1

2

3

4

AUXILIARY COOLING FANS

WIRING DIAGRAM: CD

BATT _____ BATT
 IGN _____ IGN
 EMS _____ EMS
 ILLUM _____ ILLUM

A

A

B

B

C

C

D

D

E

E

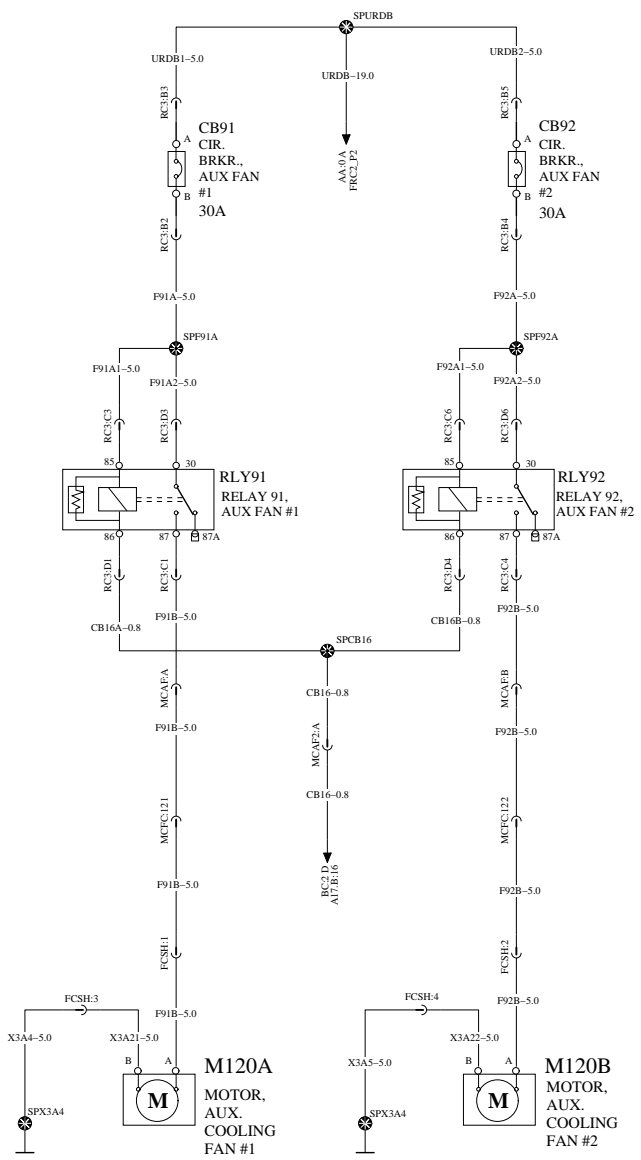

MACK

Mack Trucks Inc.

Document title WIRING DIAGRAM	Drawing No. 22525262	Revision 02	Page 19 (45)
Document type PRODUCT SCHEMATIC			

0

1

2

3

4

UREA DOSING SYSTEM 1/2

WIRING DIAGRAM: CF

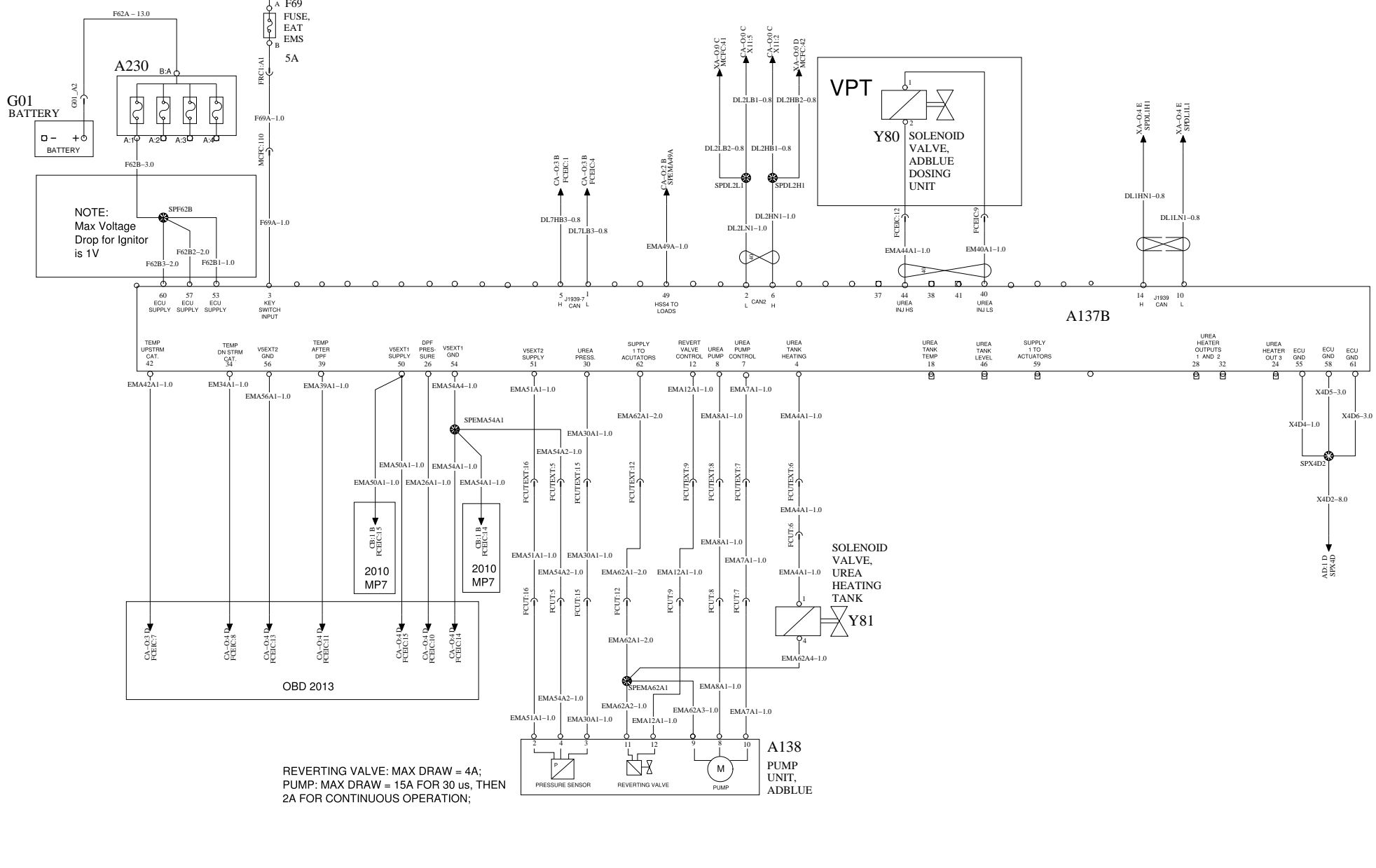
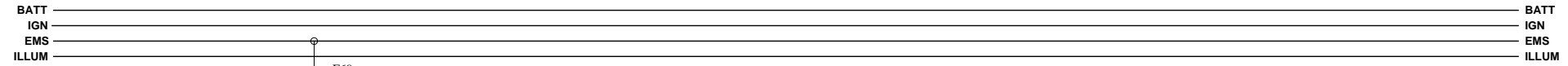

BATT
IGN
EMS
ILLUM

BATT
IGN
EMS
ILLUM

A137B

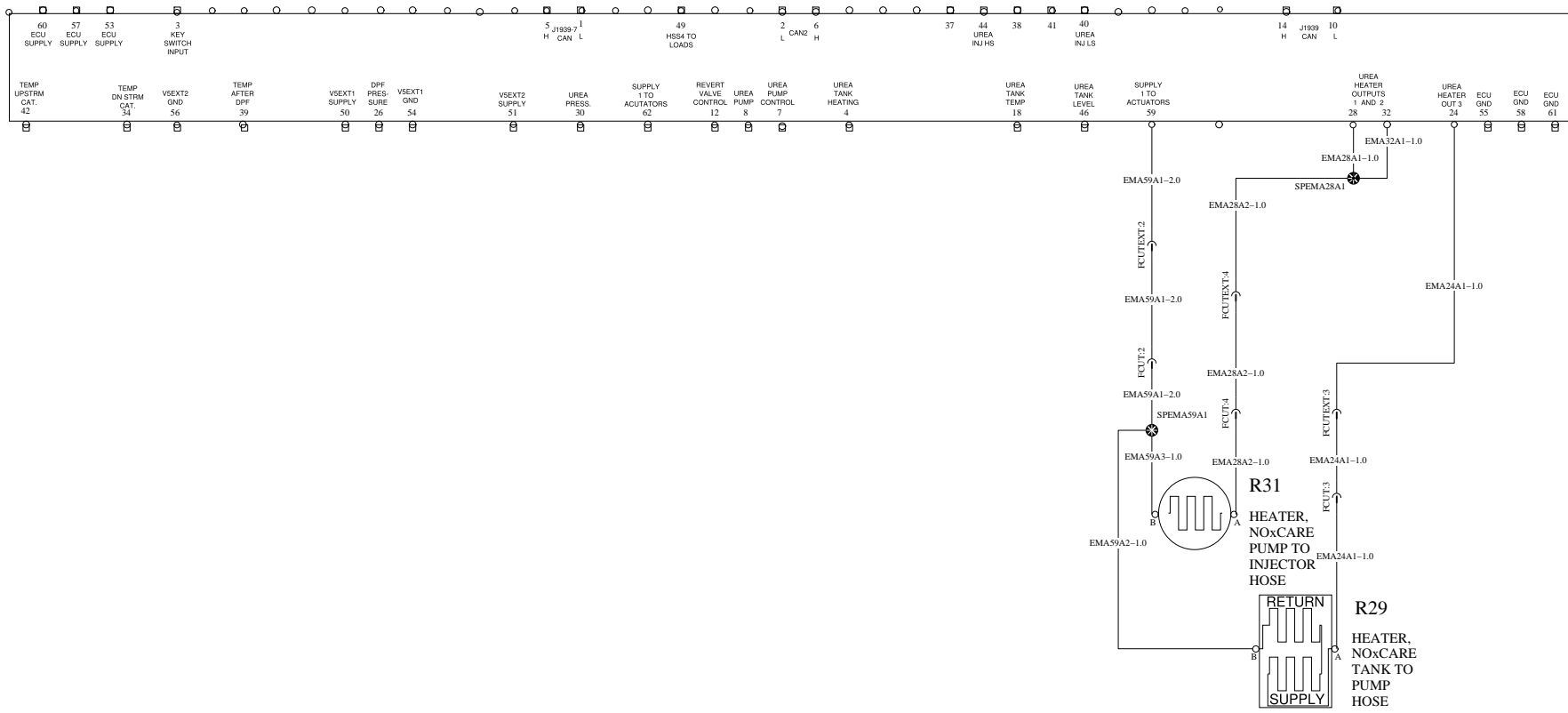

BATT
 IGN
 EMS
 ILLUM

BATT
 IGN
 EMS
 ILLUM

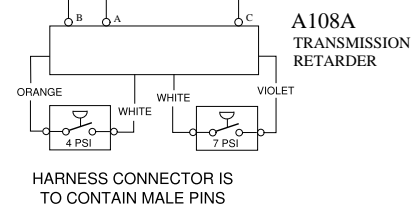
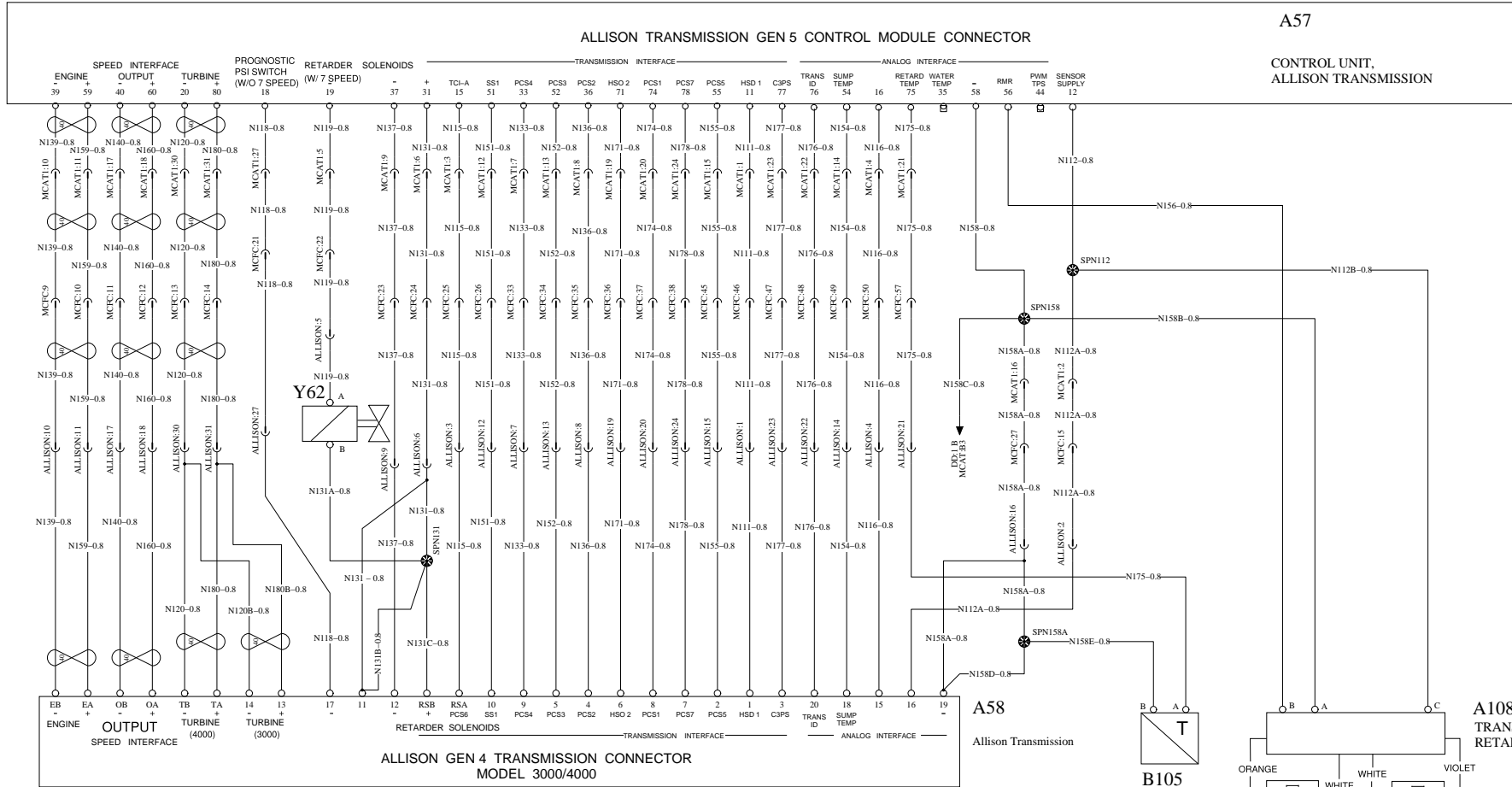

HARNES CONNECTOR IS TO CONTAIN MALE PINS

TRANSMISSION CONTROL 4th GENERATION 2/3

WIRING DIAGRAM: DD

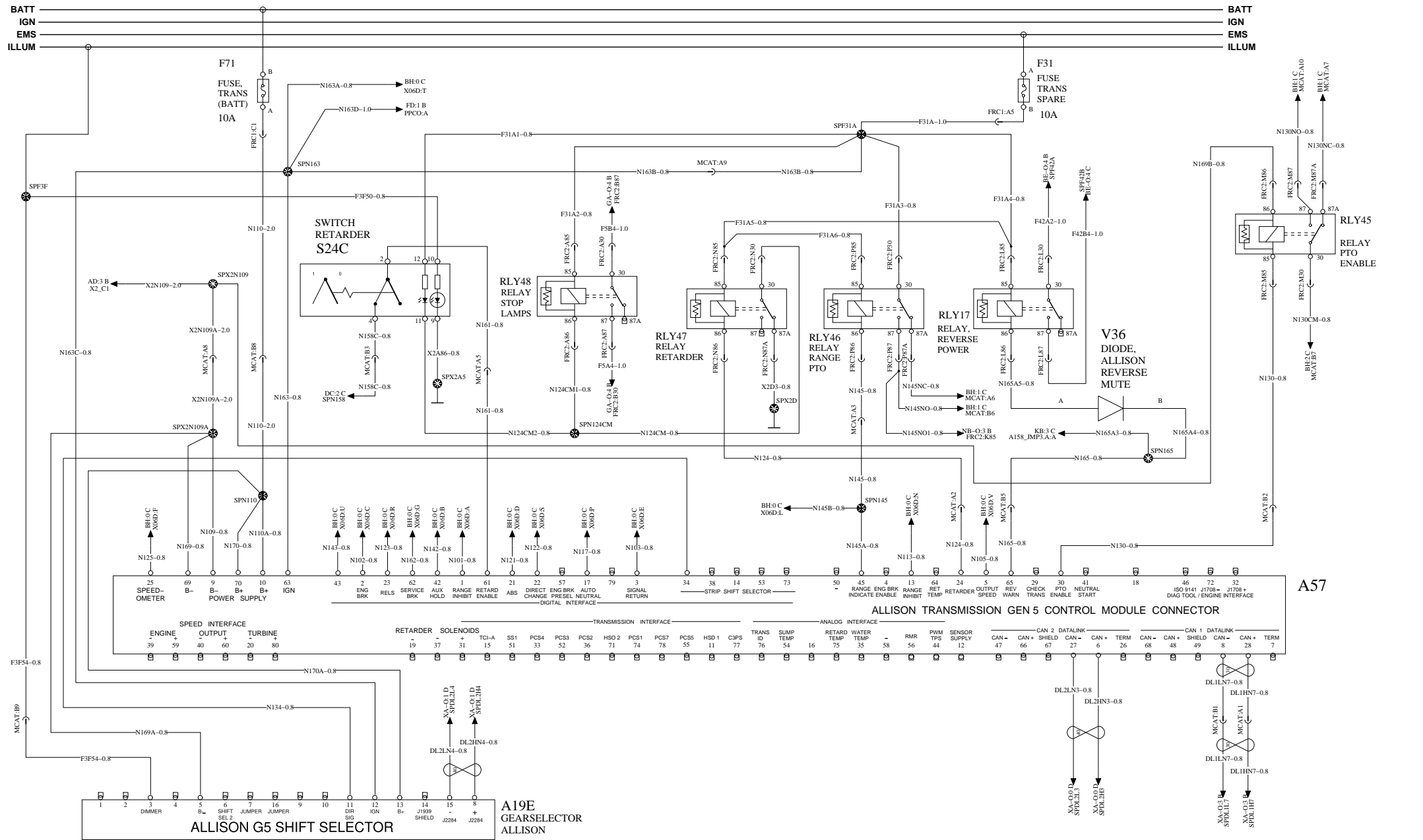

ABS8 BENDIX

: ED

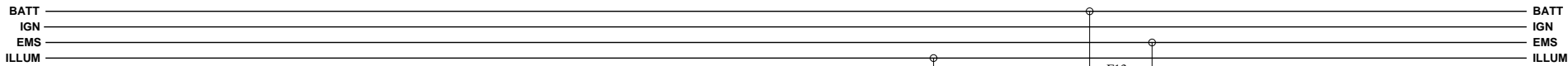

B15
SENSOR,
WHEEL SPD
LH RR RR AXLE

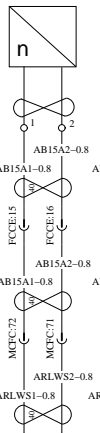

Y13
SOL. VALVE,
ABS LH RR

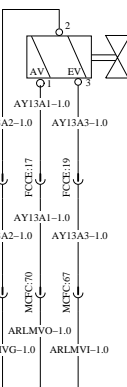

Y14
SOL. VALVE,
ABS RH RR

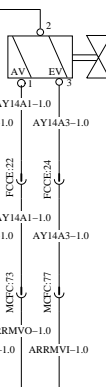

B16
SENSOR,
WHEEL SPD
RH RR RR AXLE

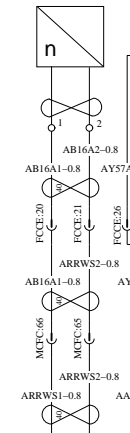

Y57
SOL. VALVE,
ATC

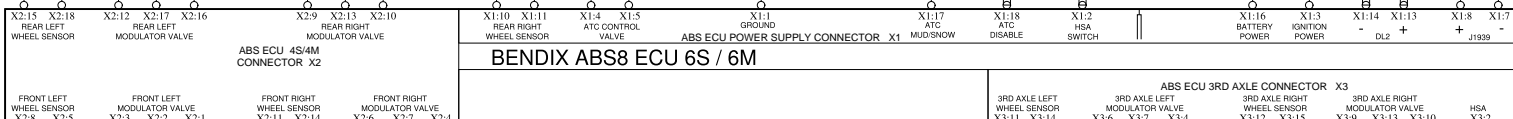
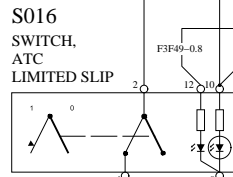
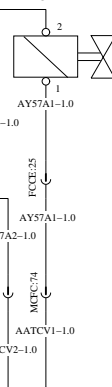

A12
Control unit, ABS
(Anti-lock Brake System)

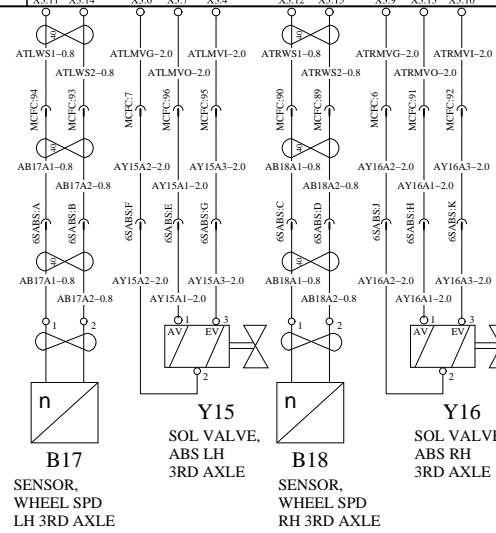

B13
SENSOR,
WHEEL SPD
LH FRT AXLE



Y11
SOL. VALVE,
ABS LH FRT



B14
SENSOR,
WHEEL SPD
RH FRT AXLE



Y12
SOL. VALVE,
ABS RH FRT



MACK

Mack Trucks Inc.

Document title WIRING DIAGRAM	Document type PRODUCT SCHEMATIC
----------------------------------	------------------------------------

Drawing No. 22525262	Revision 02	Page 25 (45)
--------------------------------	-----------------------	------------------------

0

1

2

3

4

AIR DRYER /HEATED DRAIN

WIRING DIAGRAM: FA

BATT _____ BATT
 IGN _____ IGN
 EMS _____ EMS
 ILLUM _____ ILLUM

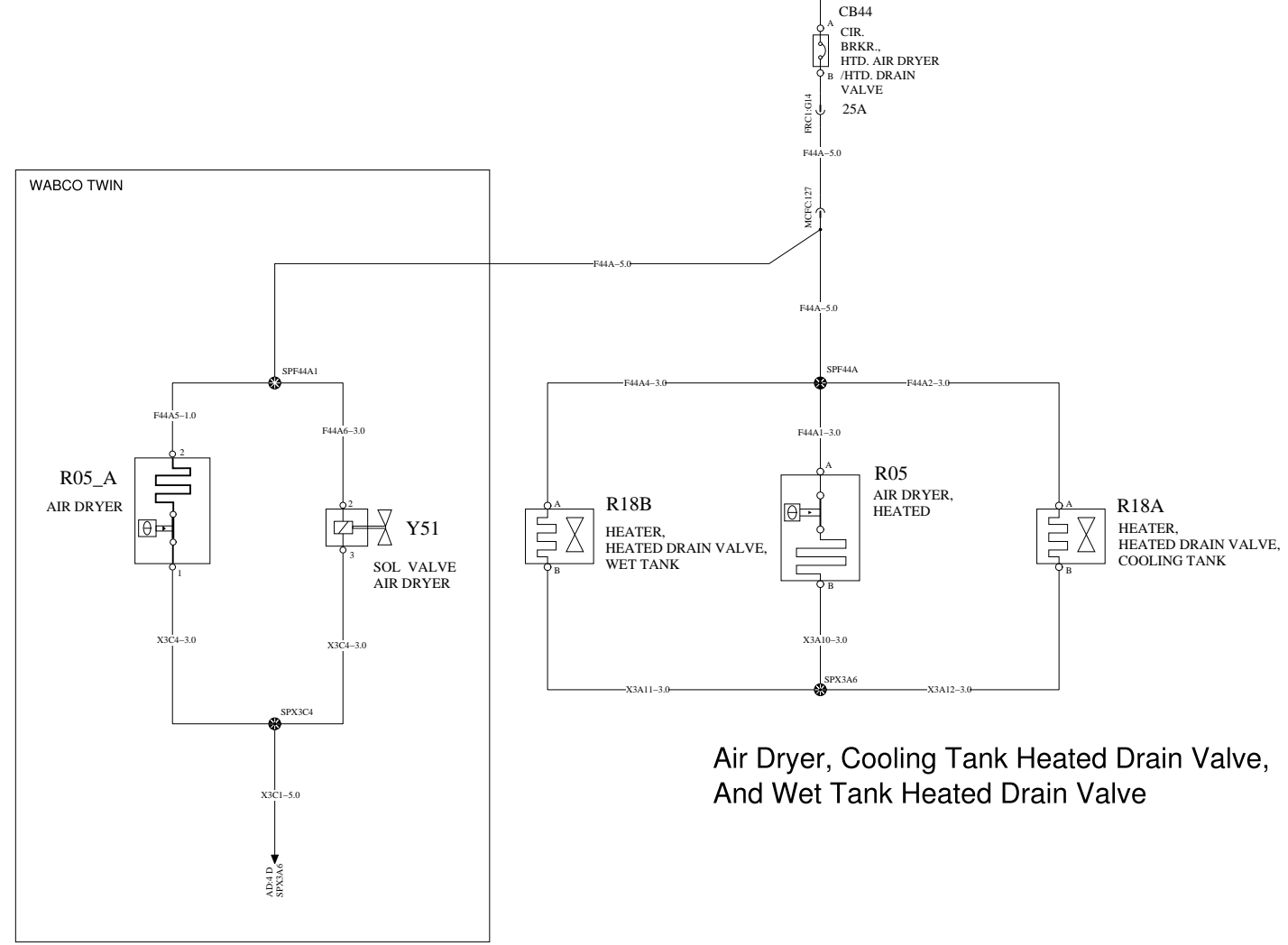

Air Dryer, Cooling Tank Heated Drain Valve, And Wet Tank Heated Drain Valve

MACK

Mack Trucks Inc.

Document title WIRING DIAGRAM
Document type PRODUCT SCHEMATIC

Drawing No. 22525262	Revision 02	Page 26 (45)
-------------------------	----------------	-----------------

0

1

2

3

4

CHASSIS SOLENOIDS

WIRING DIAGRAM: FB

BATT
IGN
EMS
ILLUM

BATT
IGN
EMS
ILLUM

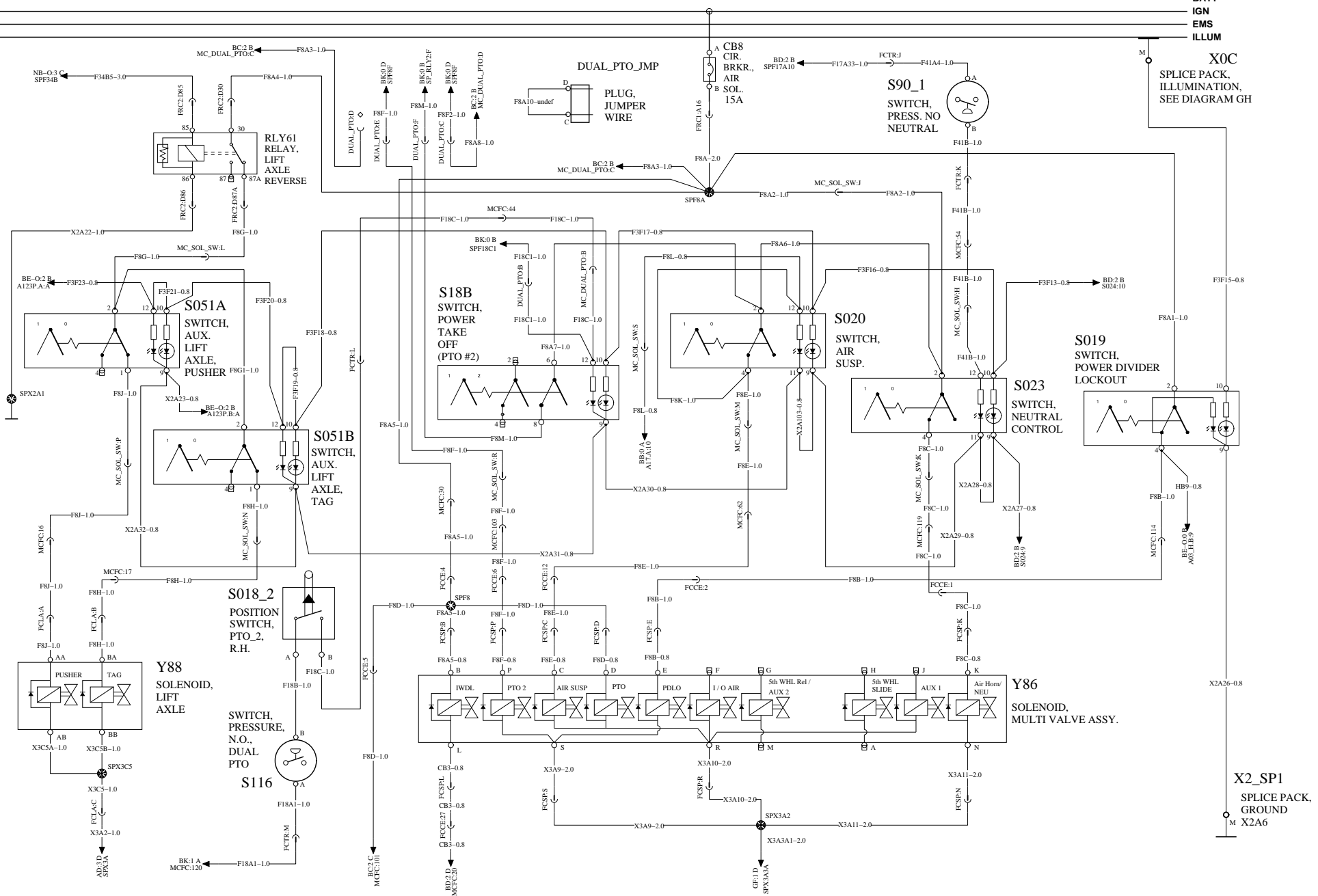

MACK

Mack Trucks Inc.

Document title WIRING DIAGRAM
Document type PRODUCT SCHEMATIC

Drawing No. 22525262	Revision 02	Page 27 (45)
-------------------------	----------------	-----------------

PARKER PTO

WIRING DIAGRAM: FD

BATT	_____	BATT
IGN	_____	IGN
EMS	_____	EMS
ILLUM	_____	ILLUM

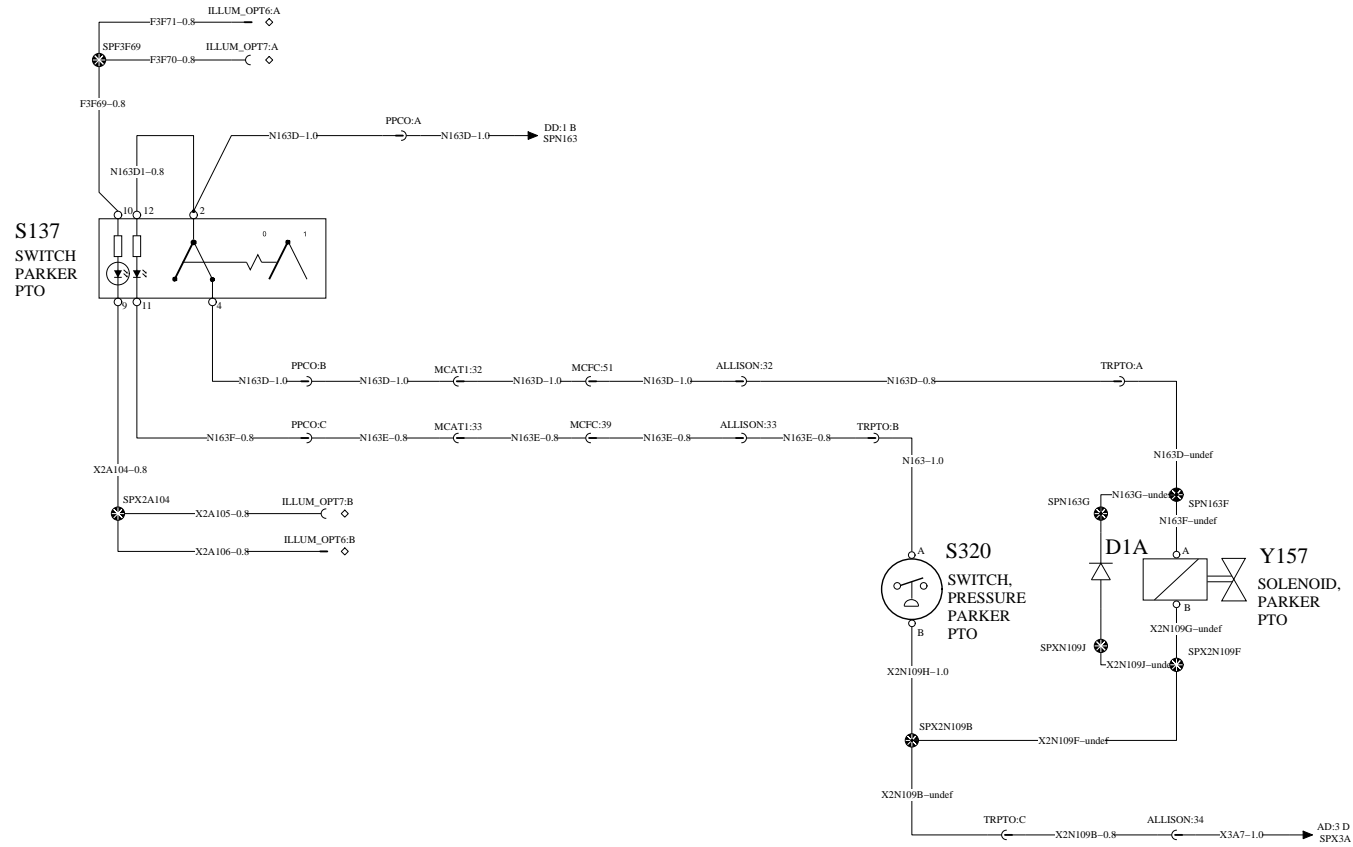

MACK

Mack Trucks Inc.

Document title
WIRING DIAGRAM

Document type
PRODUCT SCHEMATIC

Drawing No.

22525262

Revision

02

Page

29 (45)

LIGHTING CONTROL

WIRING DIAGRAM: GA - O

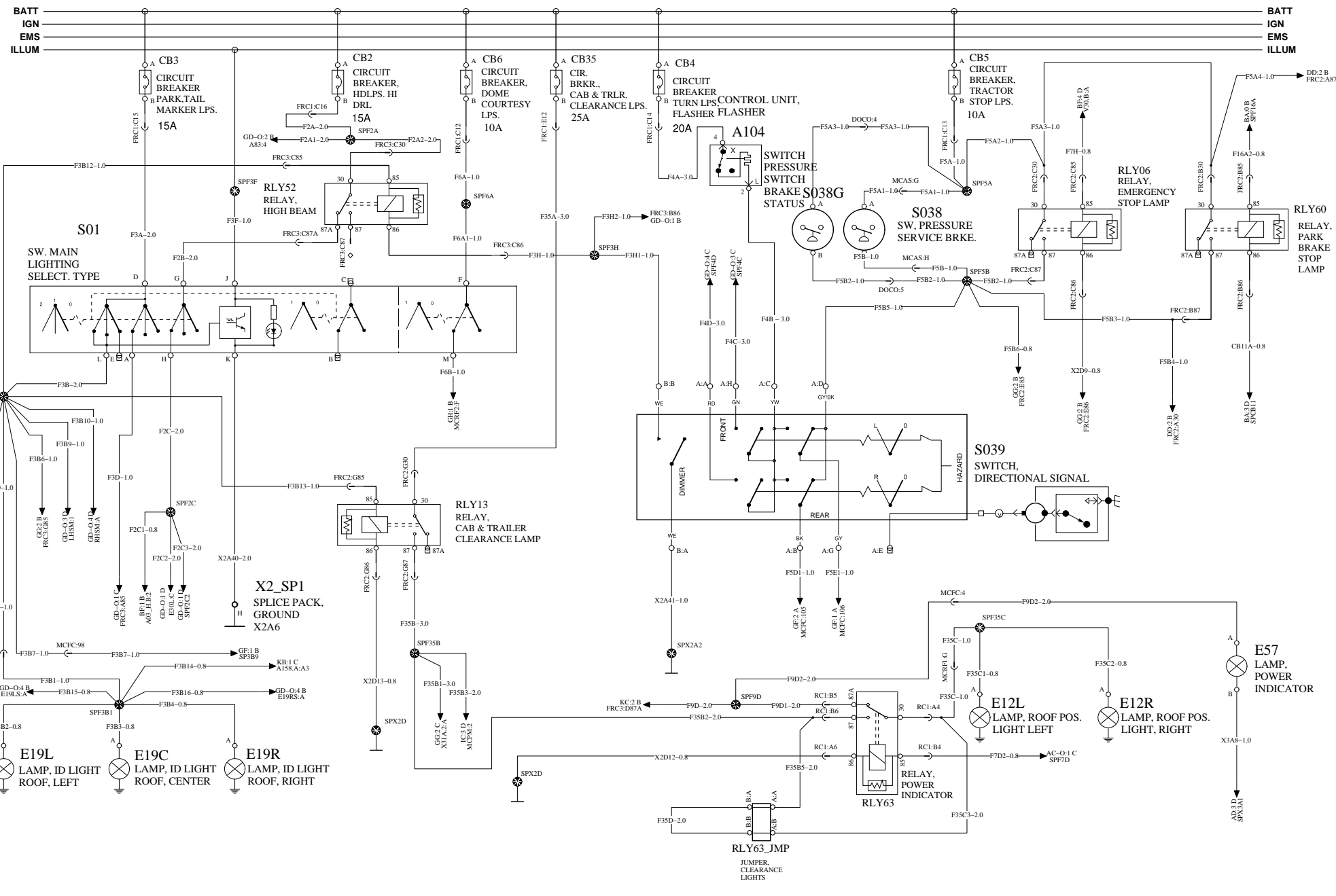

MACK

Mack Trucks Inc.

Document title
WIRING DIAGRAM
Document type
PRODUCT SCHEMATIC

Drawing No.
22525262

Revision
02

Page
30 (45)

0

1

2

3

4

TRAILER LIGHTING CONTROL

WIRING DIAGRAM: GG

BATT
IGN
EMS
ILLUM

BATT
IGN
EMS
ILLUM

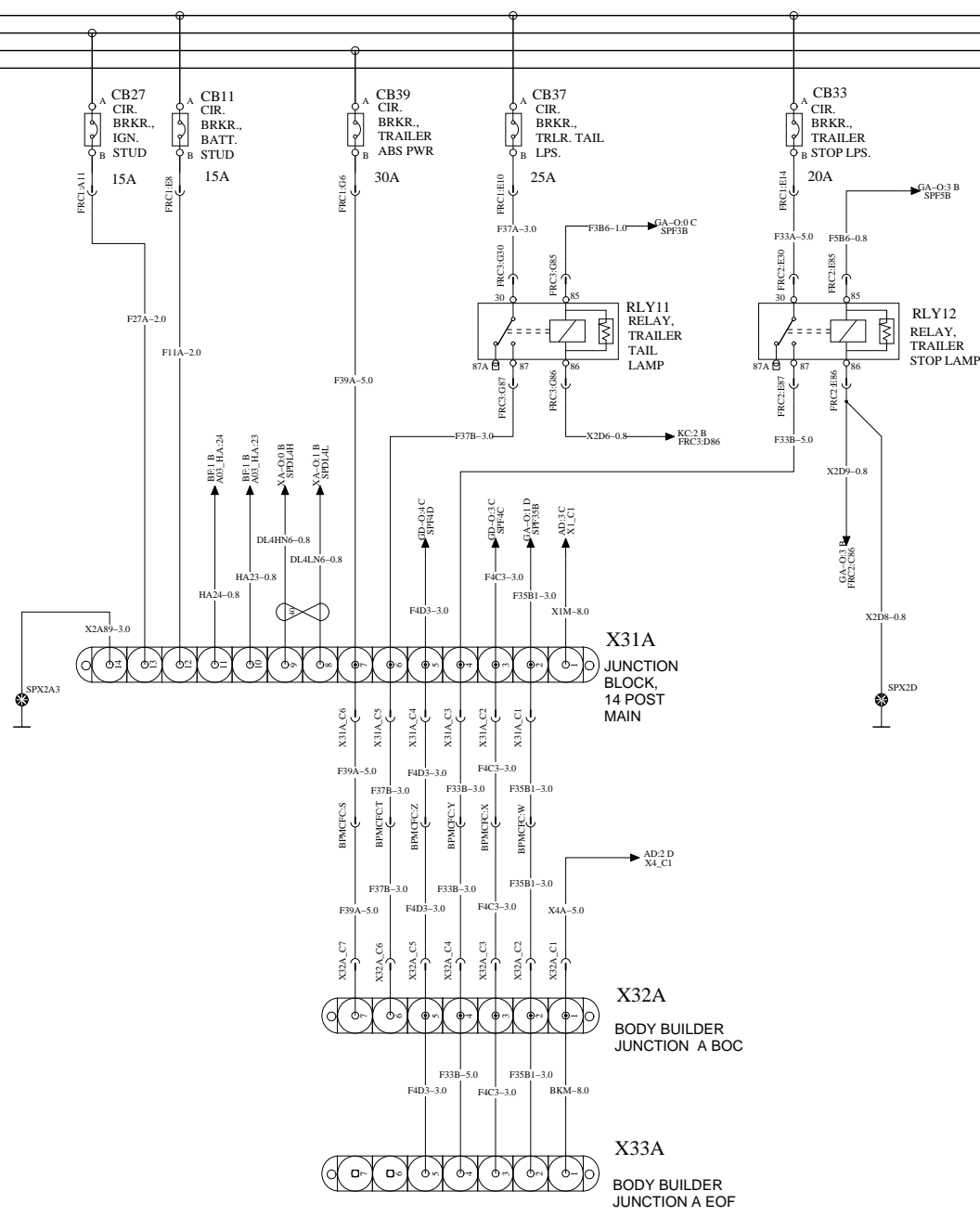

MACK

Mack Trucks Inc.

Document title WIRING DIAGRAM	Drawing No. 22525262	Revision 02	Page 33 (45)
Document type PRODUCT SCHEMATIC			

0

1

2

3

4

WIPER/WASHER

WIRING DIAGRAM: GP

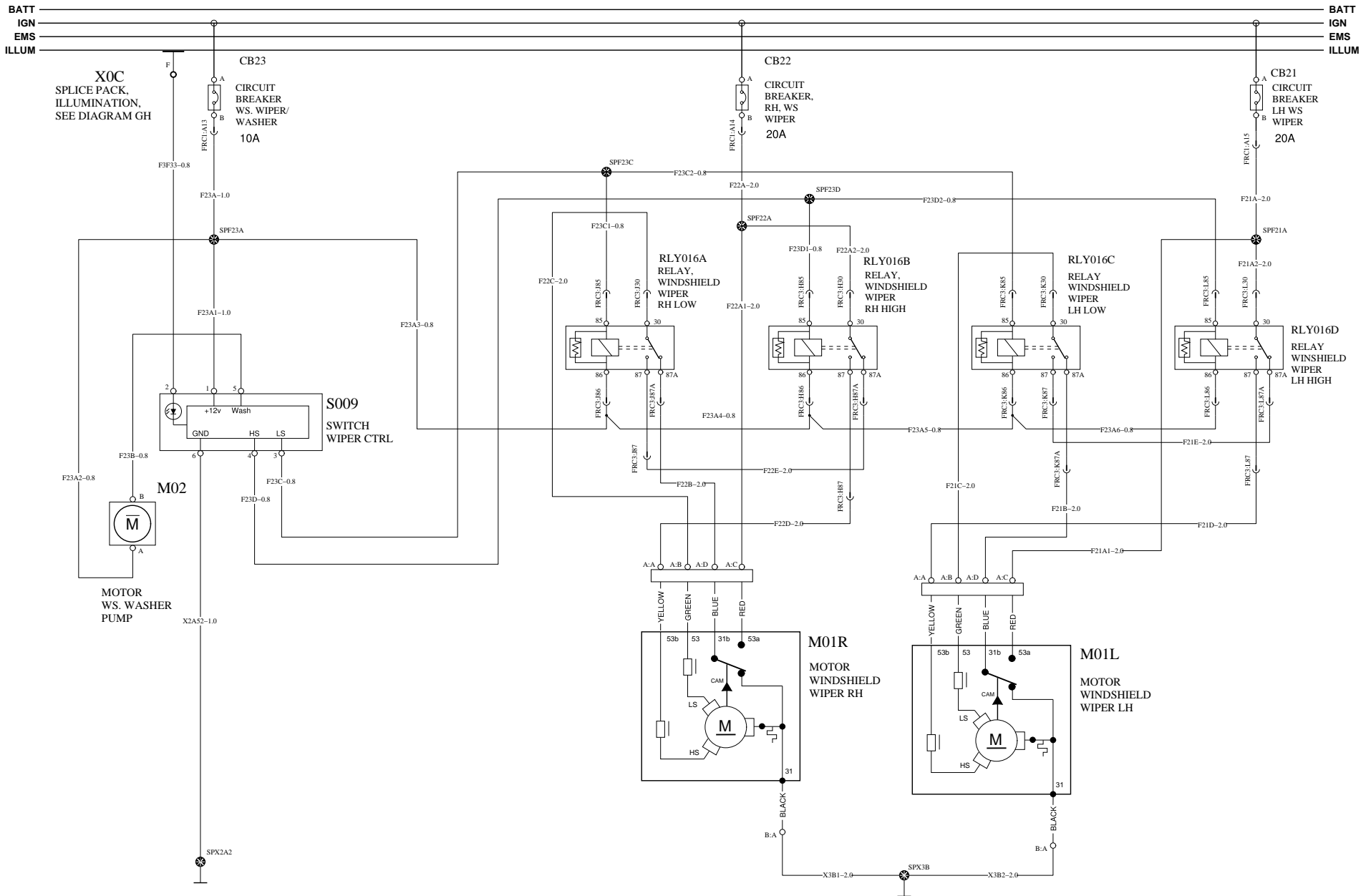

MACK

Mack Trucks Inc.

Document title
WIRING DIAGRAM
Document type
PRODUCT SCHEMATIC

Drawing No.
22525262

Revision
02

Page
35 (45)

HORN WIRING

WIRING DIAGRAM: GQ

BATT
IGN
EMS
ILLUM

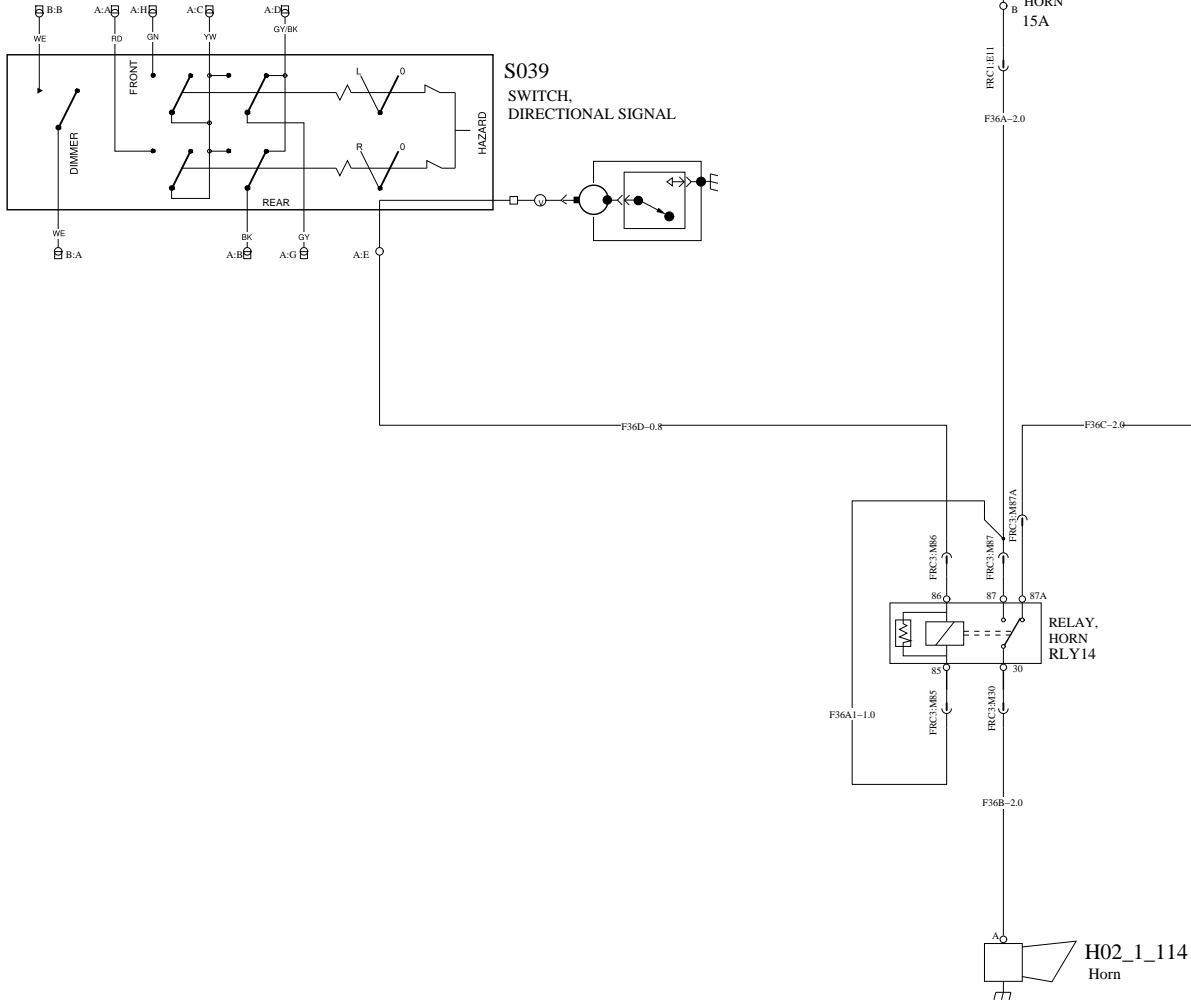

MACK	Mack Trucks Inc.	Document title WIRING DIAGRAM	Drawing No. 22525262	Revision 02	Page 36 (45)
		Document type PRODUCT SCHEMATIC			

MIRROR CONTROL 1/2

WIRING DIAGRAM: IC

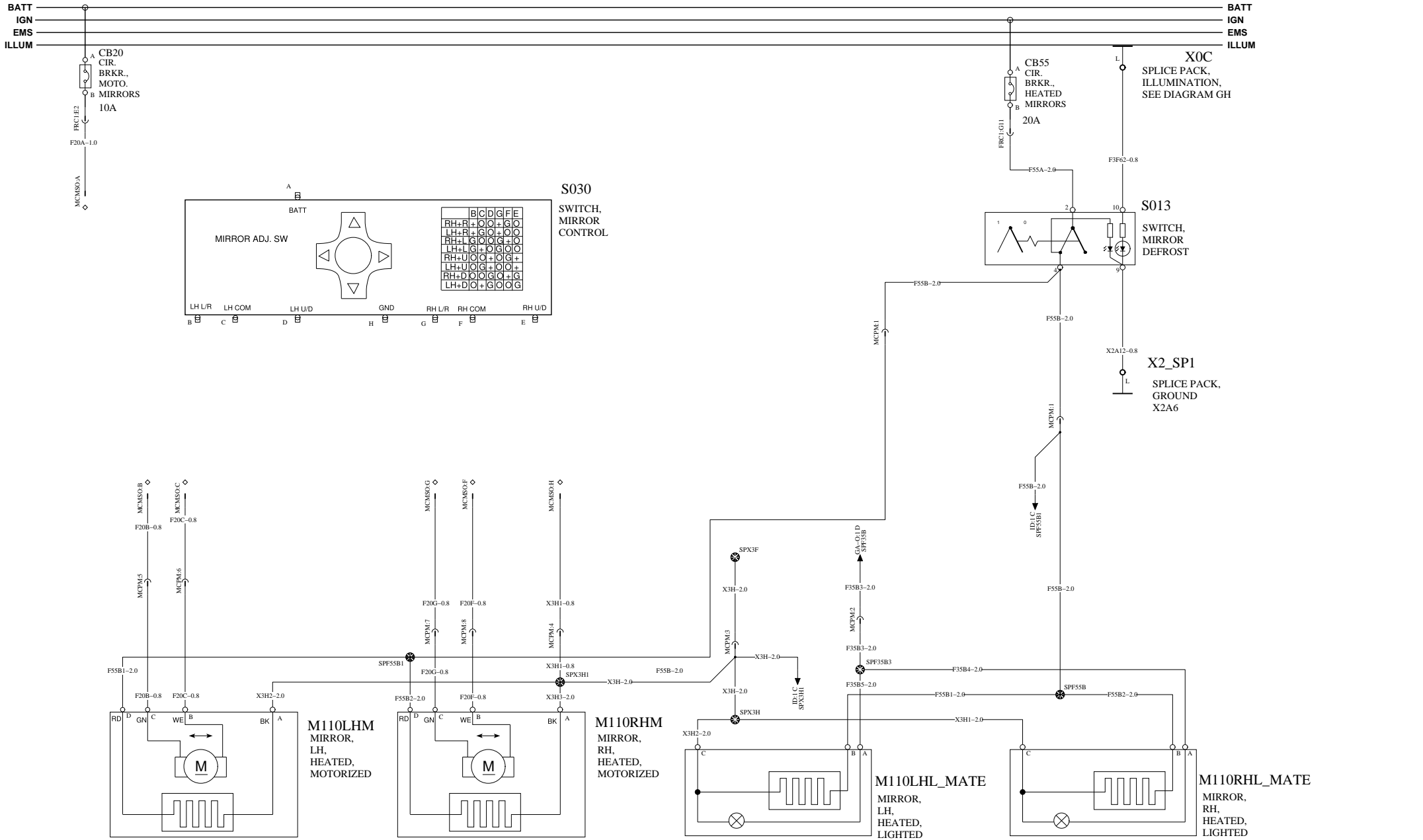

HEATED & MOTORIZED MIRRORS

HEATED & LIGHTED MIRRORS

MACK

Mack Trucks Inc.

Document title
WIRING DIAGRAM

Document type
PRODUCT SCHEMATIC

Drawing No.
22525262

Revision
02

Page
38 (45)

MIRROR CONTROL 2/2

WIRING DIAGRAM: ID

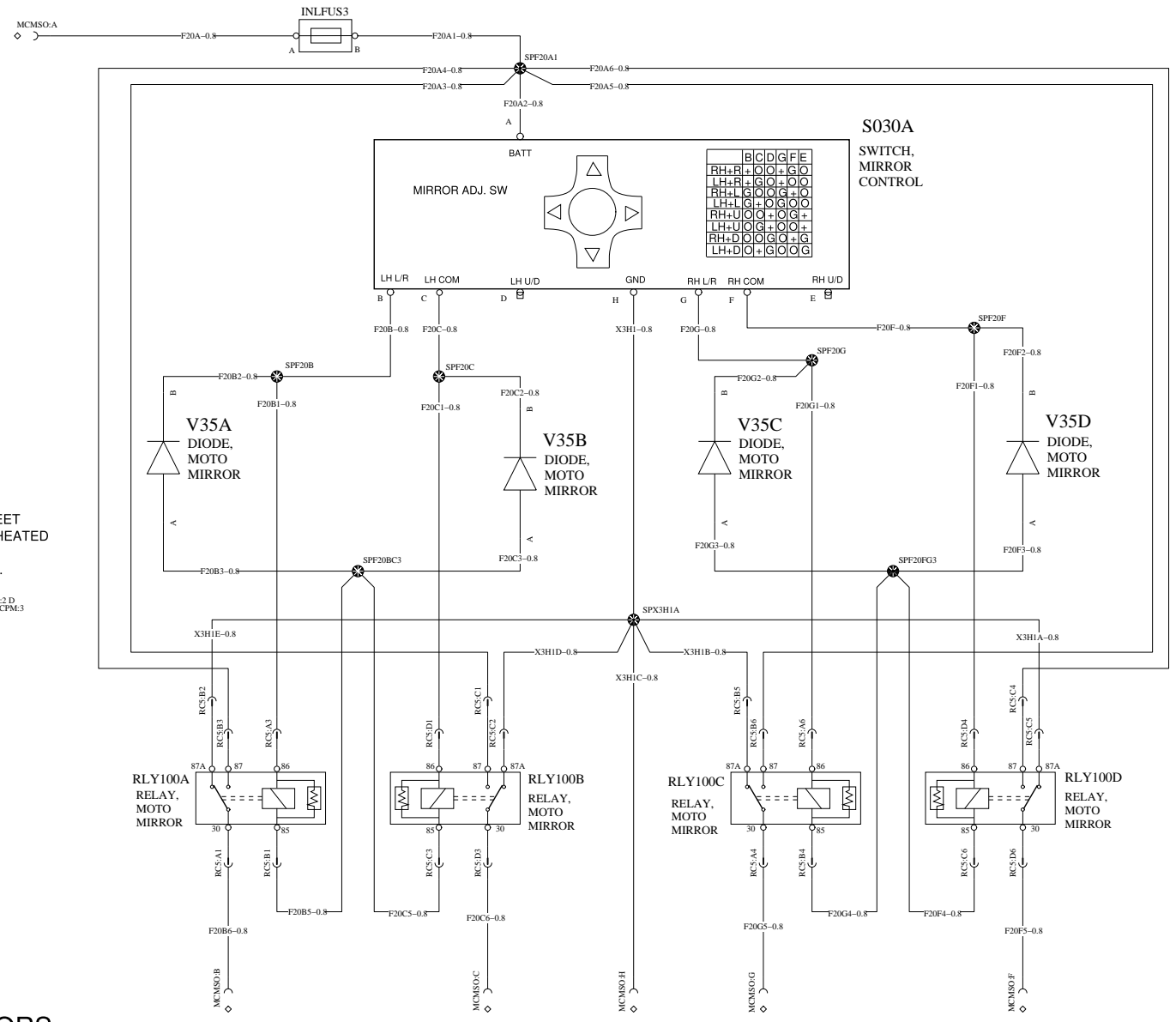
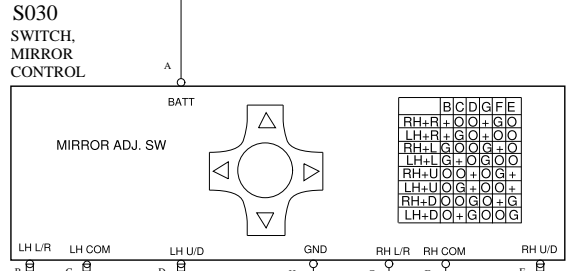
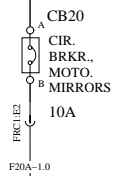
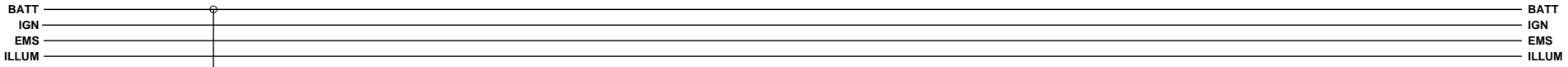

SEE SHEET IC FOR HEATED MIRROR CIRCUIT.

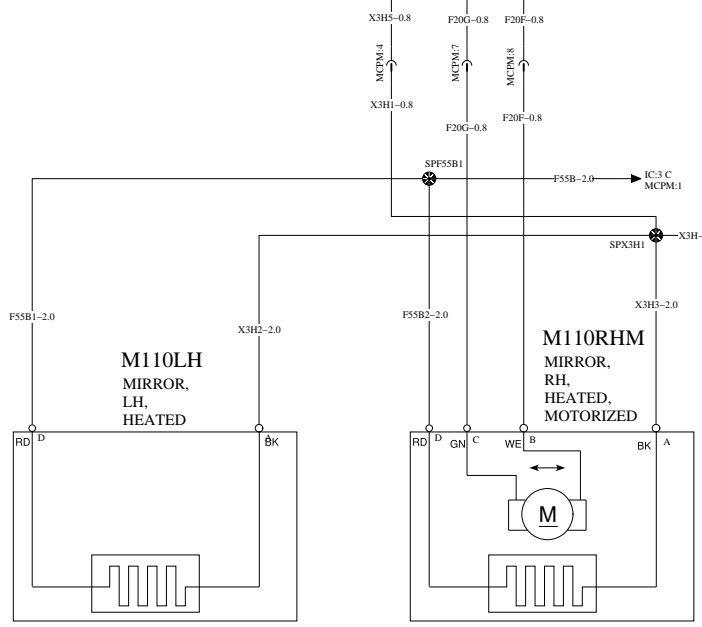

LH HEATED & RH HEATED AND MOTORIZED MIRRORS

VISUAL SYSTEMS

WIRING DIAGRAM: KA

BATT
IGN
EMS
ILLUM

BATT
IGN
EMS
ILLUM

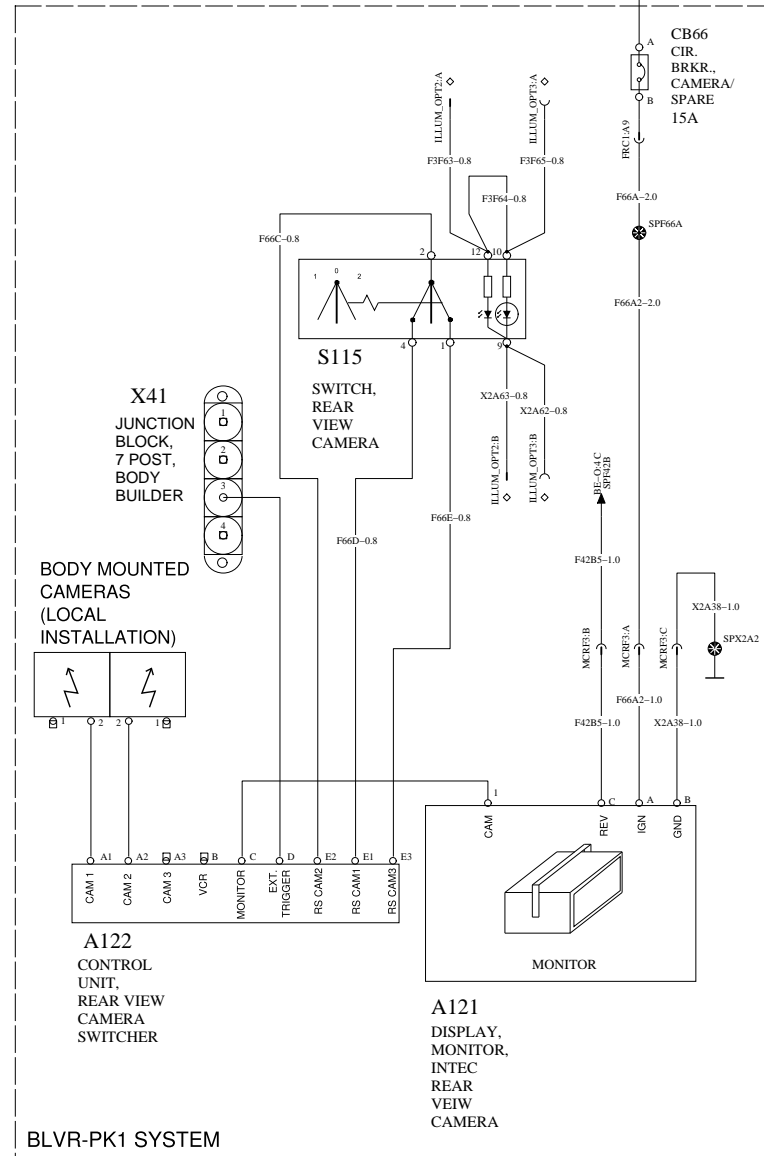

MACK

Mack Trucks Inc.

Document title
WIRING DIAGRAM

Document type
PRODUCT SCHEMATIC

Drawing No.
22525262

Revision
02

Page
40 (45)

AUDIO SYSTEMS

: KB

BATT
IGN
EMS
ILLUM

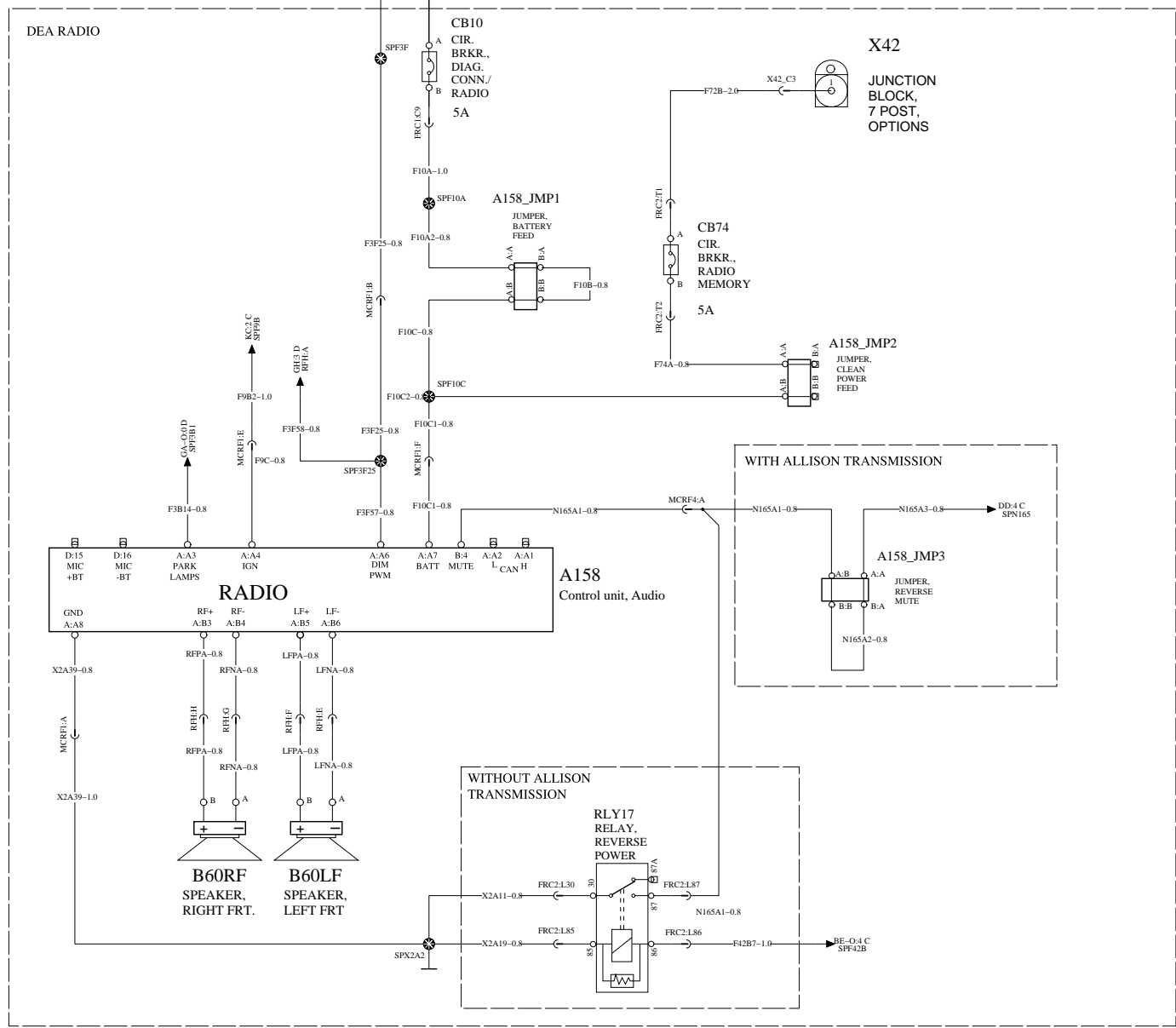

MACK

Mack Trucks Inc.

Document title
WIRING DIAGRAM

Document type
PRODUCT SCHEMATIC

Drawing No.
22525262

Revision
02

Page
41 (45)

POWER OUTLET CONNECTIONS

WIRING DIAGRAM: KC

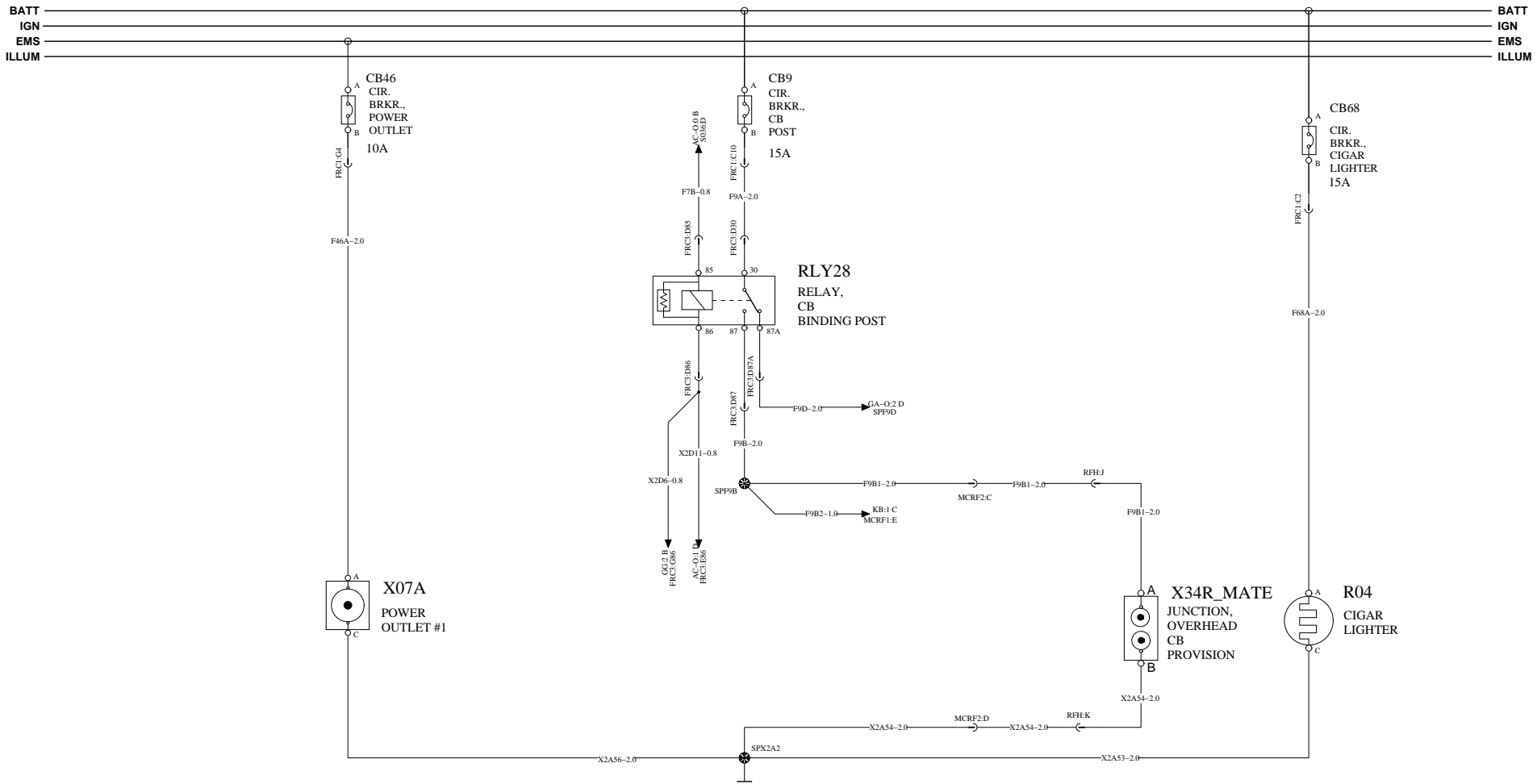

MACK

Mack Trucks Inc.

Document title
WIRING DIAGRAM

Document type
PRODUCT SCHEMATIC

Drawing No.
22525262

Revision
02

Page
42 (45)

JUNCTION POSTS

WIRING DIAGRAM: NB - O

BATT
IGN
EMS
ILLUM

BATT
IGN
EMS
ILLUM

A

A

B

B

C

C

D

D

E

E

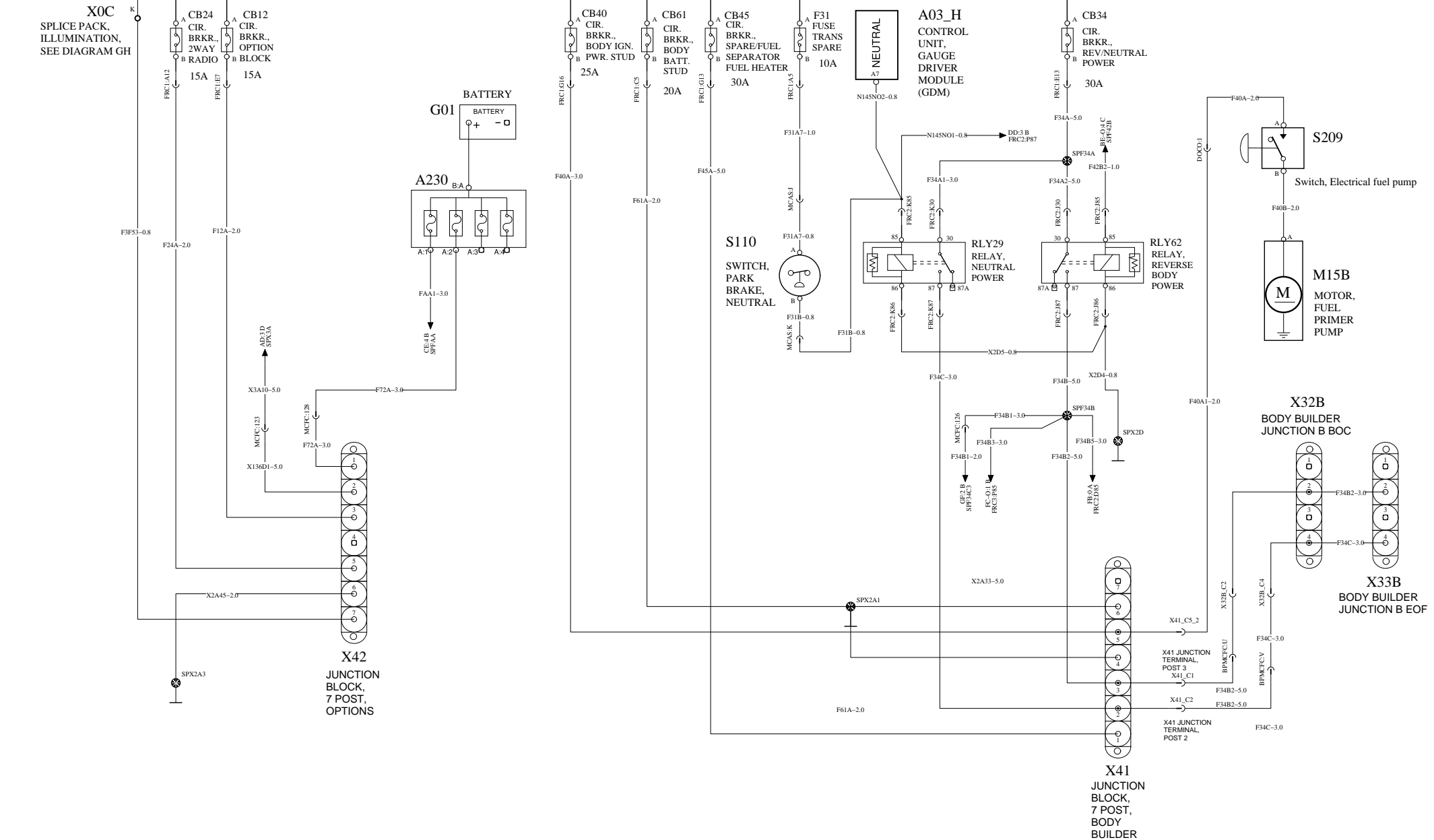

MACK

Mack Trucks Inc.

Document title
WIRING DIAGRAM
Document type
PRODUCT SCHEMATIC

Drawing No. 22525262	Revision 02	Page 44 (45)
--------------------------------	-----------------------	------------------------

