

# BODY BUILDER INSTRUCTIONS

Mack Trucks



Axle and Suspension  
MD  
Section 6

## Introduction

This information provides design and function, specification and procedure details for axles and suspension for MACK vehicles.

**Note:** We have attempted to cover as much information as possible. However, this information does not cover all the unique variations that a vehicle chassis may present. Note that illustrations are typical but may not reflect all the variations of assembly.

All data provided is based on information that was current at time of release. However, **this information is subject to change without notice.**

Please note that no part of this information may be reproduced, stored, or transmitted by any means without the express written permission of MACK Trucks, Inc.

## Contents:

- “Clearance Rear Wheels and Axles”, page 3
- “Axle Alignment”, page 4
- “Rear Axle Literature”, page 10
- “Rear Suspension”, page 11
- “U-Bolt Torque”, page 14
- “Ride Height and Pinion Angle Specifications”, page 15

# Axle and Suspension

## Special Tools

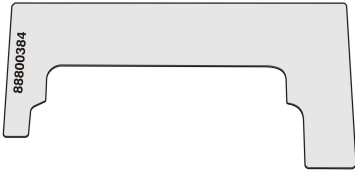

T0070273

**88800384**  
Ride Height Gauge



W0001815

**J-44544**  
Ride Height Adjustment Socket

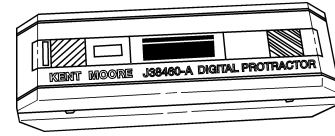

W7000708

**J-38460-A**  
Digital Protractor, Includes **J-38460-25**  
Quick Disconnect Adapter

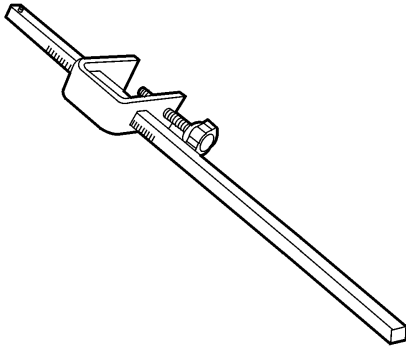

W0001960

**J-44684** Ride Height Gauge

# Clearance Rear Wheels and Axles

Sufficient clearance must be maintained to allow full vertical movement of the rear axles and tires as the vehicle travels over rough terrain or uneven surfaces.

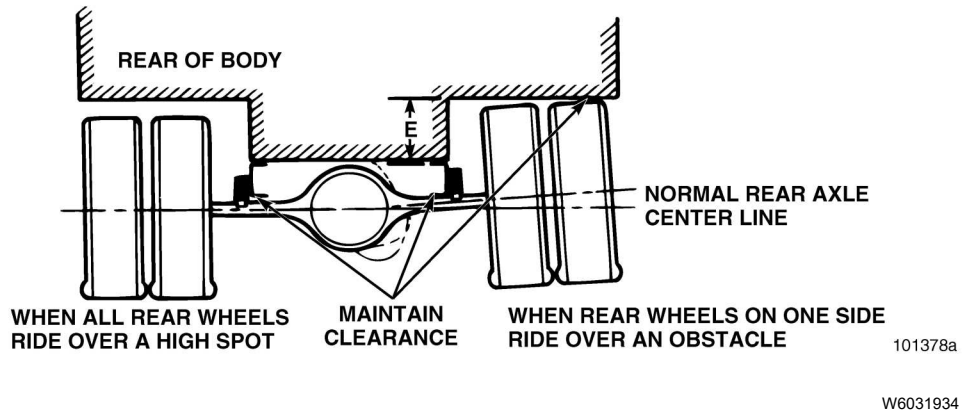

Allow Clearance for Vertical Movement of Rear Axles and Tires

## Notes

---

---

---

---

---

# Axle Alignment

The following specifications are being furnished to inform the field of the latest MACK axle alignment specifications.

## Caster

The rearward or forward tilt of the steer axle kingpin, in reference to the vertical plane, is measured in degrees. Caster is positive when the steering axis is tilted rearward and is negative when the tilt is forward.

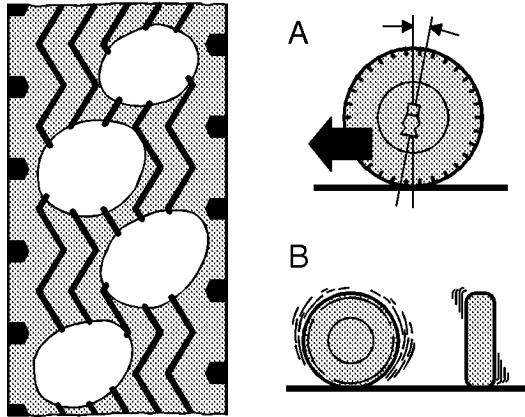

T1006460

- A. Caster Angle
- B. Imbalance

All measurements must be taken with the vehicle in an unloaded condition, and the steering axle and drive axle(s) on a level surface.

Right hand and left hand caster readings should not vary by more than 0.5° (1 mm/m) from side to side (cross caster). Do not bend the axle or otherwise try to adjust the caster angle. Caster shims may be used to correct caster.

<b>Caster Specifications</b>	$4 \pm 1^\circ$
------------------------------	-----------------

### Notes

---



---



---



---



---

# Wheel Camber

The angle formed by the inward or outward tilt of the wheel referenced to the vertical plane. Camber is positive when the wheel is tilted outward at the top and is negative when the wheel is tilted inward at the top.

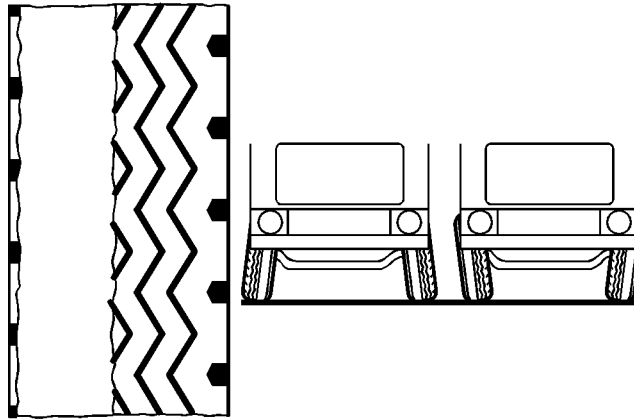

T1006458

Tire Wear Due to Incorrect Camber

<b>Camber Specifications</b>	$0.25 \pm 0.43^\circ$
------------------------------	-----------------------

Loading the axle will cause the camber to decrease. Right hand and Left hand camber readings should not vary by more than  $0.5^\circ$  from side to side (cross camber). Do not bend the axle or otherwise try to adjust the camber angle. If the camber angle is found to be out of specification, notify the axle manufacturer.

## Straight Forward Position

The thrust angle of the left hand road wheel is set to the 1st drive axle and must be  $0^\circ \pm 0.02^\circ$ . This is the straight ahead position and prepares the vehicle for wheel toe measurement.

## King Pin Inclination

<b>King Pin Inclination</b>	$6.5^\circ$
-----------------------------	-------------

### Notes

---



---



---



---



---

## Toe Angle

Toe angle is the angle of the horizontal lines drawn through the wheels of the same axle. The angle can also be measured at the tire's front and rear tread center at a distance above the ground equal to the tire's rolling radius.

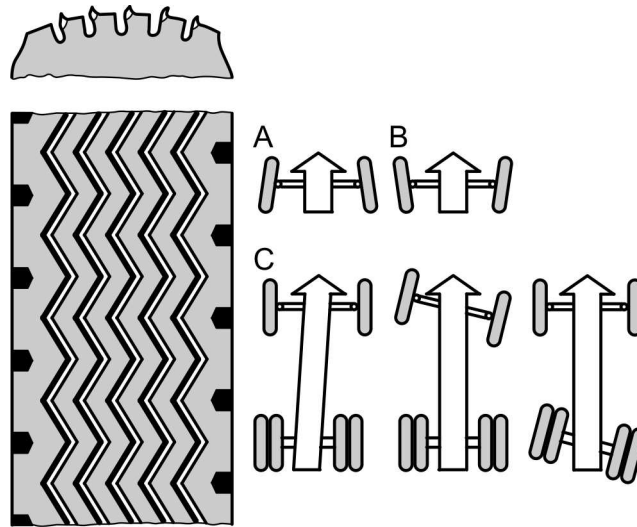

W1079988

Toe Angle / Thrust Angle

- A. Toe-in
- B. Toe-out
- C. Out-of-line axle

To adjust the toe-in, ensure that the vehicle is in unloaded condition. Toe should be checked at the tire's front and rear tread center at a distance above the ground equal to the tire's rolling radius. It may also be checked with equipment that senses the difference between left and right hand thrust angles.

When adjusting toe, ensure that the tensioning bolt is in the vertical position and behind the tie rod. Improper orientation could result in a loss of adjustment.

Toe Specifications	
Total Toe-In (Chassis without load)	1.5± 0.75 mm/m
Right Wheel Toe-In (Chassis without load)	0.75± 0.375 mm/m
Left Wheel Toe-In (Chassis without load)	0.75± 0.375 mm/m

## Axle Perpendicularity (Thrust Angle) Requirement

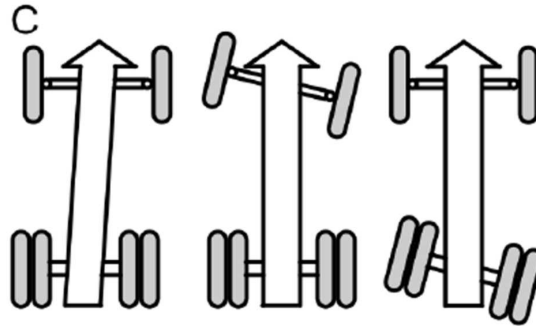

W6114032

C. Out of line axle

Suspension	mm (in.)	deg
MACK AI170/AL190	1.4 mm (0.55)	±0.04
Hendrickson	2.8 mm (0.11)	±0.08

**Note:** For suspensions not documented in the above table, refer to the manufacturer's instructions.

### Bogie Wheelbase

Bogie wheelbase side-to-side variation of 3.3 mm (1/8") is to be held on MACK taperleaf suspensions — AL190 and AL170, spring suspensions.

A tolerance of 6.4 mm (1/4") bogie wheelbase side-to-side variation is to be held on all MACK SS/SW suspensions with camelback springs or walking beams equipped with rubber shock insulators. This tolerance also includes Hendrickson suspensions.



#### CAUTION

Bogie wheelbase variation may be caused by a broken spring leaf. Prior to proceeding, VERY CAREFULLY inspect all spring leaves to ensure that NONE are cracked or broken. Be especially careful to inspect behind the spring clips (U-bolts). Rust streaks originating from this area are an indicator of broken spring leaves. Also, wear at the shock insulator caps in the T-slot area would be a sign of broken leaves. If a cracked or broken leaf is found, replace the spring assembly before making any additional measurements.

## Chassis Wheelbase

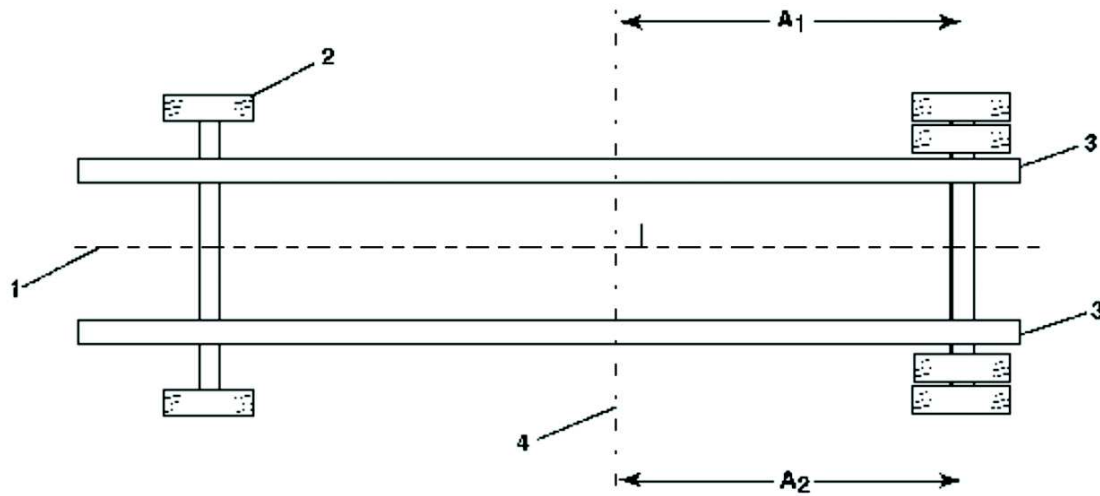

**Figure 5 — 4 x 2 Chassis —  $A_1 = A_2$  with a Tolerance of No More Than 1/8 Inch (3.3 MM)**

1. Chassis Centerline	3. Frame Rail
2. Front Axle	4. Perpendicular Datum

W6114033

### Tolerance Bands for Scrub Angle

Suspension	mm (in)	deg
Mack AL170/AL190	1.4 mm (0.55)	$\pm 0.04$
Hendrickson	2.8 mm (0.11)	$\pm 0.08$

**Note:** For suspensions not documented in the above table, refer to the manufacturer's instructions.

### Axle Alignment

The following specifications have been established for axle alignment on a MACK vehicle under chassis only conditions in order to achieve the optimum in tire wear and subsequent customer satisfaction. Before taking measurements, always drive the vehicle back and forth in a straight line four or five times. Where distance is limited, at least the length of the chassis should be traveled. This operation must be performed to ensure that the suspension has not taken a set.

**Notes**

---



---



---



---



---



## Centering Rear Axles (Chassis Equipped with SS Suspensions)

To center rear axles equipped with SS suspensions, a measurement must be made between the frame and the brake drums on each axle. A convenient extension straightedge can be made from a straight piece of steel bar stock and attached to the frame rail with magnets. With a tape measure, measure from the straightedge to the brake drum at the three designated points shown in the illustration below.

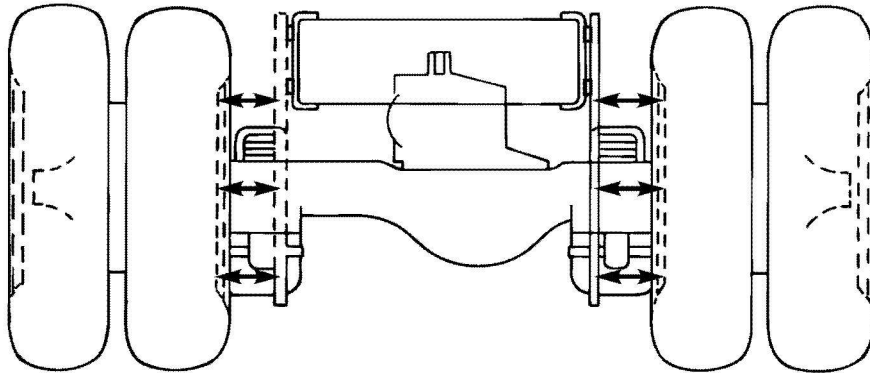

W6078915

The maximum allowable difference between the measurements taken at the front-rear and rear-rear brake drums to the straightedge must not exceed 1/4 in (6.4 mm), whether the chassis is equipped with a transverse torque rod.

The maximum allowable difference between the left- and right-hand sides on the same axle, front-rear or rear-rear must not exceed 1/4 in (6.4 mm) if the chassis is equipped with a transverse torque rod, or 12.7 mm (1/2 in) if the chassis is NOT equipped with a transverse torque rod.

## Centering Rear Axles (Chassis Equipped with AL Suspension and Fixed-Length Transverse Torque Rods)

The first step in proper axle alignment is verifying that the rear axles are properly centered on the chassis. Before any alignment measurements are taken, the chassis should be driven back and forth in a straight line several times to allow the suspension to move into its normal operating position. To verify that the rear axles are centered, perform the following steps:

- 1 With the chassis parked on a level surface, block the front wheels to prevent the vehicle from moving, then release the parking brakes. (Air system pressure should be between 110 to 130 psi when performing these procedures.)
- 2 Measure the ride height. Ride height gauges are available to accurately measure chassis ride height. Refer to Ride Height for information on using the gauges and measuring ride height.
- 3 After the ride height has been checked and/or adjusted, determine if the axles are centered by measuring from the outside of the frame rail to the inside edge of the spring clip (U-bolt) (Dimension "A" in the illustration below). The maximum allowable side-to-side difference on any one axle is 6.34 mm (1/4 in). Washer spacers can be added or removed from either side of the torque rod in order to obtain the correct axle positioning.
- 4 After axle centering is verified or corrected, exhaust the air from the suspension and verify that no interference exists between the frame rail and any spring clip (U-bolt).

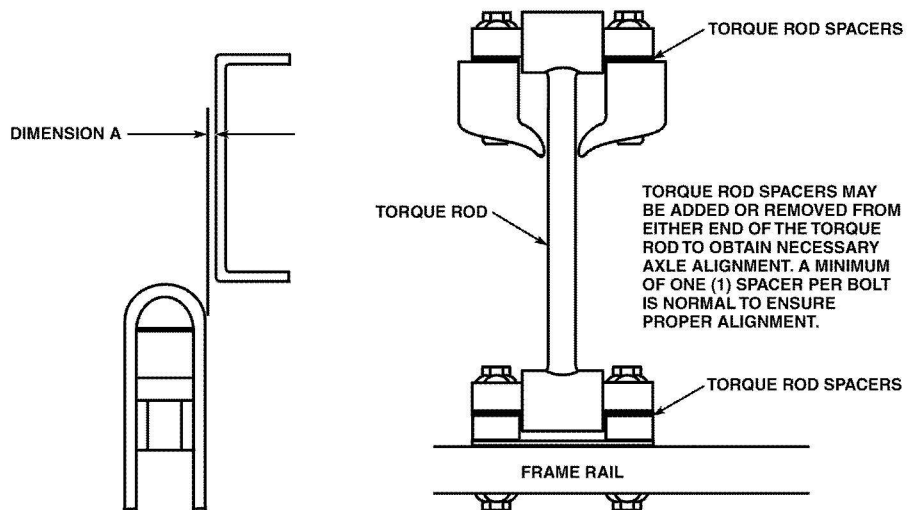

W6078909

## Rear Axle Literature

Printed copies of the rear axle literature are no longer available from the axle suppliers. Therefore, MACK is unable to supply this printed literature to its dealers.

Service manuals for many of the supplier's rear axles are now available from the official web sites Dana Corporation and Meritor.

To review and download rear axle literature, please visit:

<http://www.dana.com>

<http://www.meritor.com/customer/northamerica/lod/default.aspx>

# Rear Suspension

The following section details the various suspensions. Included is design and function, specification and procedure information.

**Note:** HENDRICKSON, PRIMAAAX and QUIK-ALIGN are either registered trademarks or trademarks of (i) Hendrickson USA, L. L.C. in the United States, and (ii) Hendrickson International Corporation outside the United States.

## Alignment and Adjustments

### Lateral Alignment

- 1 Use a work bay with a level floor. Drive the vehicle slowly, straight ahead. Try to slacken or loosen the suspension as the vehicle is positioned. End with all wheels positioned straight ahead. Try to roll to a stop without the brakes being used. Do not set the parking brake. Chock the front wheels of the vehicle.
- 2 Measure from the outside of the frame rail to the rim flange of the inner tire. Record the measurement.
- 3 Measure the same distance on the opposite side of the same axle. Record the measurement.
- 4 Subtract the two measurements to get a difference between the two. If the difference is greater than 1/8 in.(3 mm) it will be necessary to correct the lateral alignment. Adding or removing shims that are located between the transverse torque rod and frame rail accomplishes this. A general rule of thumb is to use a shim with a thickness that is half of the difference between the two measurements.

The mounting fasteners used with the straddle mount transverse torque rods are furnished by the vehicle manufacturer. It is important to check the locknuts for proper torque during preventive maintenance service intervals. Follow the vehicle manufacturer's specifications for tightening torque values. All torque rods must be inspected for looseness by one of the following methods:

- **Method 1:** For Tractor applications only with brakes applied, slowly rock the empty vehicle with power while a mechanic visually checks the action at both ends.
- **Method 2:** With the vehicle shut down, a lever check can be made with a long pry bar placed under each rod end and pressure applied.

Visually inspect torque rod bushings for torn or shredded rubber, for bent, cracked, or broken torque rods, and also for end hubs that have an elongated "oval" shape. Any of these conditions require component replacement. Rod ends can be renewed by pressing out the worn bushing, and installing a replacement bushing. In the event of structural damage, the entire torque rod assembly should be replaced. The torque rods are made to a specified length or a two-piece transverse torque rod can be cut and welded to the desired length (if available).

**Note:** Hendrickson recommends the use of Grade 8 bolts and Grade C locknuts be used for all torque rod attachments.

# Axle Pinion Angle

Drive axle pinion angles are established by the vehicle manufacturer. The suspension axle brackets called out are machined to specific angles to meet the vehicle manufacturer specified requirements. If it is necessary to fine tune the pinion angle, first verify that the suspension is at the proper ride height. Install a digital protractor on the axle housing. Check that the pinion angle is within the specified range.

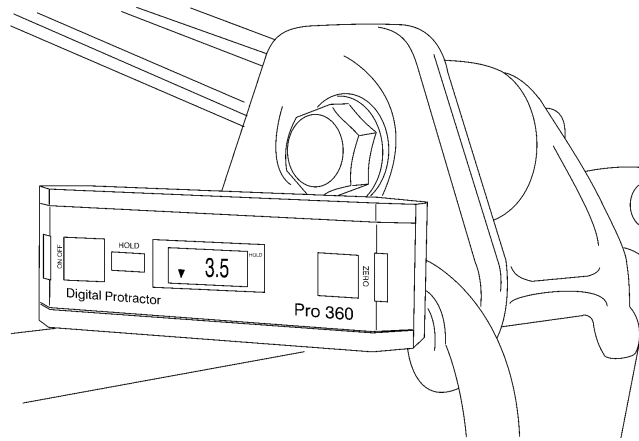

W7001406

Fig. 1 Digital Protractor J-38460-A

## Notes

---

---

---

---

---

---

# Rear Axle Alignment Inspection

Proper alignment is essential for maximum ride quality, performance and tire service life. The recommended alignment procedure is described below. This procedure should be performed if excessive or irregular tire wear is observed, or anytime the QUIK-ALIGN connection is loosened or removed.

- 1 Use a work bay with a level floor. Drive the vehicle slowly, straight ahead. Try to slacken or loosen the suspension as the vehicle is positioned. End with all wheels positioned straight ahead. Try to roll to a stop without the brakes being used.
- 2 Chock the front wheels of the vehicle. Do not set the parking brake.
- 3 Verify that the proper ride height is set.
- 4 If axle alignment equipment is not available, using "C" clamps, securely clamp a six-foot piece of STRAIGHT bar stock or angle iron across the lower frame flange. Select a location for the angle iron as far forward of the drive axle as possible, where components will not interfere.
- 5 Accurately square the straight edge to the frame using a carpenter's square.
- 6 Using a measuring tape, measure from the straight edge to the forward face of the drive axle arms at the centerline on both sides of the vehicle, **A** and **B**. If both sides measure within the vehicle manufacturer's specifications, alignment of the drive axle is acceptable.

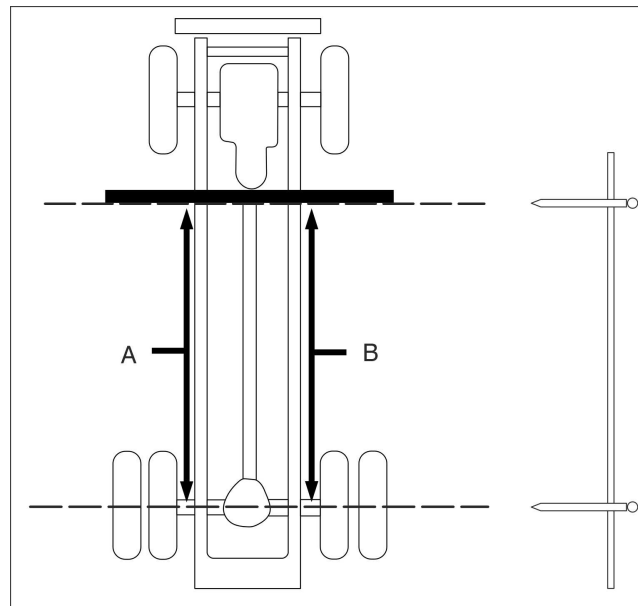

T6163285

Fig. 2 Front drive axle alignment

# U-Bolt Torque

## Leaf Spring Suspension

Tighten the U-Bolt locknuts evenly and torque the nuts in a proper sequence.

U-Bolt tightening torque value is  $460 \pm 23$  Nm ( $338.24 \pm 16.90$  ft-lb).

U-bolt protrusion length is 0 – 5 mm (0 – 0.2 in) (ensure that a minimum of two threads are visible).

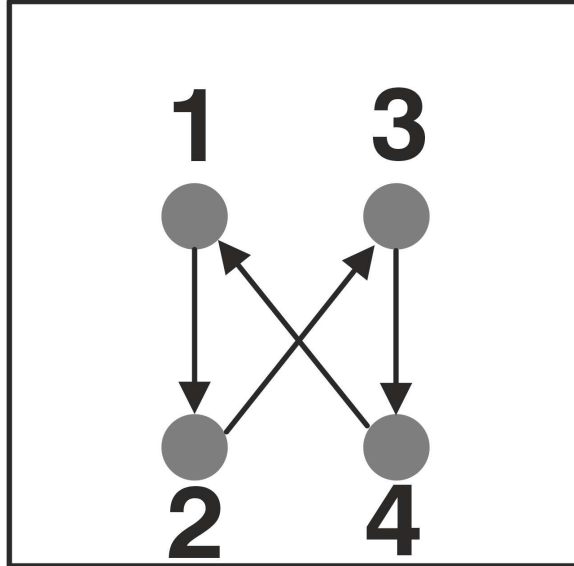

T7191693

Torquing Sequence

## Air Leaf Suspension

Tightening torque of U-Bolt, nut M22 is  $575 \pm 50$  Nm ( $424 \pm 37$  ft-lb)

**Note:** Tighten the U-Bolt nut diagonally.

## Notes

---

---

---

---

---

# Ride Height and Pinion Angle Specifications

## Ride Height for Air Leaf Suspension

The ride height (A) is measured from the centre of the first drive axle hub to the bottom of the frame.

Ride height (A) is 210 mm (8.27 in).

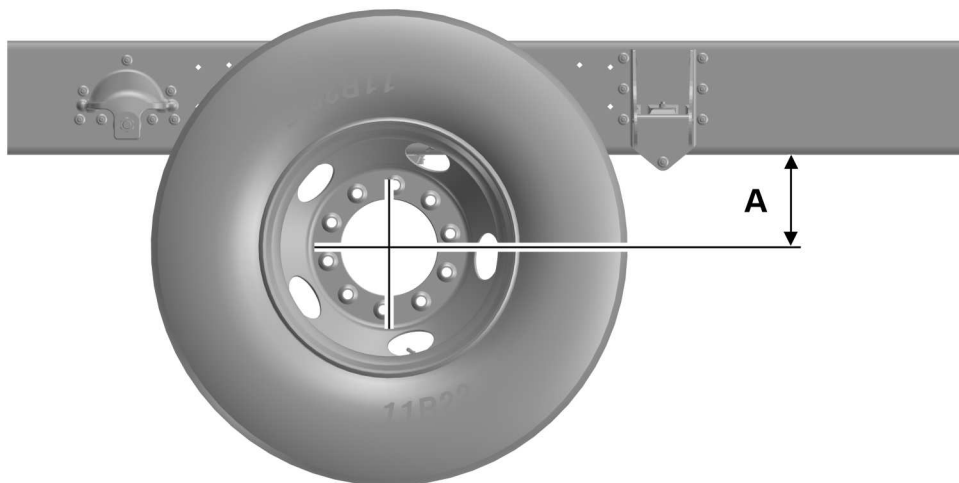

T7191692

**Note:** HENDRICKSON, PRIMAX and QUIK-ALIGN are either registered trademarks or trademarks of (i) Hendrickson USA, L.L.C. in the United States, and (ii) Hendrickson International Corporation outside the United States.

**Note:** Use only Genuine Hendrickson parts for servicing this suspension system.

This information covers specifications for ride height and pinion angle, including suspension applications and torque specifications.

## Suspension Applications

Suspension Configuration	Maximum GAWR Metric Ton (lb)	Axle Spacing mm (in.)	Required Number of Parking Chambers	Available Axles	
				Models	Metric Ton (lb)
4x2	12.99(25,995)	N/A	TWO	Meritor	10.5 (21,000)

(1) GCW (Gross Combination Weight) rating can be reduced by vehicle operating applications, engine horsepower/torque, axle type/model, axle ratio, and/or vehicle tire size.

### Notes

---



---



---



---



---



# Pinion Angle Specifications

Rear Axle	Rear Axle Position	Part no	Pinion Angle (°)
RS1045SM	RAP6440	78568122	7 ± 0.3°
	RAP7350	78568121	5.5 ± 0.3°
	RAP6840		
	RAP7860	78568120	3.75 ± 0.3°
	RAP8240		
	RAP8620		
	RAP9000		
	RAP9485		
RSS0819B	RAP6440	78568122	7 ± 0.3°
	RAP7350	78568121	5.5 ± 0.3°
	RAP6840		
	RAP7860	78568120	3.75 ± 0.3°
	RAP8240		
	RAP8620		
	RAP9000		
	RAP9485		
RSS0919A	RAP6440	78568122	7 ± 0.3°
	RAP7350	78568121	5.5 ± 0.3°
	RAP6840		
	RAP7860	78568120	3.75 ± 0.3°
	RAP8240		
	RAP8620		
	RAP9000		
	RAP9485		
RSS1019A	RAP6440	78568122	7 ± 0.3°
	RAP7350	78568121	5.5 ± 0.3°
	RAP6840		
	RAP7860	78568120	3.75 ± 0.3°
	RAP8240		
	RAP8620		
	RAP9000		
	RAP9485		

**Air leaf suspension**

Rear Axle	Rear Axle Position	Part no	Pinion Angle (°) Spring Suspension	Pinion Angle (°) Air Suspension
RSS0819B/ RSS0919A/ RSS1019A	RAP6440	78568122	7 ± 0.3°	4.5 ± 0.3°
	RAP7350	78568121	5.5 ± 0.3°	3.1 ± 0.3°
	RAP6840			
	RAP7860	78568120	3.75 ± 0.3°	1.5 ± 0.3°
	RAP8240			
	RAP8620			
	RAP9000			
	RAP9485			